



UNIVERSITI PUTRA MALAYSIA

***DETECTION OF COPPER ION USING AD5933 EVALUATION BOARD
WITH INTERDIGITATED ELECTRODE (IDE)***

AMZAR KHALILI BIN KHALID

**Ip
FS 2022 14**



**DETECTION OF COPPER ION USING AD5933 EVALUATION BOARD WITH
INTERDIGITATED ELECTRODE (IDE)**

By

AMZAR KHALILI BIN KHALID

**Thesis Submitted to the Department of Physics, Universiti Putra Malaysia, in
partial Fulfilment of the Requirements for the Degree of Bachelor of Science**

Physics (Honours)

FEBRUARY 2022

All material contained within the thesis, including without limitation text, logos, icons, photographs and all other artwork, is copyright material of Universiti Putra Malaysia unless otherwise stated. Use may be made of any material contained within the thesis for non-commercial purposes from the copyright holder. Commercial use of material may only be made with the express, prior, written permission of Universiti Putra Malaysia.

Copyright © Universiti Putra Malaysia



ABSTRACT

DETECTION OF COPPER ION USING AD5933 EVALUATION BOARD WITH INTERDIGITATED ELECTRODE (IDE)

By

AMZAR KHALILI BIN KHALID

198937

February 2022

Supervisor: Dr Nurul Huda binti Osman, PhD

Faculty: Science

Environmental contamination has become a major concern in many countries throughout the world. Copper, being a sort of solid waste, has the big potential to pollute the environment in a variety of ways. As a result, it is necessary to detect the presence of copper in order to take precautionary measures and prevent environmental consequences. The interdigitated electrodes (IDE) was chosen for detecting the presence of copper ions in this experiment for several reasons such as low cost, ease of manufacture, and great sensitivity. Chitosan films were used as adsorbent in order to help the IDE sensor in detecting the presence of copper in this research. Moreover, the AD5933 evaluation board and AD5933 Eval Software were used in this work measurement to detect the presence of copper ion in the copper solution by measuring the value of parameters to allow for portability of the measurement. The best parameter to be used in this method has been determined which is imaginary part of impedance, as it has the value the highest sensitivity of measurement with the value of gradient equal to 84.966, and also has high value of regression or R^2 that is 0.713 which indicates a high exactness in measurement as the value is close to 1.

ACKNOWLEDGEMENTS

First and foremost, I want to thank my family for always supporting my studies at the Universiti Putra Malaysia (UPM). I could not be any more fortunate to have such a wonderful and loving family. Not to be forgotten either, my kind-hearted supervisor, Dr. Nurul Huda, who supported me a lot and led me in this study until I manage to finish my research completely. In addition, I also want to thank brother Halim, master student in UPM, for helping and also guiding me in completing the project.



TABLE OF CONTENTS

Abstract.....	i
Acknowledgements.....	ii
Approval.....	iii
Declaration Form.....	iv
Table of Contents.....	v
List of Figures.....	vii
List of Table.....	viii
CHAPTER 1: INTRODUCTION.....	1
1.4 General Statement.....	1
1.4 Problem Statement.....	2
1.4 Objectives.....	2
1.4 Thesis Layout.....	2
CHAPTER 2: LITERATURE REVIEW.....	3
2.1 Reason of Detecting Copper Instead of Other Solid Waste.....	3
2.2 The Use of Interdigitated Electrode (IDE) and Its Application.....	4
2.3 Properties of AD5933 Evaluation Board and Its Application.....	5
2.3 Use of Chitosan as Adsorbent.....	7

CHAPTER 3: METHODOLOGY	9
3.1 Calculation of Copper Concentration.....	9
3.2 Calibration Process of AD5933.....	9
3.3 AD5933 Measurement with IDE.....	13
CHAPTER 4: RESULTS & ANALYSIS	14
4.1 Measuring Frequency and Reference Resistance using LCR Meter.....	14
4.2 Calculation of Parameter using AD5933 Evaluation Board.....	16
CHAPTER 5: CONCLUSION	21
References.....	22

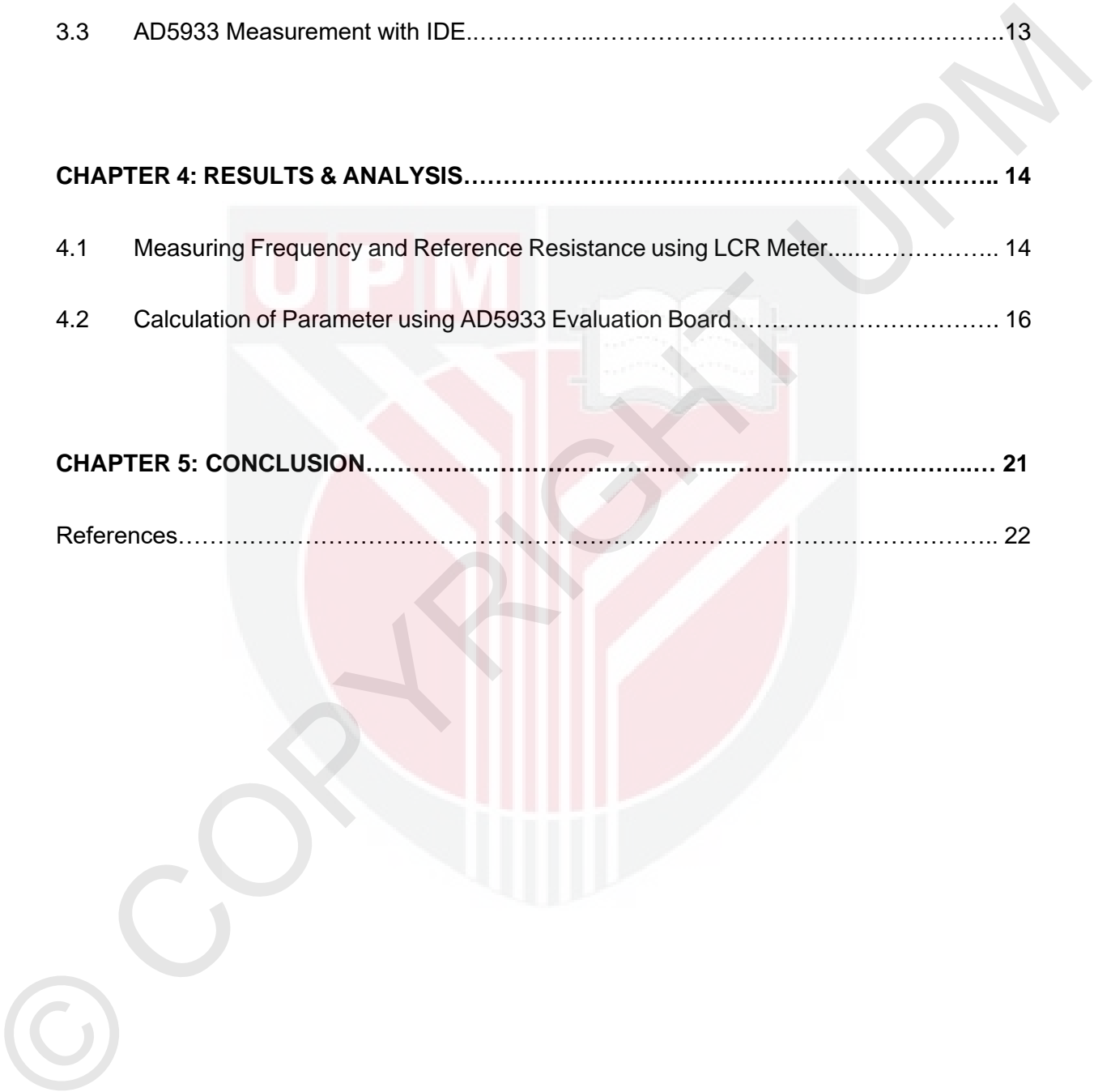

LIST OF FIGURES

Figure 1: Symbol and characteristics of copper element.....	3
Figure 2: The design of the IDE (a), and also the circuit or connection in the IDE (b) & (c)....	5
Figure 3: AD5933 Evaluation Board Block Diagram.....	6
Figure 4: The presence of particular functional groups in chitosan, such as amino and hydroxyl enables it to adsorb metal ion.....	7
Figure 5: HM8118 LCR Meter.....	10
Figure 6: Measurement of parameter using LCR meter.....	11
Figure 7: Connecting resistors to the board.....	12
Figure 8: The completion of calibration process for AD5933 Evaluation Board.....	12
Figure 9: Putting and clipping sample on IDE.....	13
Figure 10: Graph of Resistance versus Frequency.....	14
Figure 11: Graph of Impedance versus Concentration.....	17
Figure 12: Graph of Phase versus Concentration.....	18
Figure 13: Graph of Real versus Concentration.....	19
Figure 14: Graph of Imaginary versus Concentration.....	19
Figure 15: Graph of Magnitude versus Concentration.....	20

LIST OF TABLE

Table 1: The measured value of impedance, phase, real, imaginary and magnitude of the chitosan-copper polymer at 80 KHz.....17



CHAPTER 1: INTRODUCTION

1.1 GENERAL STATEMENT

The issues of environmental pollution have been on the rise throughout the countries all over the world. There are a lot of factors that contribute to the environmental pollutions such as greenhouse effect and solid waste. One of the primary sources of environmental contamination is land or solid waste pollution caused by poor solid waste management (Khan & Ghouri, 2011, as cited in Kimani, 2007). In this work, we will discuss more on copper as one type of solid waste that could bring many negative effects to the environmental pollution.

Shrivastava (2009) claimed that copper is an essential engineering substance and a preferred metal among engineers and scientists. It is a hazardous metal that has a wide range of health risks and biochemical impacts on living organisms. Solid waste from mines, mines water and effluents from water treatment plants, tailings from floatation processes, sulphur-containing fumes, bleed electrolyte from electro-refining plants, acid soilage from sulphuric acid plants, and so on are the primary causes of pollution in the copper metal business (Bhatia, 2002). Excessive Cu consumption can result in hemolysis, hepatotoxicity, and nephrotoxicity. Copper poisoning causes mucosal irritation, corrosion, extensive capillary damage, hepatic and renal damage, and central nervous system irritation, which results in depression (Shrivastava, 2009, as cited in Krishnarnurthy et al., 1991).

1.2 PROBLEM STATEMENT

It is compulsory to detect the presence of copper in order to make precaution steps and reduce the effects of pollution. However current methods of detection are still on lab based and didn't offer in-situ measurement. This might cause delay in detection and effort to contain

the pollution. Therefore, we proposed a simpler methods for early detection of copper ion, which is by using chitosan film along the interdigitated electrodes (IDE) and AD5933 Evaluation Board. The properties of IDE in detecting the copper with chitosan film have to be investigated besides identifying the value of parameters in chitosan and graphene to complete the experiment. Last but not least, the best parameter to be used in detecting copper have to be chose in order to get the best measurement for the in-situ method.

1.3 OBJECTIVES

1. To identify the changes in electrical parameters for different concentration of copper in chitosan film.
2. To determine the best parameter to be used in detecting copper using AD5933.

1.4 THESIS LAYOUT

This thesis is divided into several chapters. In the first chapter, the general statement, problem statement, objectives, and the thesis layout are being introduced. In the second chapter's literature review, the reasons for detecting copper rather than other solid waste, the properties of IDE as the standard approach, and the use of chitosan as adsorbent are explored. In the third chapter, there are further explanations on the method in handling the experiment such as calculation of concentration of copper, calibration process, and also measurement of parameters in detection of copper. Moreover, the results and analysis based on the experiments is being discussed. Finally, the last chapter summarizes the project's completion.

CHAPTER 2: LITERATURE REVIEW

2.1 Reason of Detecting Copper Instead of Other Solid Waste

Copper is one of the elements in solid waste that is widely found in many areas, especially in the industries. Industrial effluents from metal cleaning and plating baths, paper, paperboard mills, wood-pulp production, tyre manufacturing, and fertilizer sectors all contribute to elevated Cu levels in the environment (Agrawal et al., 2004). This copper waste will bring a lot of bad effects not only to the human, but also to the environment when consume it more than the limit. According to ISI standards, the acceptable limits for Cu in effluents onto land are 3.0 mg/L (Agrawal et al., 2004, as cited in Trivedi, 1995). Agrawal et al. (2004) also claimed that copper toxicity and gastrointestinal difficulties can occur as a result of excessive copper consumption. Even at extremely low concentrations, it is harmful to aquatic organisms. Thus, the copper element has the prior to be detected instead of other solid waste as it is widely used and also easily found in a lot of industries besides it could give various of harmful effects to human and environment. Figure 1 shows symbol and characteristics of copper element such as it atomic number, atomic weight, crystal structure and electron configuration.

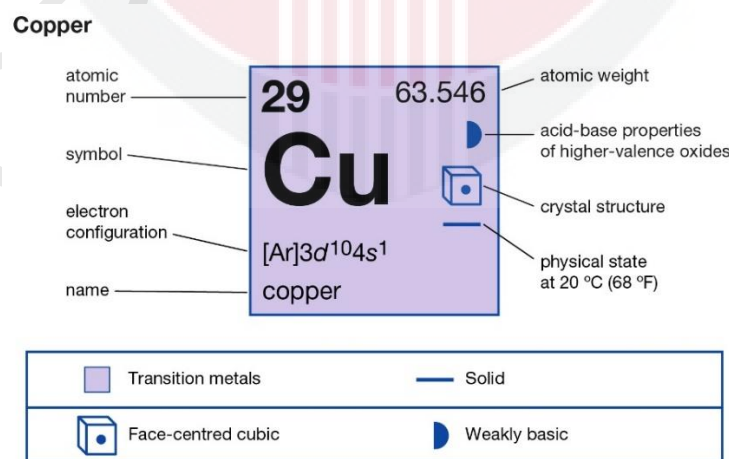

© Encyclopædia Britannica, Inc.

Figure 1: Symbol and characteristics of copper element

2.2 The Use of Interdigitated Electrode (IDE) and Its Application

There are various of standard method that could be used to detect the presence of copper element such as atomic absorption spectrometry (AAS), inductively coupled mass spectroscopy (ICP-MS), inductively coupled atomic emission spectroscopy (ICP-AES), by square-wave voltammetry-extraction iodometry at the liquid interfaces, by flame atomic absorption spectrometry and by using the interdigitated electrode (IDE). Each method has its own pros and cons. In example, the traditional methods such as AAS, ICP-MS, and ICP-AES are not suited for popularization and application because of the expensive instruments, time-consuming operation process, and high technical requirements for operators, these approaches (Jiang et al., 2019).

Interdigitated electrodes (IDEs) are made up of two interdigitated comb-like electrode structures that addressed independently and usually used in optimizing various sensing devices. The IDEs have been chosen to be the standard method to detect the presence of copper for several reasons. Mazlan et al. (2017) stated that due to their low cost, ease of manufacture, and great sensitivity, IDEs are one of the most extensively used transducers in technical applications, particularly in the field of biological and chemical sensors. The impedance and capacitance signals must be obtained in order to identify and analyze a biological molecule or analyte. The resistance and capacitance affect the impedance biosensor, while the dielectric permittivity affects the capacitance biosensor. Both impedance and capacitance biosensors are affected by the geometry and topologies of interdigitated electrodes. Figure 2 shows the design of the IDE (a), and also the circuit or connection in the IDE (b) and (c).

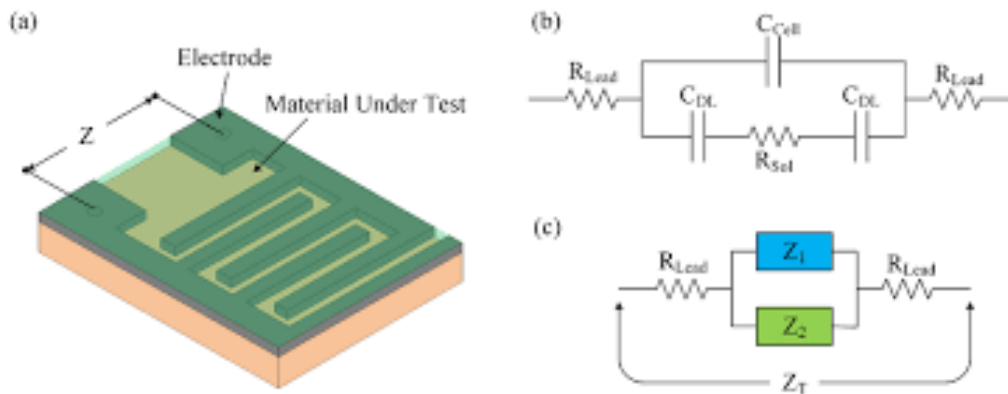

Figure 2: The design of the IDE (a), and also the circuit or connection in the IDE (b) & (c)

2.3 Properties of AD5933 Evaluation Board and Its Application

The AD5933 Evaluation Board is the main electronic device that is really important in this experiment or in this method, in order to measure the parameters such as impedance, angle phase and resistance. The AD5933 is a high-precision impedance converter system that includes a frequency generator and a 12-bit, 1 MSPS analog-to-digital converter (ADC). An external complex impedance can be activated with a known frequency using the frequency generator. Some of features and benefits of AD5933 Evaluation Board are full-featured evaluation board for the AD5933 and graphic user interface software with frequency sweep capability for board control and data analysis (Analog Devices, n.d.). In addition, Tawie and Daud (2018) stated that when compared to an impedance analyzer like the HP 4192A, the AD5933 is less expensive, portable, and offers a 1MSPS sample rate, which is fast enough for frequency sweeping. By directly measuring the electrical impedance of electromaterials, a sensing technique known as impedance approach has been widely used to exploit their coupling property. Changes in impedance response signals at specific frequencies can be utilised to detect structural integrity changes. Moreover, Garcia and Sabuncu (2019) also claimed that in small-scale medical applications, the AD5933 was thought to provide a low-

cost alternative for impedance analysis. Hoja and Lentka (2009) also affirmed that low power consumption and incorporation of most blocks required for impedance spectroscopy are two advantages of the AD5933 chip. Besides that, the AD5933 integrated circuit provided end users with greater flexibility, power, and size than previously available commercially accessible options (Simic, 2013). Therefore, the AD5933 has a lot of benefits and characteristics that make it suitable for this method in order to detect the concentration of copper.

There are several applications that use the AD5933 Evaluation Board such as in electrochemical analysis, impedance spectroscopy, and in complex impedance measurement. Breniuc and David (2014) described that the Analog Devices AD5933 circuit includes all of the hardware and software resources needed to build an impedance measurement and characterization system. Besides that, it is also use in corrosion monitoring and protection equipment, biomedical and automotive sensors, and proximity sensing. Figure 3 shows the AD5933 evaluation board diagram, where the important electrical components such as the reference resistor is connected.

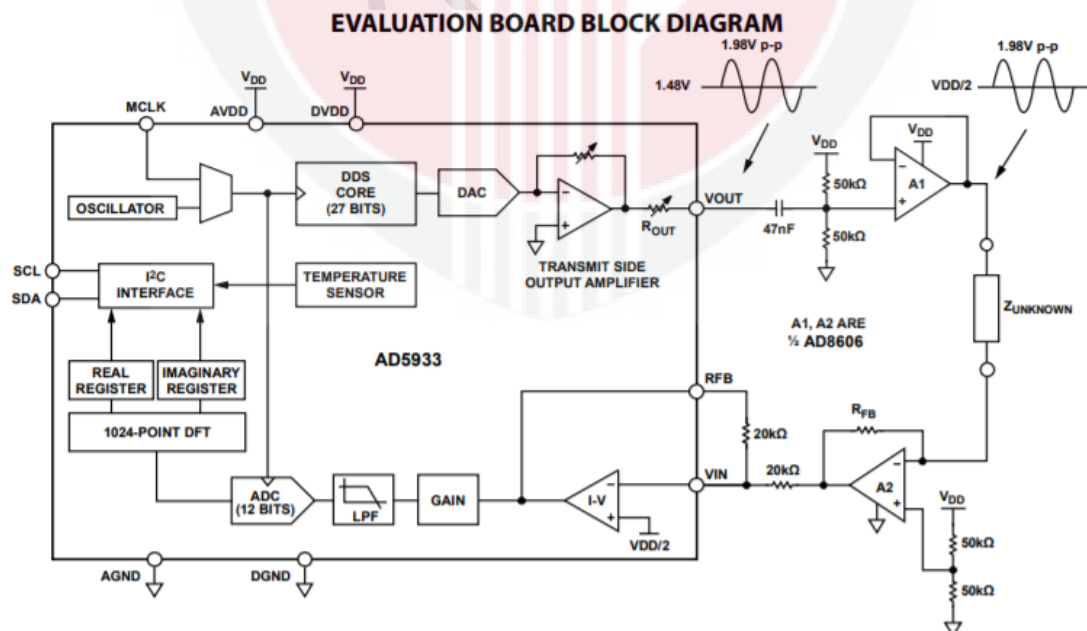

Figure 3: AD5933 Evaluation Board Block Diagram

2.4 Use of Chitosan as Adsorbent

One of the reasons of using the chitosan is because of chitosan has the ability to adsorb copper. Chitosan is a polymer ascribable to the presence of several functional groups in its chain. Lee (2017) explained that Chitosan is a potential biopolymer that is commercially available among all natural polymers. It is a well-known polysaccharide that is mostly made from chitin, and naturally occurring chitosan has piqued interest in recent decades due to its abundance in nature, biodegradability, and wide range of applications. Chitosan can be modified or functionalized to present specific properties such as hyaluronic acid interaction with chitosan-conjugated magnetite particles. The synthesis of chitosan-based magnetic adsorbents involves the preparation of chitosan and the magnetization process, which can occur simultaneously or separately. The final particles have a multicomponent structure and hybrid configuration with integrated properties from chitosan and from the magnetic component (Yang and Lee 2007). Figure 4 reveals the presence of particular functional groups in chitosan, such as amino and hydroxyl enables it to adsorb metal ion. Chitosan is a promising adsorbent of hazardous metals and has been widely explored to filter polluted water (Divya and Jisha 2018).

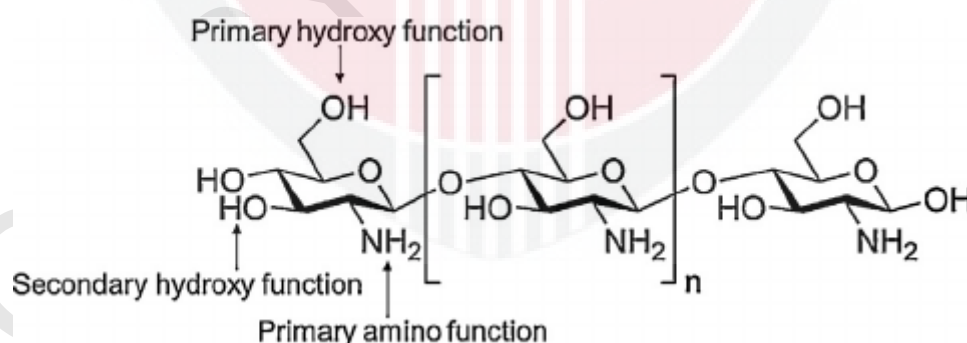

Figure 4: The presence of particular functional groups in chitosan, such as amino and hydroxyl enables it to adsorb metal ion.

In this experiment, the presence of Cu²⁺ ions may be identified with the use of the chitosan film. A ring resonator with chitosan film was demonstrated to be capable of detecting

the presence of Cu^{2+} ions adsorbed on the film at concentrations as low as 1 mg/l (Osman et al., 2018). Lee (2017) stated that because copper ions (Cu^{2+}) cause DNA damage, they have been classed as a possibly carcinogenic chemical. When malondialdehyde and 4-hydroxynonenal combine with lipid hydroperoxide, they form malondialdehyde and 4-hydroxynonenal, which can cause tissue damage. As a result, accurate detection of these ions is essential in a variety of industries. Thus, the AD5933 Evaluation Board has been chosen to be the method in this experiment in order to make the most accurate detection of the copper ion or Cu^{2+} .



CHAPTER 3: METHODOLOGY

3.1 Preparation of chitosan-copper standard

Five different samples of chitosan with different concentration of copper element inside the chitosan were prepared. The values of concentration used in this experiment were 2 ppm, 4 ppm, 8 ppm, 12 ppm, 16 ppm, and 20 ppm. Then, the concentration of copper in each sample was calculated by using the equation (1) to get the volume of copper ion needed.

$$M_1V_1 = M_2V_2 \quad (1)$$

Where,

M_1 = initial concentration of copper ion (1000 ppm)

V_1 = volume of copper solution needed

M_2 = final concentration of copper ions

V_2 = volume of deionized water (100 ml)

1% of acetic acid was then added to the prepared copper solution and mixed in volumetric flask. 1 gram of chitosan flakes (medium molecular weight) were weighted on the electronic balanced. The chitosan flake was then placed into a beaker before the prepared copper solution was added. The chitosan solution was then stirred at 600 rpm until all the chitosan was fully dissolved. The mixture was then poured into petri dish and dried in oven at 60°C for 24 hours. These processes were repeated for each copper concentration value required. The dried chitosan-copper film was then cut into smaller size and were keep in the desiccator to avoid moisture adsorption onto the film.

3.2 Calibration Process of AD5933

In general, the purpose of calibration is to minimize measurement uncertainty by

ensuring that test equipment is accurate. Calibration is the process of quantifying and controlling errors or uncertainties in measuring processes to an acceptable level. To ensure the AD5933 work as require, value of reference resistance and operating frequency must first be determined. This was done using a LCR meter.



Figure 5: HM8118 LCR Meter

LCR meters are measuring instruments that measure a physical property known as impedance. Impedance, which is expressed using the quantifier Z , indicates resistance to the flow of an AC current. It can be calculated from the current I flowing to the measurement target and the voltage V across the target's terminals. Wide frequency range with configurable frequencies, ability to measure primary and secondary parameters, and sweep function are the main criteria for LCR meter (Simic, 2014). Figure 5 shows one design or type of LCR meter which is HM8118 LCR Meter.

The LCR meter was first calibrated to ensure error in measurement was eliminated. After calibrating the LCR meter, the IDE was connected with LCR meter using the IDE holder and the impedance of samples was measured. The sample was place on the IDE and was clipped with a wooden clipper to ensure sample contacted with the IDE as shown in Figure 6. It was ensuring that the sample placement area is constant for all the sample. The value of

required parameter was then measured. The same steps were repeated for all five samples.

The values of impedance, resistance and frequency for all the samples were compiled in Table 2 and the graph of resistance versus frequency was plotted to determine the most suitable value of frequency to insert in the AD5993 Evaluation Board for the calibration process of the board. After the value of frequency was determined, then the value of reference resistance was calculated and readied for calibration of AD5933.



Figure 6: Measurement of parameter using LCR meter

The AD5933 Eval Software was downloaded and connected to the AD5933 evaluation board. After the evaluation board was connected to the software by using the USB cable connector, the calibration process must be done. To calibrate the AD5933 Evaluation Board, two resistors; the gain setting resistor (RFB) and Z calibration; with the same value as the calculated reference resistance value, was connected to the board such as in Figure 7. Then, the value of frequency and reference resistance was inserted in the setting of the board. To complete the calibration process, button “calculate”, “measure”, and “sweep” must be clicked. Figure 8 showed the process was done when the impedance’s value obtained must be the same as the physical resistor used.

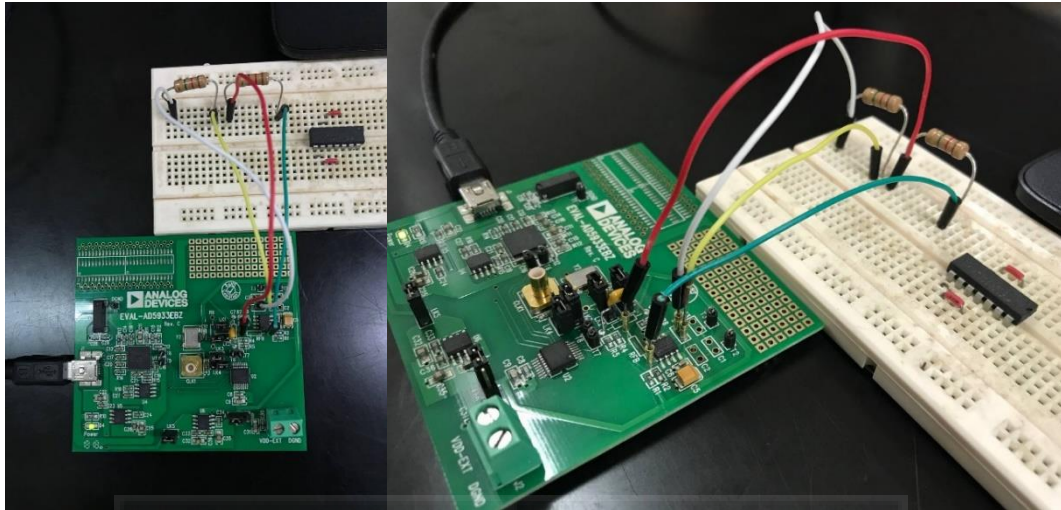

Figure 7: Connecting resistors to the board

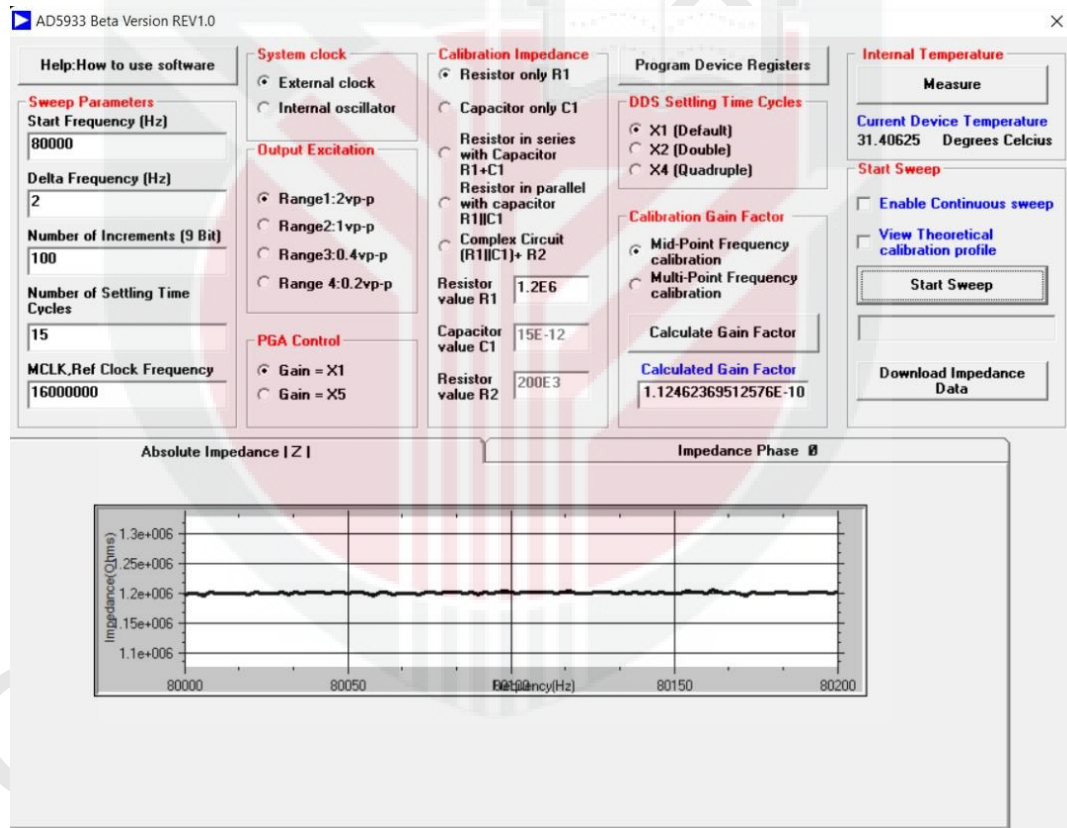

Figure 8: The completion of calibration process for AD5933 Evaluation Board

3.3 AD5933 Measurement with IDE

After completing the calibration process, the connection of resistor at RFB on the AD5933 board was replaced with IDE connector. Then the sample was placed on the IDE, such as in Figure 9, before the button “sweep” was clicked to obtain the value of the required parameters. The steps were repeated for the all samples and presented in Table 3.

Next, the graph of all the parameters versus concentration were plotted and the line equation for each graph was determined. The best parameter to be used in the detection was determined by the R^2 value and also the sensitivity based on the slope of the line. The difference of graphs for each parameter was discussed. Besides that, the graphs obtained from AD5933 Eval Software were compared with the graphs obtained from LCR meter and the difference was discussed.

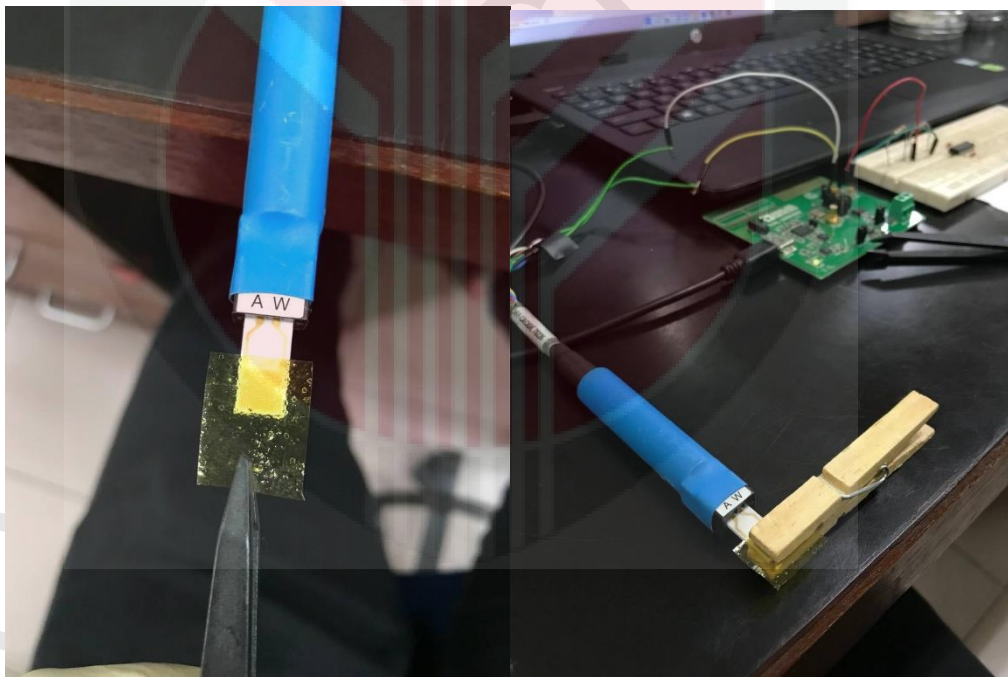

Figure 9: Putting and clipping sample on IDE

CHAPTER 4: RESULTS AND ANALYSIS

4.1 Measuring Frequency and Reference Resistance using LCR Meter

In this experiment, the value of most suitable frequency and reference resistance, to be used in measurement of parameters for AD5933 Evaluation Board, was determined. The value of that frequency and reference resistance could be identified by using the LCR meter. With IDE connected to the LCR the resistance of selected film was measured at frequency between 2 Hz to 100 kHz. The results of the measurement is shown in Figure 10.

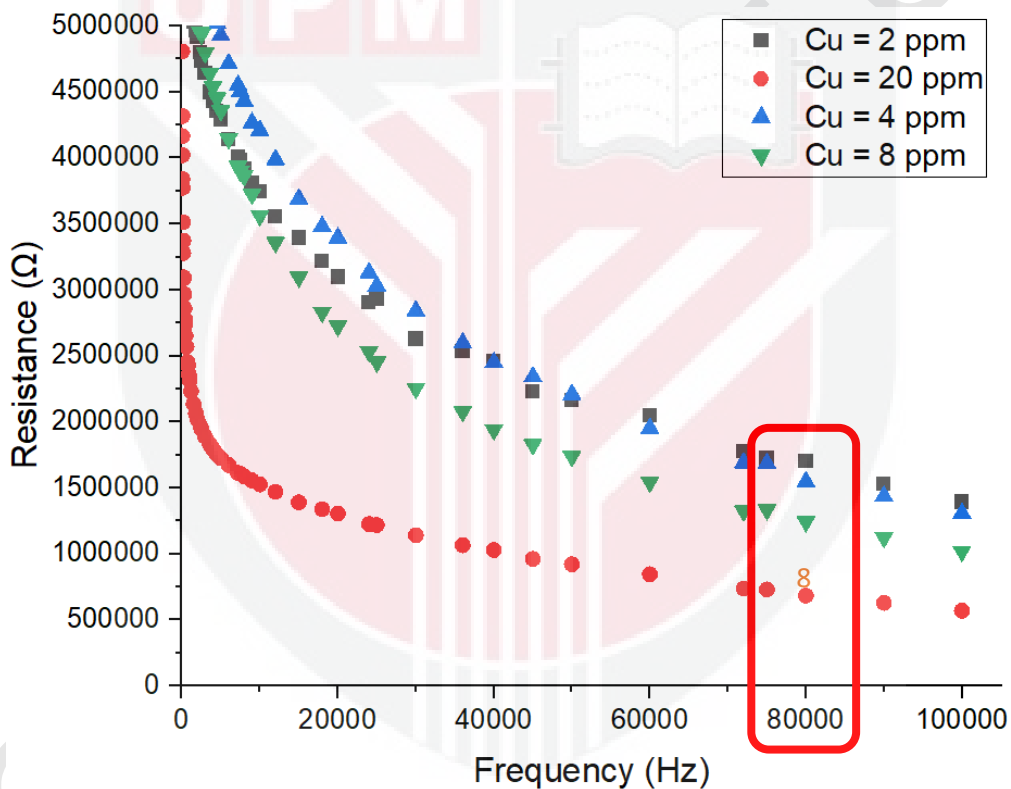

Figure 10: Graph of Resistance versus Frequency

From Figure 10, which is graph of resistance versus frequency, we could observe that the value of resistance is inversely proportional to the value of frequency. As we know, impedance is directly proportional with resistance and inversely proportional with frequency if the impedance is come from capacitive reactance.

Therefore, we will get the graph of resistance that is inversely proportional with the frequency. By comparing the result of measurement for all the samples, it was found that at 80,000Hz frequency was the effective value to be used in measuring the parameter by using the AD5933 Evaluation Board. This is because the pattern of resistance measurement for different concentration of samples at 80,000 Hz is following the actual pattern, where the value of resistance decreases when the concentration of copper in the film increases. Based on the formula,

$$\Lambda_m = \frac{K}{C} \quad (2)$$

Where,

Λ_m = molar conductivity such as resistance

K = specific conductivity

C = concentration in mole per litre

Sergei, S. (2014) explained that with increasing molarity, sheet resistance decreased rapidly. The improvement in crystallinity and thickness of the films may have resulted in a reduction in sheet resistance. Therefore, the 80,000Hz frequency would be the most effective value to be used in measuring the parameter by using the AD5933 Evaluation Board. However, there might be errors in the other frequencies as the patterns of resistance measurement are not following the actual pattern. One of the errors might be the effect of the force on the IDE that come from the other things such as the clipper. This might distract the measurement of the resistance and other parameters through the IDE.

After the value of frequency was determined, then the value of reference resistance was calculated by using the formula:

$$\text{Mean of } R = \frac{(R_h - R_l)}{2} \quad (3)$$

R_h = Highest value of resistance for 80000Hz

R_l = Lowest value of resistance for 80000Hz

By inserting 684146Ω as R_l and 1705443Ω as R_h , we got the mean value of R or the reference resistance was $1.2M\Omega$.

4.2 Calculation of Parameter using AD5933 Evaluation Board

In this experiment, the parameters considered are impedance, real part of the impedance, imaginary part of the impedance, phase angle, and magnitude of the impedance. Among the parameters, we have to observe which parameters could give the most exact value of concentration of copper. To do that, graph of each parameters versus concentration have to be plotted from the value obtained in Table 1. Then an equation for each graph that indicates the pattern of the graph need to be identified and the gradient of the graph will show the sensitivity of the measurement. The closer the value of the value of R^2 to 1, the more the exactness of the measurement. Thus, we could use the equation of that parameter to determine the value of parameter at any concentration of copper solution.

Table 1: The measured value of impedance, phase, real, imaginary and magnitude of the chitosan-copper polymer at 80 KHz.

Concentration, (ppm)	Impedance, (Ω)	Phase ($^{\circ}$)	Real (Ω)	Imaginary (Ω)	Magnitude (Ω)
2	637006.2	2.469980	17196.56	-10441.8	20146.71
4	636523.1	3.219478	17344.94	-10223.8	20161.99
8	636578.2	3.306841	17358.97	-10196.4	20160.23
12	636846.0	1.109562	16947.37	-10849.4	20151.78
16	637685.0	-1.440210	16424.81	-11576.3	20125.29

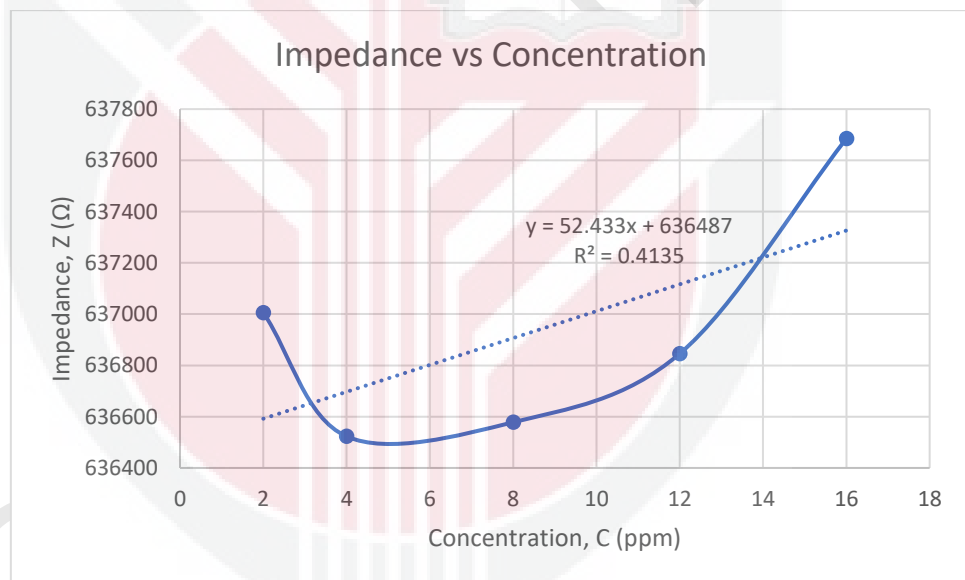

Figure 11: Graph of Impedance versus Concentration

In Figure 11, it shows that the value of impedance increase exponentially with the concentration follows the equation of $y = 52.433x + 636487$. The value of gradient is 52.433 which is quiet high. This shows that the impedance has a great sensitivity of measurement. However, the value of regression of the equation or the R^2 is low, which is 0.4135. It is quiet far from 1, that shows the exactness of measurement using the impedance is low.

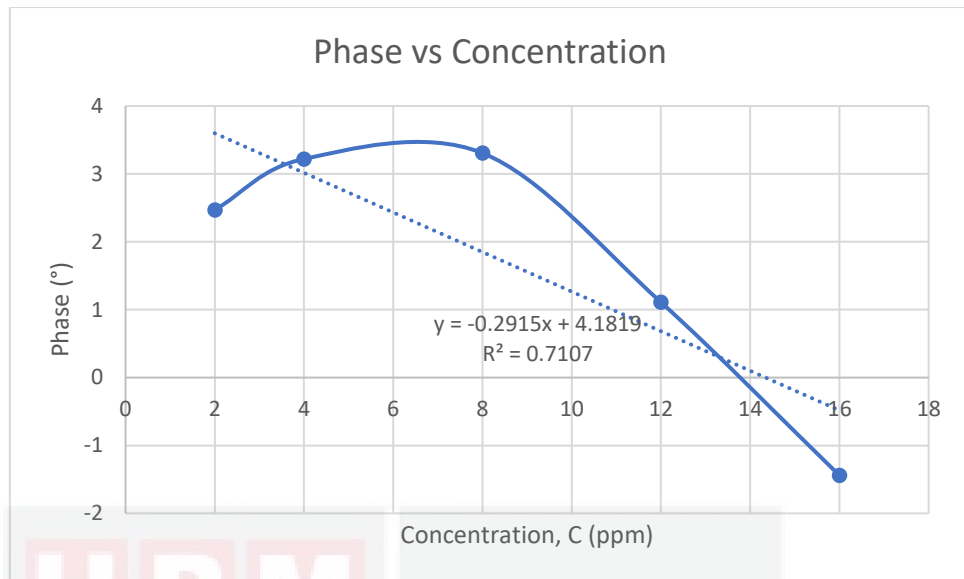

Figure 12: Graph of Phase versus Concentration

In Figure 12, it reveals that the value of phase angle is inversely proportional with the concentration follows the equation of $y = -0.2915x + 4.1819$. The value of gradient is 0.2915 which is the lowest compared to the other parameters. This indicates the sensitivity of measurement using the phase angle is also very low and not suitable to detect the presence of copper, despite of the exactness of measurement if using the phase angle is quiet high compared to the impedance, magnitude of impedance, and real part of impedance, with value of R^2 is equal to 0.7107.

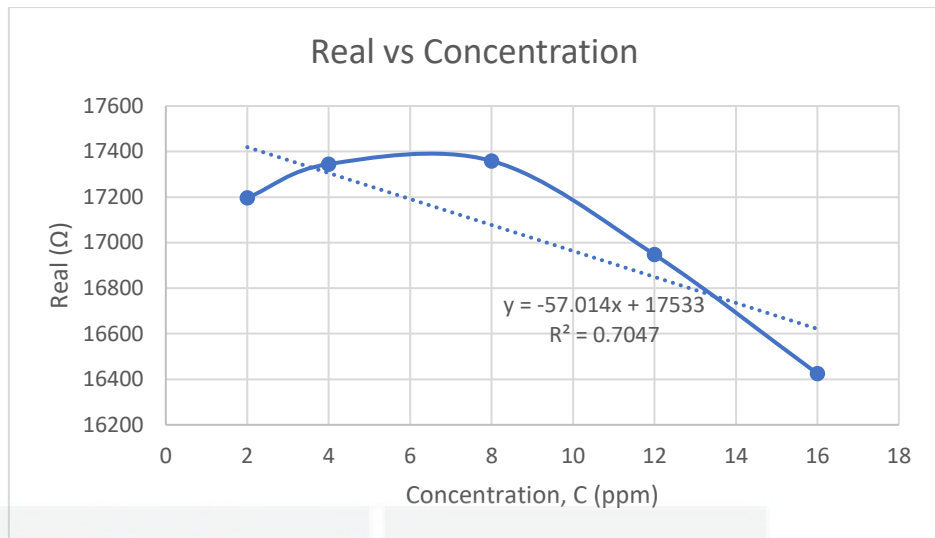

Figure 13: Graph of Real versus Concentration

Next, in Figure 13, it shows that the value of real is also inversely proportional with the concentration follows the equation of $y = -57.014x + 17533$. The value of gradient is 57.014 which is higher than the gradient in the equation for impedance, phase angle, and magnitude of impedance. The value of R^2 is 0.7047, which is also high compared to the other parameters. This shows that real has quiet great sensitivity and exactness in measurement and maybe suitable to be used in this method to detect the concentration of copper in any state.

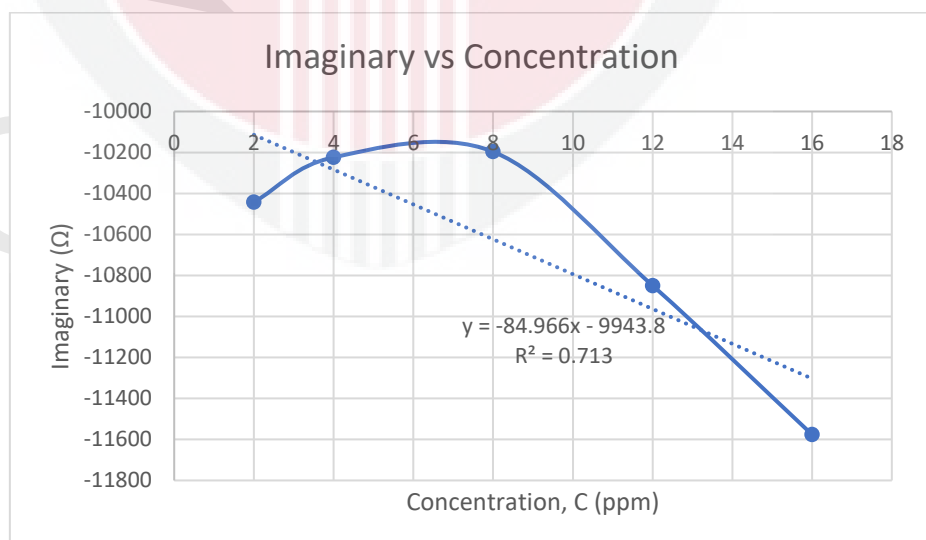

Figure 14: Graph of Imaginary versus Concentration

Equation of graph in Figure 14 has the highest value of gradient of equation which is 84.966. It also has the value of R^2 which is equal to 0.713, that is quiet close to 1. These expresses that imaginary has the greatest sensitivity in measurement with high exactness in measurement, which makes the imaginary part of impedance to be the best parameter to be used in detecting the concentration of copper for this method. Besides that, the negative value of gradient shows that the parameter is more capacitive as the reactance might be capacitive reactance.

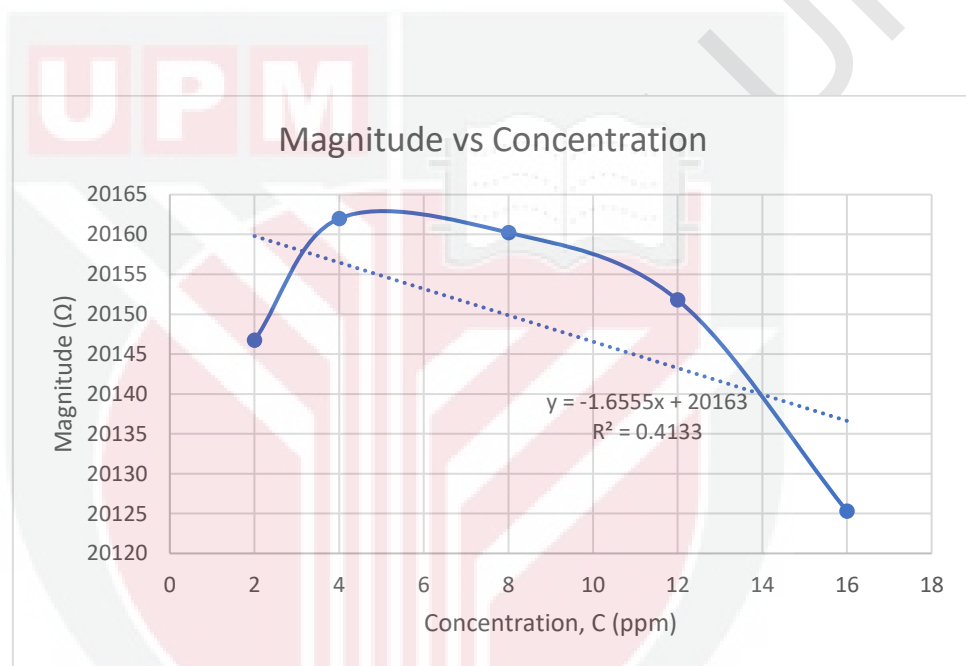

Figure 15: Graph of Magnitude versus Concentration

Last but not least, Graph 15 indicates that the value of phase angle is inversely proportional with the concentration follows the equation of $y = -1.6555x + 20163$. The magnitude of impedance has very low sensitivity of measurement with value of gradient equal to 1.6555 and also has very low exactness of measurement with value of regression or R^2 equal to 0.4133, which is quiet far from 1. This shows that magnitude of impedance is not suitable to be used as parameter in measuring the copper's concentration for this method.

CHAPTER 5: CONCLUSION

As conclusion, the presence of copper could be detected by using the interdigitated electrodes (IDE) and AD5933 Evaluation Board. The properties of IDE such as low cost, ease of manufacture, and great sensitivity make it a best standard method to detect the presence of copper in this project. Besides that, the changes of parameter in copper films could also be identified by the help of chitosan. The characteristics of chitosan such as could adsorb the copper ion help to detect the presence of copper ion easily in this experiment. Moreover, the best parameter to be used in this method has been determined which is the imaginary part of impedance, as it has the value the highest sensitivity of measurement with the value of gradient equal to 84.966, and also has high value of regression or R^2 that is 0.713 which indicates a high exactness in measurement as the value is close to 1. Last but not least, the negative value of gradient of equation for the imaginary indicates that the parameter is more capacitive as the reactance might be capacitive reactance.

REFERENCES

Khan, Mashhood Ahmad and Ghouri, Arsalan Mujahid, Environmental Pollution: Its Effects on

Life and Its Remedies (July 1, 2011). Researcher World: Journal of Arts, Science & Commerce, Vol. 2, No. 2, pp. 276-285, 2011, Available at SSRN: <https://ssrn.com/abstract=1981242>

Shrivastava, A. K. (2009). A review on copper pollution and its removal from water bodies by pollution control technologies. Indian Journal of Environmental Protection, 29(6), 552-560. Agrawal, A., Sahu, K. K., & Pandey, B. D. (2004). *A Comparative Adsorption Study of Copper on Various Industrial Solid Wastes*. Vol. 50, No. 10, pp. 1, 2004 <https://core.ac.uk/download/pdf/297711537.pdf>

Jiang, S., Lu, Z., Su, T., Feng, Y., Zhou, C., Hong, P., Sun, S., & Li, C. (2019). *High Sensitivity Detection of Copper Ions in Oysters Based on the Fluorescence Property of Cadmium Selenide Quantum Dots*. Retrieved from <file:///C:/Users/User/Downloads/chemosensors-07-00047-v2.pdf>

Mazlan, N. S., Ramli, M. M., Abdullah, M. M. A. B., Halin, D. C., Isa, S. M., Talip, L. F. A., ... & Murad, S. Z. (2017, September). Interdigitated electrodes as impedance and capacitance biosensors: A review. In AIP Conference proceedings (Vol. 1885, No. 1, p. 020276). AIP Publishing LLC.

Osman, N., Idris, A., Bakar, P. A., Majid, M. M. A., Radzali, R., & Liew, J. Y. C. (2018).

Detection of copper (II) ion on chitosan film using microstrip ring resonator.

International Journal of Nanoelectronics and Materials, 11, 179-186.

Shivan Ismael Abdullah & M.N.M. Ansari (2015) Mechanical properties of graphene oxide

(GO)/epoxy composites, HBRC Journal, 11:2, 151-156, DOI:

10.1016/j.hbrcj.2014.06.001

Yang P-F, Lee C-K (2007) Hyaluronic acid interaction with chitosanconjugated magnetite

particles and its purification. Biochem Eng J 33:284–289.

<https://doi.org/10.1016/j.bej.2006.11.010>

Divya, K., Jisha, M.S. Chitosan nanoparticles preparation and applications. Environ Chem

Lett 16, 101–112 (2018). <https://doi.org/10.1007/s10311-017-0670-y>

Sergeenkov, Sergei. (2014). Re: Change of resistance with molarity - any thoughts?.

Retrieved

from:

https://www.researchgate.net/post/Change_of_resistance_with_molarity-

[any_thoughts/53e381fccf57d7d9558b4672/citation/download.](https://www.researchgate.net/post/Change_of_resistance_with_molarity-any_thoughts/53e381fccf57d7d9558b4672/citation/download)

Garcia, A., & Sabuncu, A. C. (2019). Electrical system for bioelectric impedance using AD5933 impedance converter. *SMU Journal of Undergraduate Research*, 2(1), 3.

M. Simic, "Realization of Complex Impedance Measurement System Based on the Integrated Circuit AD5933," 2013 21st Telecommunications Forum Telfor (TELFOR), 2013, pp. 573-576, doi: 10.1109/TELFOR.2013.6716294.

Hoja, J., & Lentka, G. (2009, September). Portable analyzer for impedance spectroscopy. In XIX IMEKO World Congress Fundamental and Applied Metrology (pp. 497-502).

Tawie, R., & Da'ud, E. (2018, September). Low-cost impedance approach using AD5933 for sensing and monitoring applications. In *IOP Conference Series: Materials Science and Engineering* (Vol. 429, No. 1, p. 012104). IOP Publishing.

Lee, H. M., Kim, M. H., Yoon, Y. I., & Park, W. H. (2017). Fluorescent property of chitosan oligomer and its application as a metal ion sensor. *Marine Drugs*, 15(4), 105.