



UNIVERSITI PUTRA MALAYSIA

***DESIGN OF A DEVICE TO SAMPLE AMMONIA GAS EMISSION FROM
FLOODED RICE SYSTEM***

NUR NABILAH NOOR AZMI

**Ip
FK 2019 80**

**DESIGN OF A DEVICE TO SAMPLE AMMONIA GAS EMISSION
FROM FLOODED RICE SYSTEM**

NUR NABILAH BINTI NOOR AZMI

184872

**A final year project submitted in partial fulfillment of the requirement for degree of
Bachelor of Engineering (Agricultural and Biosystems) for Department of
Biological and Agricultural Engineering,
Faculty of Engineering,
Universiti Putra Malaysia**

JUNE 2019

ACKNOWLEDGEMENT

In the name of God, the Most Gracious, the Most Merciful.

With boundless love and appreciation, I would like to extend my heartfelt gratitude to the people who has helped me bring this study to reality.

First and foremost, I would like to offer this endeavor to God Almighty for the wisdom He bestowed upon me, the strength, peace of mind and good health in order to finish this project.

I am highly indebted to my supervisor, Dr. Nurulhuda Khairudin of Department of Biological and Agriculture Engineering, Universiti Putra Malaysia for her constant supervision and as well as for providing necessary guidance and information regarding this study. Without her expertise, this project would not successfully completed.

For lab assistants, Mr. Hamed, Mr. Sabri and Mr. Anuar and Mr. Zainal, thank you for the technical helps and suggestions.

I also would like to express my special gratitude to my beloved parents, Noor Azmi bin Moharad and Jamiyah Fairuz binti Mohammad for their encouragement and always be there when I needed emotional and financial supports.

Many thanks and appreciations for friends, and everyone who willingly helped me directly or indirectly throughout my journey and kept me going.

ABSTRACT

Ammonia gas volatilization in agriculture sector mainly in flooded rice systems needs to be studied in order to increase yield and productivity and reduce losses mainly in terms of economic. However, there is no research that have been conducted to measure how much ammonia gas loss from nitrogen containing fertilizers applied in flooded rice fields in Malaysia. Monitoring the ambient ammonia concentration at paddy fields and its surrounding is important because in Malaysia, residential area are located nearby. Excessive ammonia exposure at high concentration and long period of time can cause burning of the nose, throat and respiratory tract meanwhile for low concentrations can cause coughing, and nose and throat irritation. Readily available ammonia detector and sensors are sold at high price or with limitations such as detection limit where it cannot detect ammonia gas at a low concentrations since ammonia levels in the natural atmosphere can be very low due to wind and temperature. The gas analysis setup also should include a selective mechanism that only significant gas can affect the detector's surrounding system. In this study, a simple device to sample the ammonia gas at a low concentrations in flooded rice system is designed.

Table of Contents

ACKNOWLEDGEMENT	1
ABSTRACT.....	2
LIST OF TABLES	5
LIST OF FIGURES	5
CHAPTER 1	7
INTRODUCTION	7
1.1 Overview.....	7
1.2 Problem statements	8
1.3 Objectives.....	9
CHAPTER 2	10
LITERATURE REVIEW.....	10
2.1 Mechanism of ammonia volatilization	10
2.2 Mechanism of ammonia volatilization in flooded rice fields	12
2.3 Current status of ammonia volatilization.....	12
2.4 Factors increasing ammonia volatilization	16
2.5 Ammonia volatilization problems to health and environment	17
2.5.1 Issues on environment	17
2.5.2 Issues on health	18
2.6 Methods for determining the volatilization of ammonia.....	18
2.6.1 Direct methods	18
2.6.2 Wind tunnel method	20
2.6.3 Horizontal flux method.....	20
2.6.4 High-resolution measurement of ammonia emissions	22
2.7 Summary	23
CHAPTER 3	24
MATERIALS AND METHOD	24
3.1 Study Procedure	24
3.2 Available micrometeorological sampler for gas collecting.....	26
3.2.1 Zurcher passive sampler	26
3.2.2 Leuning ammonia sampler	27
3.2.3 Ogawa sampler	28
CHAPTER 4	30
RESULTS AND DISCUSSION	30
4.1 Results.....	30
4.1.1 Design of sampler.....	30

4.1.2	Conceptual design	30
4.1.3	Materials.....	33
4.1.4	Dimensions of sampler	36
4.1.5	Cost	39
4.2	Discussions.....	40
4.2.1	Fabrication difficulties encountered	40
4.2.3	Advantages and disadvantages of sampler.....	41
4.2.4	Limitations	42
4.2.5	Improving the sampler.....	42
CHAPTER 5		43
CONCLUSION AND RECOMMENDATIONS		43
5.1	Conclusion	43
5.2	Recommendations	43
REFERENCES		44
APPENDICES		47

LIST OF TABLES

Table 1 : Estimation of Nitrogen (N) flux from Asia in 1999/2001 and 2030.....	13
Table 2 : Ammonia emission in Asia countries based on emission sources.....	13
Table 3 : Review of concentrations of observed NH ₃ at different locations.....	14
Table 4 : List of items and price per unit.	39
Table 5 : Costing for 3D printing.	39
Table 6 : Total material cost for a unit of sampler.....	40

LIST OF FIGURES

Figure 1 : Nitrogen cycle, with emphasis on volatilization of ammonia	11
Figure 2 : Nitrogen transformation in submerged soil.....	12
Figure 3 : Enclosure(a) and Venting(b) methods.....	19
Figure 4 : Wind tunnel method for determination of ammonia volatilization	20
Figure 5 : Simple passive sampler	21
Figure 6 : Diagram of the ammonia emission on-line measurement system	23
Figure 7 : Procedure of designing ammonia gas sampler device.....	25
Figure 8 : Zurcher sampler with dimensions in mm	26
Figure 9 : Custom protection box for Zurcher sampler	27
Figure 10 : Leuning sampler schematic diagram	28
Figure 11 : Ogawa sampler	28
Figure 12 : 3D drawing of sampler	30
Figure 13 : Sectional drawing of the sampler	31
Figure 14 : Fabricated sampler.....	31
Figure 15 : Stainless steel assemble inside sampler body.....	32
Figure 16 : Stainless steel shim 0.05 mm and 0.1 mm.....	33
Figure 17 : Epoxy resin and hardener	34

Figure 18 : Process of making fin and the fittings35

Figure 19 : Early stage of printing process36

Figure 20 : Dimensions of sampler (in mm)36

Figure 21 : Dimensions of funnel (in mm).....37

Figure 22 : Dimensions of stainless steel assembly (in mm).....37

Figure 23 : Dimensions for fin (in mm).....38



CHAPTER 1

INTRODUCTION

1.1 Overview

Nitrogen fertilizers are necessary for the rice crop growth and in increasing the yield. It promotes rapid growth of plants and improves the yield and quality of grains. Stunted plants with small yellowish green leaves and fewer tillers are symptoms of nitrogen deficiency. In agricultural systems, the application of fertilizers that contain nitrogen are very broadly used. Losses of ammonia volatilization in flooded soils range from insignificant to nearly 60% of the nitrogen used (Choudhury & Kennedy, 2005).

In flooded rice systems, ammonia volatilization occurs at the surface of the flood water where nitrogen containing fertilizers are applied. As urea $\text{CO}(\text{NH}_2)_2$ is easily hydrolysed to ammonium carbonate $((\text{NH}_4)_2\text{CO}_3)$ in water, the carbon dioxide (CO_2) produced starts to convert to bicarbonate ion (HCO_3^-) resulted in increasing value of pH. High pH value in soil is one of the factors of increasing ammonia volatilization.

The use of carbon dioxide by algae and other aquatic life for their photosynthetic operations increases floodwater pH, resulting in significant losses of N due to volatilization of ammonia. Ammonium ions are weakly bonded to water molecules and converted into non-ionized ammonia (NH_3), which can leave water as gas.

Another causes of increasing ammonia volatilization includes low rainfall frequency, moist soil or soil with high moisture content, high wind velocity, high soil temperature, low cation exchange capacity soil and poor buffering of soil.

Ammonia when reacts with sulphate or nitrate could produce aerosol particles. This aerosol does not absorb sunlight but reflect it, thus reducing the amount of sunlight reaching the surface of the Earth. Ammonia is extremely toxic to aquatic organisms, and its concentration in U.S. water has been regulated to a maximum of 0.02 mg/L (U.S. Environmental Protection Agency, 1977).

1.2 Problem statements

The study of ammonia volatilization in agriculture has been conducted around the world especially in the United States, Vietnam, China and other agriculture practicing countries. The study of ammonia volatilization in flooded rice systems need to be conducted in Malaysia since this country yield about 2.5 metric ton per hectare of rice in 2016. Comparing to other ASEAN countries such as Thailand, Indonesia, Philippines and Vietnam, Malaysian rice production remained relatively constant in comparison with other countries, which showed a growing trend since 1990 (Omar, Shaharudin, & Tumin, 2019).

The volatilization of ammonia from the utilization of nitrogen based fertilizers can cause much losses to farmers. If the amount of volatilization is up to 60% of the N applied on the field, there would be such a terrible waste of cost for them because only few of the remaining N applied will be utilized by the crop, not accounting other N losses by different paths.

A simple device needed to be created for the farmers so that they can keep track of how much N are dissipated through ammonia volatilization.

1.3 Objectives

The main objective of this project is to design a device to sample ammonia gas in flooded rice systems. The specific objectives of this project are :

- I. To study and compare the existing methods for measuring ammonia volatilization.
- II. To design a device for sampling ammonia gas in the air.
- III. To fabricate the designed device.



CHAPTER 2

LITERATURE REVIEW

2.1 Mechanism of ammonia volatilization

Ammonia (NH₃) volatilization takes place roughly two or three weeks after fertilizer use, as previous research suggested (Bouwman et al., 2002; Zhang et al., 2005; Su et al., 2007; Li et al., 2008). This reaction depends on the hydrolysis of the urea itself. We can see the mechanism of ammonia volatilization through these chemical reactions :

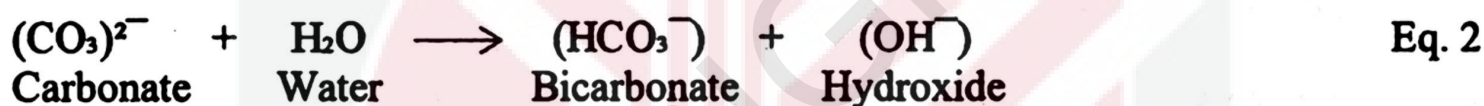
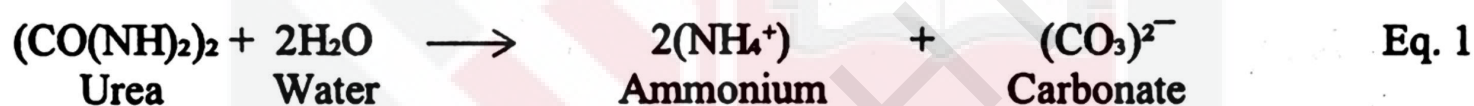

In Eq. 1, the hydrolysis process occurs when the urea is applied on a moist soil or soil with high humidity with the help of urease enzymes that found naturally in the soil. Moving on to Eq. 2, hydroxide produced increase the soil pH temporarily and increase the rate of ammonia volatilization.

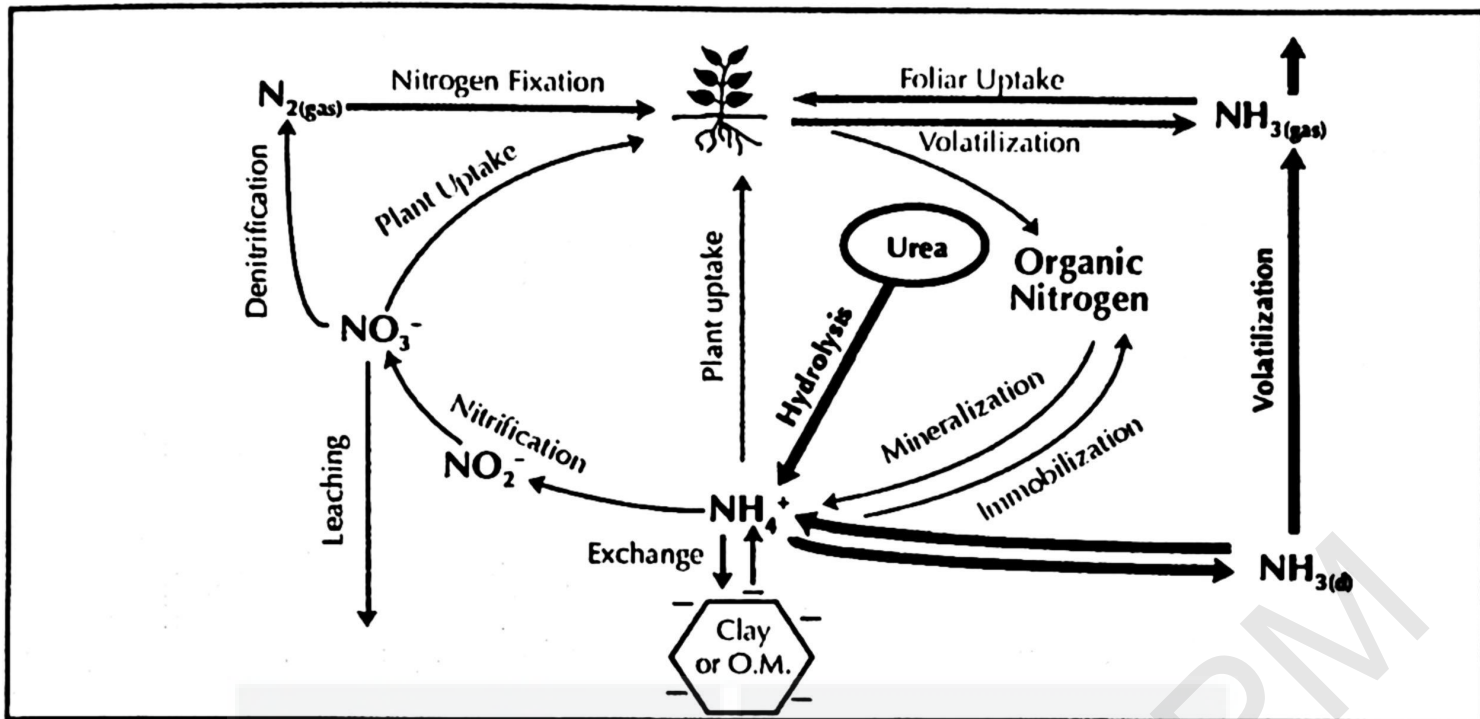

Figure 1 : Nitrogen cycle, with emphasis on volatilization of ammonia (Clain et al., 2007)

The type of soil was found to be the major factor responsible for loss of ammonia volatilization in direct seeding paddy fields. The greatest volatilization rates of ammonia were found in mildly salt-affected soil and obtained after the application of the fertilizer on the third day. The peak ammonia volatilization rate reached almost 6.5 kg·N/ha a day in slightly salt-affected soil. Ammonia volatilization during the seasonal growing period accounted for 35.6%–38.0% of total N applied in the Taihu Lake region of Southeast China (Li et al., 2017).

2.2 Mechanism of ammonia volatilization in flooded rice fields

In flooded rice systems, the floodwater zone is where ammonia volatilization occurred.. Ammonium based fertilizers dissociate straight from NH_4 , while urea may break down to generate NH_4^+ ions by catalytic hydrolysis. When NH_4^+ is transformed to NH_3 gas, volatilization can cause it to be lost into the ambience. This is a significant consequence of N loss for rice fields that have been flooded with water.

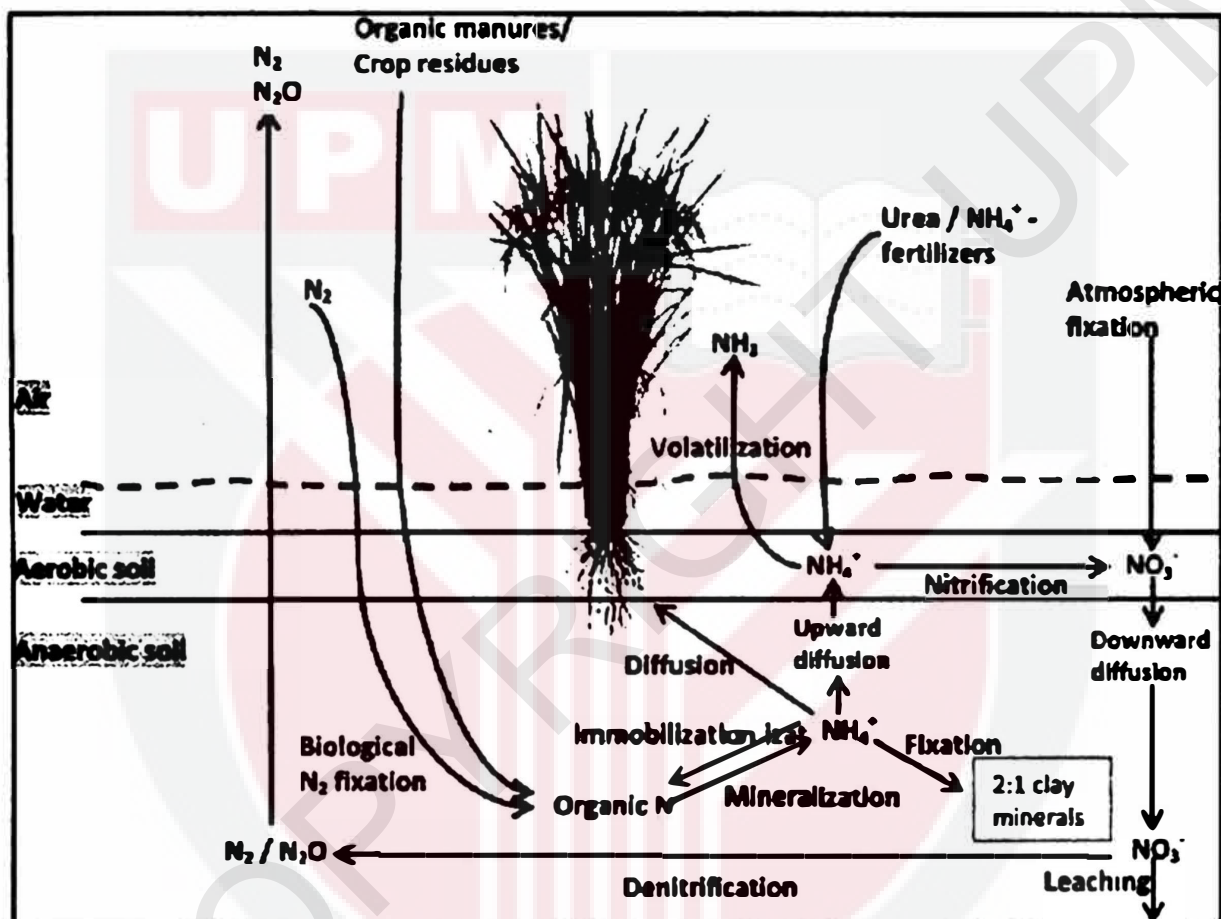

Figure 2 : Nitrogen transformation in submerged soil (Chauhan, Jabran & Mahajan, 2017)

2.3 Current status of ammonia volatilization

It has been brought into being that, in the worldwide, up to 64% (a standard of 18%) of utilized N was lost as NH_3 . As a species of reactive nitrogen, ammonia (NH_3) is lost via volatilization as one of the main pathways of N loss in farming systems. While more than 40% of the N applied is described as being lost as NH_3 under certain ambient and edaphic conditions (Singh et al., 2013), an average of 14% of N is lost via volatilization from artificial fertilizers (Bouwman et al., 2002. De Klein et al.,

2006). In China, the total NH_3 discharge was reckoned to be 13.6 Tg for 2000, of which 50% comes from fertilizer applications and another 38% from other sources of agriculture (Streets D. G. , 2003).

Previous results showed that the amount of nitrogen lost via ammonia volatilization during the rice growing season accounted for 9% to 40% of the total nitrogen applied (Lin et al., 2012).

Asia's NH_3 emissions are 19.3 Tg/yr, 46% of the world's total. The main source is volatilization from livestock manufacturing and rural human waste, which accounts for 62% of total emissions, and the residual 38% is from nitrogen fertilizer implementation (Zhu, Xiong, & Xing, 2005).

Table 1 : Estimation of Nitrogen (N) flux from Asia in 1999/2001 and 2030 (Zhu et al., 2005)

	Year	East	South	South	Central	West	Asia
		Asia	East Asia	Asia	Asia	Asia	Total
NH_3 emission (Tg/yr)	1999/2001	8.9	1.9	6.9	0.27	1.4	19.3
	2030	11.2	2.4	8.8	0.41	2.2	25.0

Table 2 : Ammonia emission in Asia countries based on emission sources (Zhu et al., 2005).

	Year	Total emissions (Tg/yr)	Source (in % of the total)		
			Fertilizer N	Animal excreta	Human excreta
NH_3 emissions	1999/2001	19.3	38	53.7	8.4
	2003	25	40.3	53.6	6.4

Table 3 : Review of concentrations of observed NH₃ at different locations (Wang et al., 2015).

Placement	Type	Span	NH₃ (ppb)	Approach
Shanghai	Urban	2013.7–2014.9	6.2 ± 4.6	DOAS
China	Rural	2013.7–12, 2014.3–6	12.4 ± 9.1	MARGA
	Industrial	2014.1–6	17.6 ± 9	DOAS
Beijing	Urban	2007.1.23–2.14	7.21 ± 4.941	Annular Denuder
China		2007.8.2–31	33.46 ± 9.111	
Beijing	Urban	2008.2–2010.7	22.8 ± 16.3	Passive Sampler
China	Rural	2007.1–2010.7	10.2 ± 10.8	
North Plain	Rural sites	2008.8–2009.9	20.61	Passive Sampler
Kampur India	Urban	2007.4.8–6.30 2007.12.1– 2008.1.31	23.7 ± 5.11 21.5 ± 6.61	Online NO _x –NH ₃
Seoul	Urban/GJ	2010.9.1– 2011.8.23	10.9 ± 4.25	WS-CRDS2
Korea	Urban/GS		12.3 ± 4.23	
Lahore	Urban	2005.12– 2006.2	30.3–116.9	Annular Denuder
Taiwan	Industrial	2003.9– 2004.12	100.2	Passive Sampler
USA	Urban/Atlanta	2007.7–12	1.35 ± 1.19	Citric Acid Denuder

	Rural/Georgia		3.32 ± 2.37	Difference Technique
Houston, TX	Urban	2010.2.12–3.1	2.42 ± 1.16	EC-QCL-based
USA		2010.8.5–9.25	3.07 ± 2.87	sensor3
Wisconsin	Urban	2009.1.1–3.31	2.3	iCAMs4
USA	Rural		2.4	
USA	Forest/Brent	2013.6.1–7.15	1–2	CIMS5
	Urban/Kent	2013.8.31–9.20	Up to 6	
Ontario	Rural	2010.3.30– 2011.3.29	4.71	Passive Sampler
Vredoped	Rural	2009.12.16– 2010.2.18	Up to 197.61	DOAS
Barcelona	Urban BC	2011.5.6–9.7	2.9 ± 1.3	On-line Instrument
Spain	Urban CC	2011.5.13–6.28	7.5 ± 2.8	

2.4 Factors increasing ammonia volatilization

There are many environmental factors that can trigger ammonia volatilization including high pH value and high temperature of the soil. High soil pH and high temperature of the soil increase accumulations of ammonia dissolved in soil water and warm soil water cannot sustain as much ammonia gas. Although a temporary increase in pH may result in significant volatilization loss from soils with an initial pH as low as 5.5, warm temperatures raise the rate of urea hydrolysis and ammonium conversion to ammonia gas, and consequently increase volatilization (Engel, Jones, & Wallander, 2011).

The volatilization of surface urea increases linearly with increasing soil water content, until the soil reaches saturation. 0.1 inch of rain or irrigation dissolves fertilizer allows volatilization to occur while 0.5 inch of rain or irrigation pushes dissolved fertilizers about 2 inches deep into the soil and stopped the volatilization from occur if it is done within 2 days from fertilization (Jones, Brown, Engel, Horneck, & Olson-Rutz, 2013).

Residues of crops left in the soil also increase the volatilization rate where the urease enzyme required for hydrolysis is produced by microorganisms that are 40 times more active in surface residues than in mineral soil. Besides, the residue of crops often exceeds the pH of the soil, which increases ammonia, impedes the movement of Nitrogen into the soil and also maintains soil moisture (Jones et al., 2013).

Volatile NH_3 losses from irrigation and floodwater can be substantial. High NH_3 concentration, high water pH, warm temperature and high wind speed all contribute to the probability of loss. Urea is more susceptible to volatilization when dispersed into flood water (such as flooded rice) than a fertilizer such as ammonium sulphate

since the pH is likely to rise as urea is hydrolysed to ammonium carbonate (Clain, Richard, Jason & Brad, 2007). Photosynthesis of plants and algae growing in water increases the pH of the water when flooded rice grows as CO₂ is depleted during the daytime, causing pH to rise to 9. CO₂ during plant respiration (forming carbonic acid) is released during the night and the water pH decreases again (Zhenghu & Xiao, 2000).

2.5 Ammonia volatilization problems to health and environment

2.5.1 Issues on environment

China has been the world's largest source of NH₃ emissions, which is why they have experienced extreme severe and persistent haziness in recent years and has caused death up to five life years averagely (Wu et al., 2016). NH₃ contributes significantly to the formation of secondary inorganic aerosols (SIA) resulting in alkaline gas pollution from the atmosphere. The finding shows that NH₃ emissions have a significant impact on the average monthly (mean daily concentration) PM_{2.5} (fine particles with aerodynamic diameters below or equal to 2.5µm), concentrations across major cities in China (Wu et al., 2016). They also suggested that NH₃ is the critical pollutant of PM_{2.5} nucleation - related acid - base reactions.

Atmospheric NH₃ also affects NH₄⁺ when the NH₃ deposits on plant surfaces, dissolves and is washed into the soil where it can increase soil acidity and interfere with basic cation absorption (Pearson & Stewart, 1993). Negative effects on vegetation occur through direct toxicity when absorption exceeds the capacity of detoxification and, via N build-up. Excess ammonia will contribute to increased nitrification and denitrification, greenhouse gas emissions and eutrophication (deprivation of oxygen).

2.5.2 Issues on health

The ammonia gas that has volatilized also affects humans. Accidental acute exposure to ammonia makes eye injuries the most common cause of permanent disability. At a concentration of 140 ppm, gas ammonia is slightly irritating to the human eye and immediately irritates at 700 ppm. While exposure to ammonia vapor of 40 ppm led to headache, nausea and decreased appetite. Mild ammonia gas exposure usually leads to temporary, irritating symptoms of the respiratory system. Dyspnea, wheezing, coughing, nasal discharge and bronchial secretions are immediate signs of accidental ammonia inhalation (Finis et al., 1989).

2.6 Methods for determining the volatilization of ammonia

There are many methods of determining ammonia volatilization in farmland includes direct method and indirect methods.

2.6.1 Direct methods

The direct methods are enclosure method where the soil, fertilizer and plants are enclosed together in an airtight container, and absorb the ammonia from the system by acid or alkaline substance, and then make quantitative determination. It is directly through the ammonia capture device to capture ammonia from the soil surface, commonly used in cell experiments, with advantages of simple equipment, easy to operate, good mobility, multi-point simultaneous measurement and spatial distribution measurement and high sensitivity (Song & Fan, 2003). But the ammonia in the sealed state of the process is completely different from the natural state.

Another direct method found was venting method where it was an improved version from enclosure method where it overcomes problem in the previous method. Compared with other methods, this method is simple, convenient combination, low sampling device was also made of polyvinyl chloride rigid plastic bucket (15 cm in diameter, 10 cm in height). Two sponges with a thickness of 2 cm and a diameter of 16 cm were uniformly impregnated with 15 mL of glycerol solution (50 mL of phosphoric acid + 40 mL of glycerol, constant volume to 1000 mL) and placed in a hard plastic bucket. The lower sponge is 5 cm from the bottom of the bucket and the upper sponge is flat with the top of the bucket. Upper sponges absorb ammonia in the air and prevent it from entering the lower sponge is absorbed within the device (Yang et al., 2018).

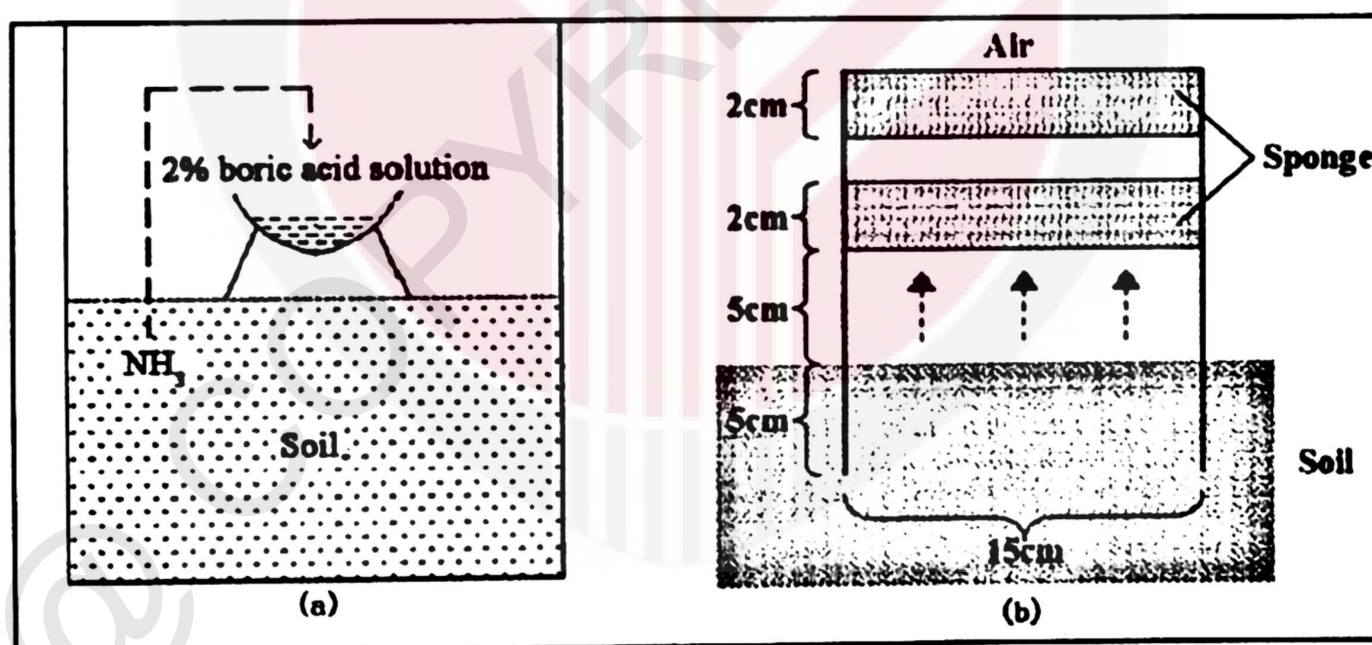

Figure 3 : Enclosure(a) and Venting(b) methods (Yang et al., 2018).

2.6.2 Wind tunnel method

For indirect method, there are wind tunnel method where the volatilized ammonia gas sample were measured by calculating the difference between inlet and outlet of Teflon pipe. The remaining gas is expelled by the air pump and the solution in the bottle is determined by colorimetric method. Finally, the ammonia volatilization per unit soil area at a given period of time was calculated by the difference between the outlet and the air inlet. However, this method requires expensive equipment.

The wind tunnel method achieves continuous automatic sampling. By adjusting the wind speed, so that the wind tunnel inside and outside the temperature, humidity, light and other factors remain consistent (Yang et al., 2018).

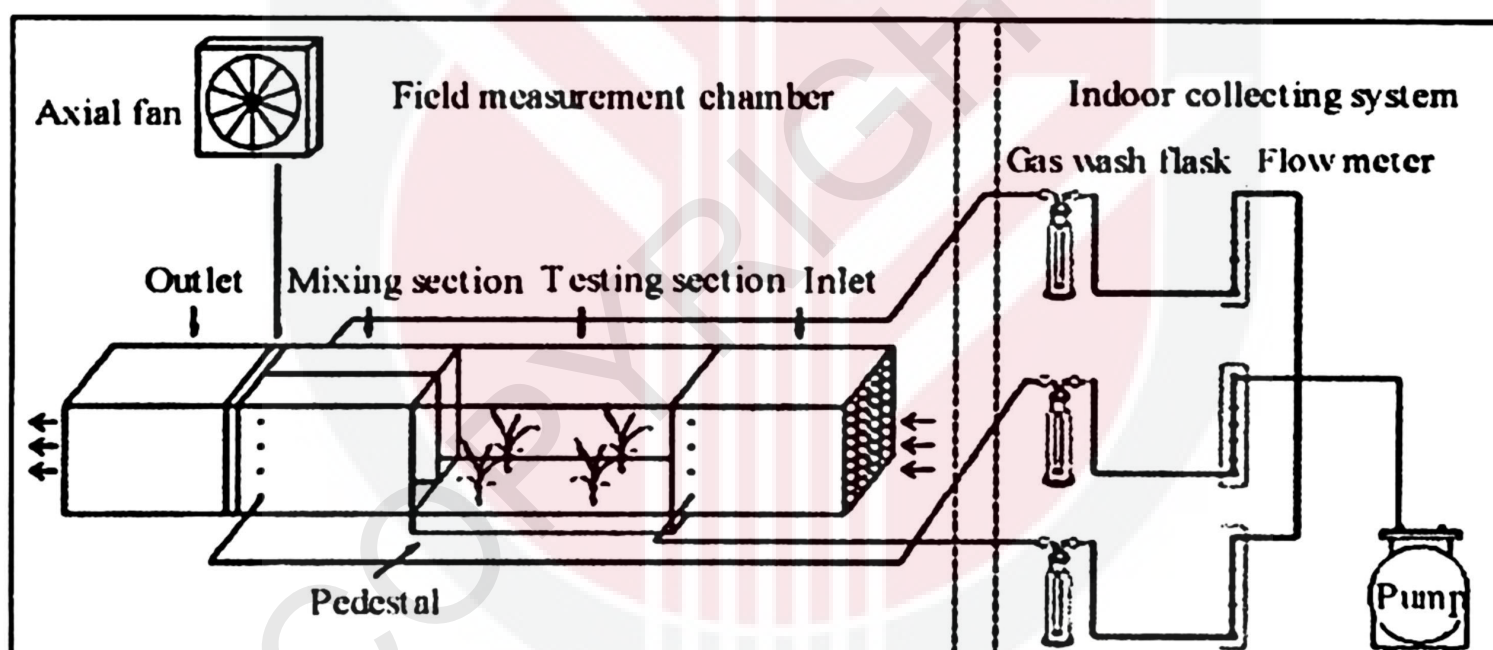

Figure 4 : Wind tunnel method for determination of ammonia volatilization (Yang et al., 2018)

2.6.3 Horizontal flux method

An integrated horizontal flux method was used to measure NH_3 volatilization. The samplers were fixed on the vertical direction, and could freely rotate with the main wind direction to ensure that the most amount of ammonia in this direction could enter the samplers.

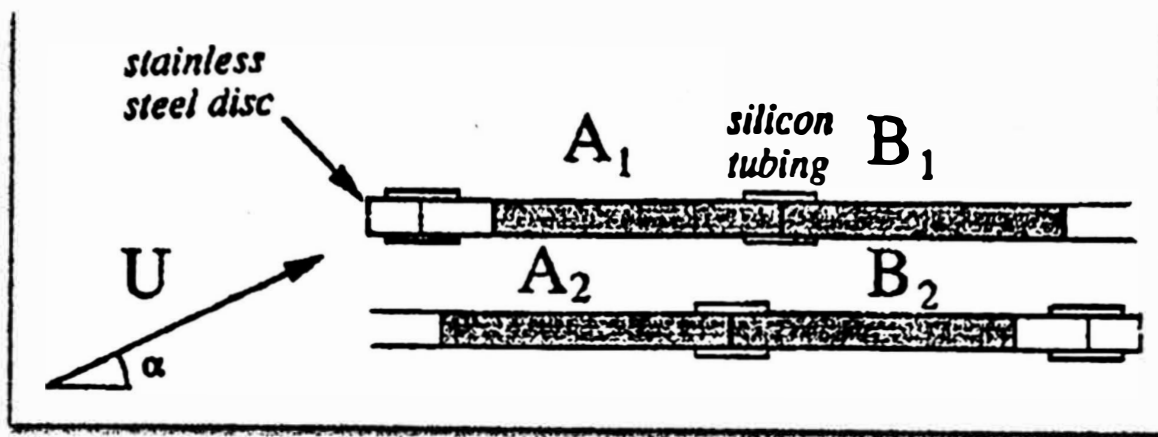

Figure 5 : Simple passive sampler

The sampler is made up of 2 glass vials, each 10 cm long and 0.7 cm in diameter. The two glass vials are connected to each other with silicon tubing and another pair are placed in series. Then, the sampler is placed at support pole at different heights to obtain different value of NH₃ emissions. A stainless steel disc with a hole was glued to the opening of sampler. The function of the stainless steel disc was to reduce the air velocity inside the pipes to obtain low friction force and maximum sampling effectiveness of NH₃. Oxalic acid are used to coat inside the glass vials (Schjoerring, Sommer, & Ferm, 1992).

Previous researchers (Thompson et al., 1990; Sommer et al., 1991) stated that there was a significant relationship between the NH₃ flux and the wind speed when the wind speed was lower than 2.5 m/s after slurry manure was applied. The result shows that in the daytime, the flux of ammonia volatilization was higher than that in the night time. This result indicates that the volatilization of NH₃ is positively related to the air temperature. Ammonia volatilization also occurs due to strong sunshine, high temperature, the use of high pH fertilizer, or sometimes, the unsuitable fertilizer and slurry application methods. In this experiment, the pH of the slurry was 7.84, and the slurry was only applied on the surface of the soil.

2.6.4 High-resolution measurement of ammonia emissions

The online measurement system consisted of three parts, including a wind tunnel system, a rotary gas collector (RGC) system and an ion chromatography. The wind tunnel system was used to simulate a real cultivation environment, which automatically sampled the airflow and kept the inside and outside micro-meteorological factors (e.g. sunlight, temperature, wind, and soil) basically the same (Braschkat et al., 1993; Mannheim et al., 1994; Huang et al., 2006).

In the RGC system, NH_3 was absorbed and converted to ammonium by a chemical reaction with methane sulfonic acid. The RGC system was exploited to continuously collect gas online with high collection efficiency (Dong and Zeng, 2007). RGC System components included a worktable, sampling pipes, a rotary wet diffusion tube, flow controllers, inlet and outlet devices, analytical devices, and a power pump. The inlet of the diffusion tube was connected to the sampling pipe, while its outlet was attached to the flow controller; the outlet of the flow controller was connected to the pump. The samples were then transferred to glass bottles and analysed by an ICS-900 (Dionex Corp., Sunnyvale, CA, USA) which was equipped with a CSRS 300 column (4 mm) for analysis of cations. The time resolution of the on-line measurement system was set at 30 min. The online NH_3 emission monitoring system was proved to be stable and accurate in the current studies.

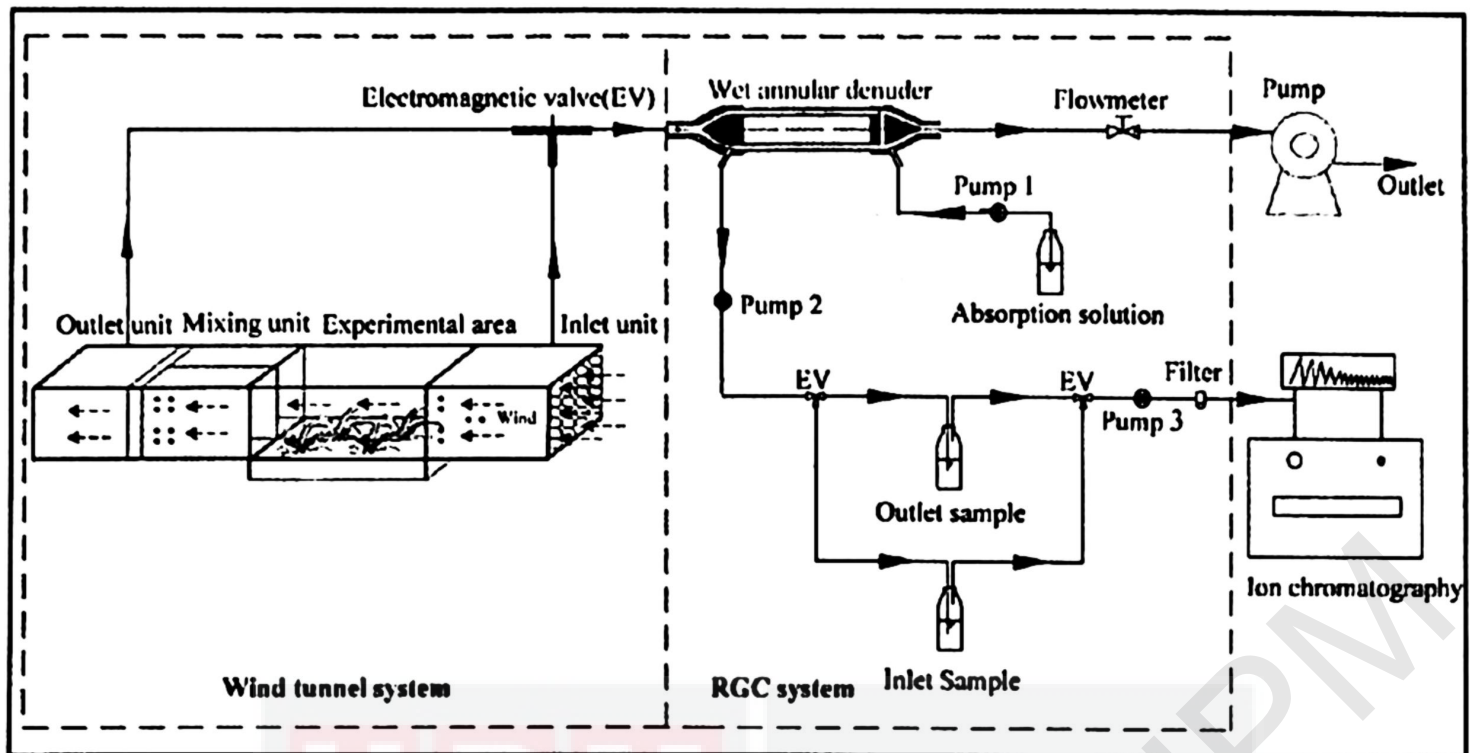

Figure 6 : Diagram of the ammonia emission on-line measurement system (Gong et al., 2013)

2.7 Summary

The micrometeorological method is chosen in this study because it directly samples the air above the land, and does not change the natural environment, so it does not interfere with the ammonia volatilization process. This method overcomes the shortcomings of the above methods which cannot accurately quantify ammonia volatilization, especially in the monitoring of ammonia volatilization in large areas like paddy fields, and the above methods are usually used for calibrating other methods.

CHAPTER 3

MATERIALS AND METHOD

3.1 Study Procedure

This study's main focus is to study and compare the existing methods for measuring ammonia volatilization, to design a device for sampling ammonia gas in the air above flooded rice system and to fabricate the designed device. The first step is to study existing methods and devices for measuring ammonia volatilization and to compare the methods' advantages and disadvantages. The second is designing a cheap and suitable method for measuring ammonia volatilization and the third step is the development and evaluation by experiments of the designed methods.

At the beginning of this study, there are several methods of collecting ammonia gas in the air which are enclosure and micrometeorological method. The meteorological method was chosen for this study, where in free air above the surface of floodwater in rice fields, the vertical flux density of the gas is measured. Micrometeorological method was chosen because it tests the air above the surface of flood water and does not alter the natural environment, thus, it does not disrupt the mechanism of ammonia volatilization.

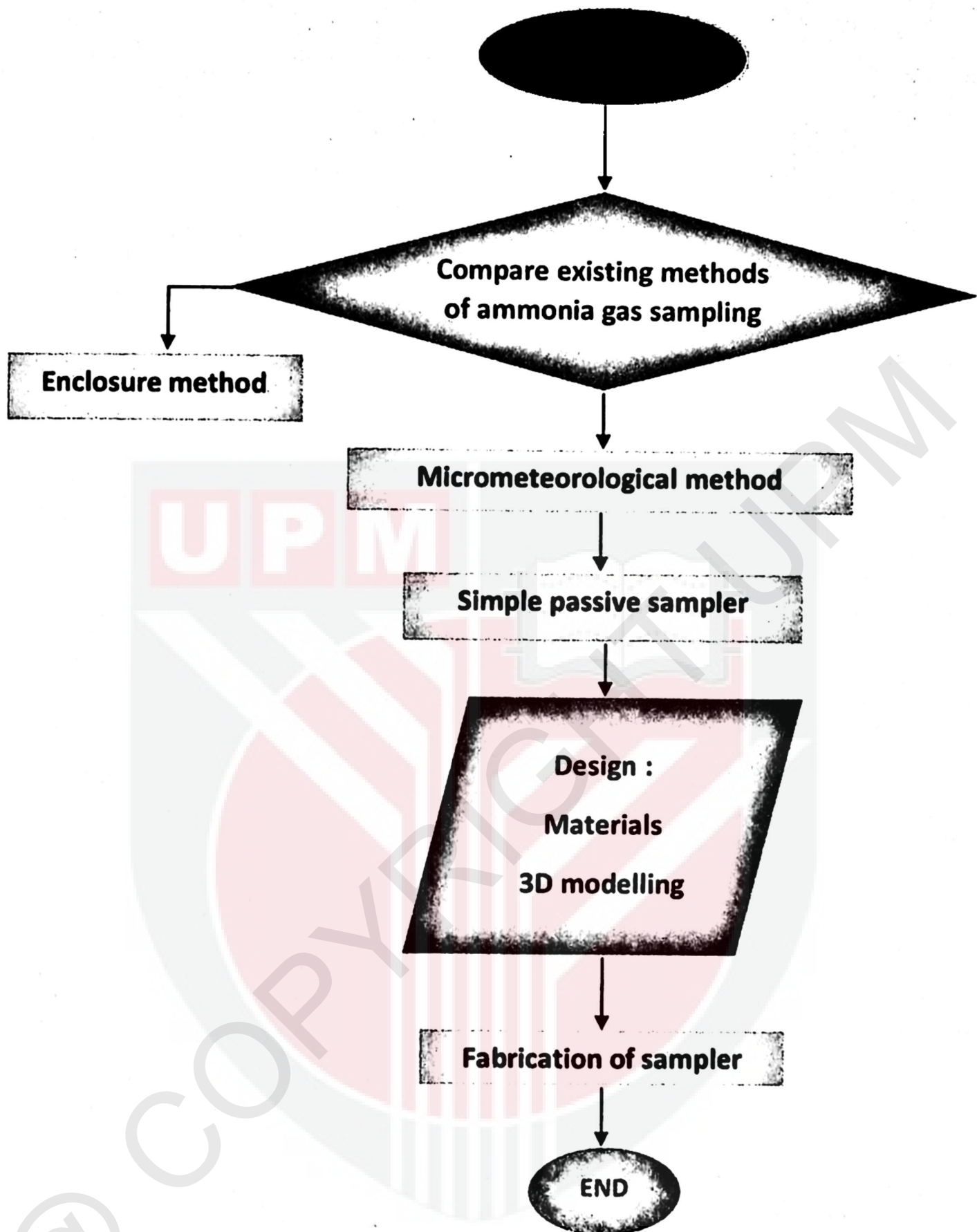

Figure 7 : Procedure of designing ammonia gas sampler device

3.2 Available micrometeorological sampler for gas collecting

3.2.1 Zurcher passive sampler

Zurcher sampler is a polypropylene vessel on the upper side with a lid and a Teflon gasket and an outlet on the lower side. The 0.2 mm thick Teflon membrane is positioned 7 mm underneath the tube edge. It isolates the surrounding air from strongly diluted HCl solution as absorption liquid. A custom protection box was built at the passive sampler's entrance to overcome air turbulence (Thöni, Seitler, Blatter, & Neftel, 2003).

The box comprises of an internal cylinder, opening at the base, enclosed by a closed container, at the top of the side wall with 21 air vents (diameter 9 mm) and seven at the bottom.

Ammonia disperses into an acid absorption solution via a permeable membrane. The primary advantages are: first, due to the absorption of ammonium-containing gases, it eliminates as much interference as possible, and second, it prevents the extraction phase of the covered surfaces in the samplers.

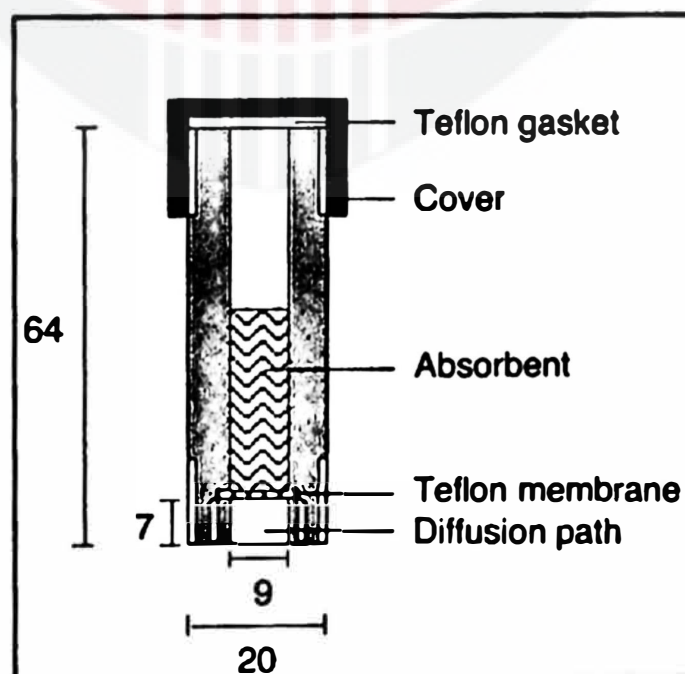

Figure 8 : Zurcher sampler with dimensions in mm

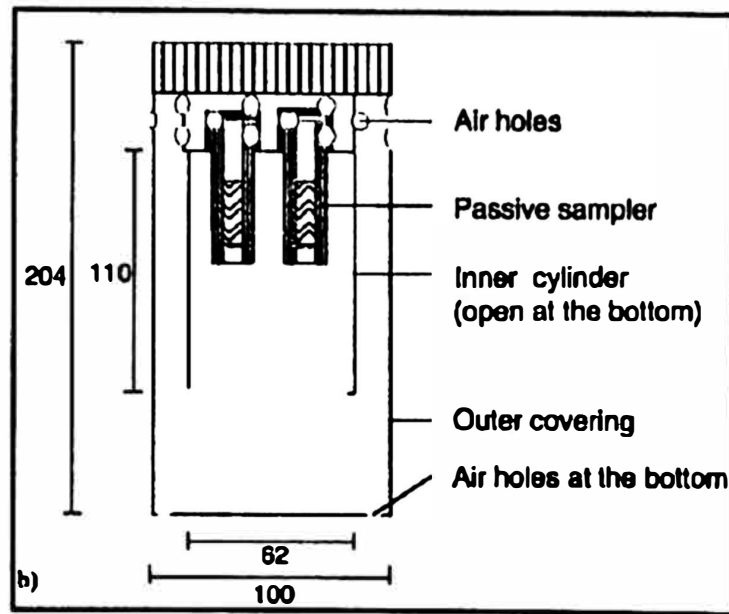

Figure 9 : Custom protection box for Zurcher sampler

3.2.2 Leuning ammonia sampler

This Leuning sampler is a collection device that point into the wind and completely remove the NH_3 contents from the airstream that enters the device at the front and leaves it through an orifice at the rear. It comprises of an entry nozzle, an exterior cylinder equipped with pivots and fins to maintain the equipment parallel with the wind and a Venturi cover that supports a thin stainless steel orifice plate. Stainless steel was used to build inner absorbing structures consisting of a spiral of thin layer coiled on two wire retainers connected to a core steel tube.

As the airstream impacts on these coated surfaces, the NH_3 molecules react with the oxalic acid, forming $(\text{NH}_4)_2\text{C}_2\text{O}_4$ (ammonium oxalate) crystals. At the end of the collection period, these, together with any excess oxalic acid, must be washed off the surfaces and analyzed for NH_4^+ concentration (Yao & Zhang, 2013).

Oxalic acid has been selected as the absorbent for ammonia since Ferm (1979) proved that ammonia gas could be fully absorbed by oxalic acid coatings at all relative air flow, humidity and that differences in temperature are not anticipated to impact the effectiveness of absorption.

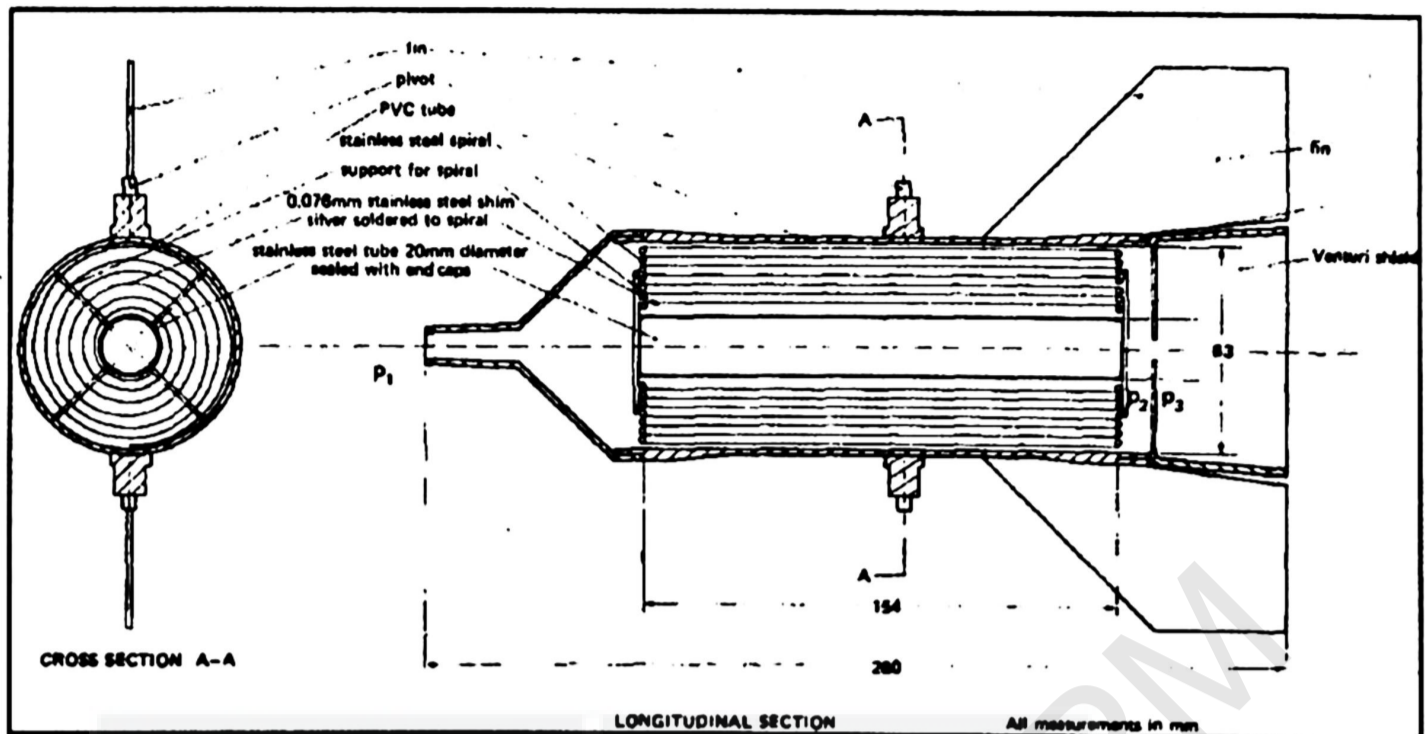

Figure 10 : Leuning sampler schematic diagram (R. Leuning, J. R. Freney, 1985)

3.2.3 Ogawa sampler

The passive Ogawa sampler made by Ogawa USA, Pompano Beach, Florida is a handy tool for inspecting concentrations of atmospheric ammonia gas. The sampler consists of an air inlet on both side of a plastic casing. More than one gas can be sampled at once, as the two inlets are separated by the body's solid segment.

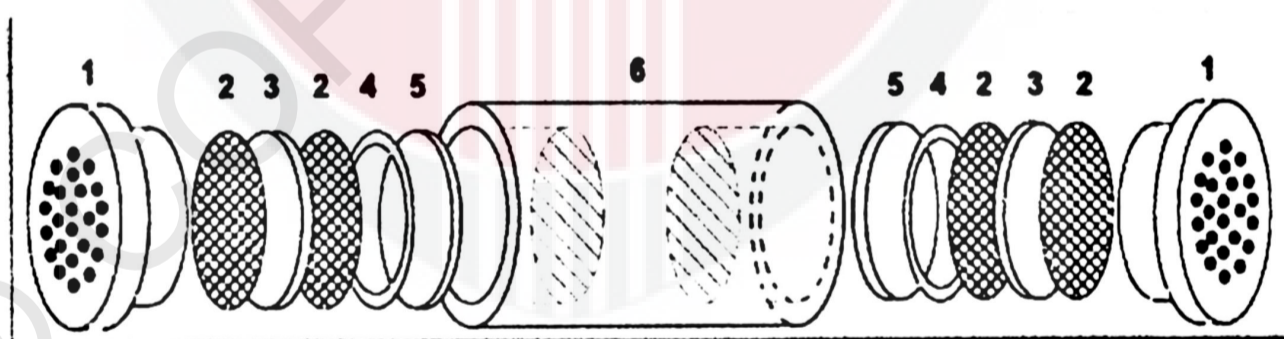

Figure 11 : Ogawa sampler (Roadman et al., 2003)

In the Ogawa sampler, from (1) is the end cap, (2) stainless steel screen sandwiching (3) filter made of glass fiber to gauze impurities, (4) retainer ring and (5) base pad. In its double-inlet setup made of Teflon with 2 cm outer diameter and 3 cm length, the sampler comprises two gas collection pads. The pads have a diameter of 14.5 mm and are specifically coated with a selected gas according to the type of gas needed to be sampled. To determine ammonia gas, the pads are soaked into citric acid solutions.

Commercially available Ogawa passive samplers were used to monitor NH_3 in the high concentration areas of the network during the warm months; slightly larger custom designed passive samplers were used to monitor NH_3 in the low concentration areas and throughout the winter period (Yao & Zhang, 2013).

CHAPTER 4

RESULTS AND DISCUSSION

4.1 Results

4.1.1 Design of sampler

During this study, the design of readily available methods for determining ammonia volatilization are being analysed. Sampler from R. Leuning will be used as an example and comparison. The sampler performance has theoretically predicted and tested in wind tunnel, laboratory and also in field. The results shown that the air flow through the sampler is directly proportional to air flow externally and the ammonia that has absorbed by the sampler can be determined quantitatively.

4.1.2 Conceptual design

The sampler works with inner oxalic acid coating to catch any ammonia in the atmosphere that flows through the sampler. This sampler has been fitted with nozzles and fins to maintain it always upwind.



Figure 12 : 3D drawing of sampler

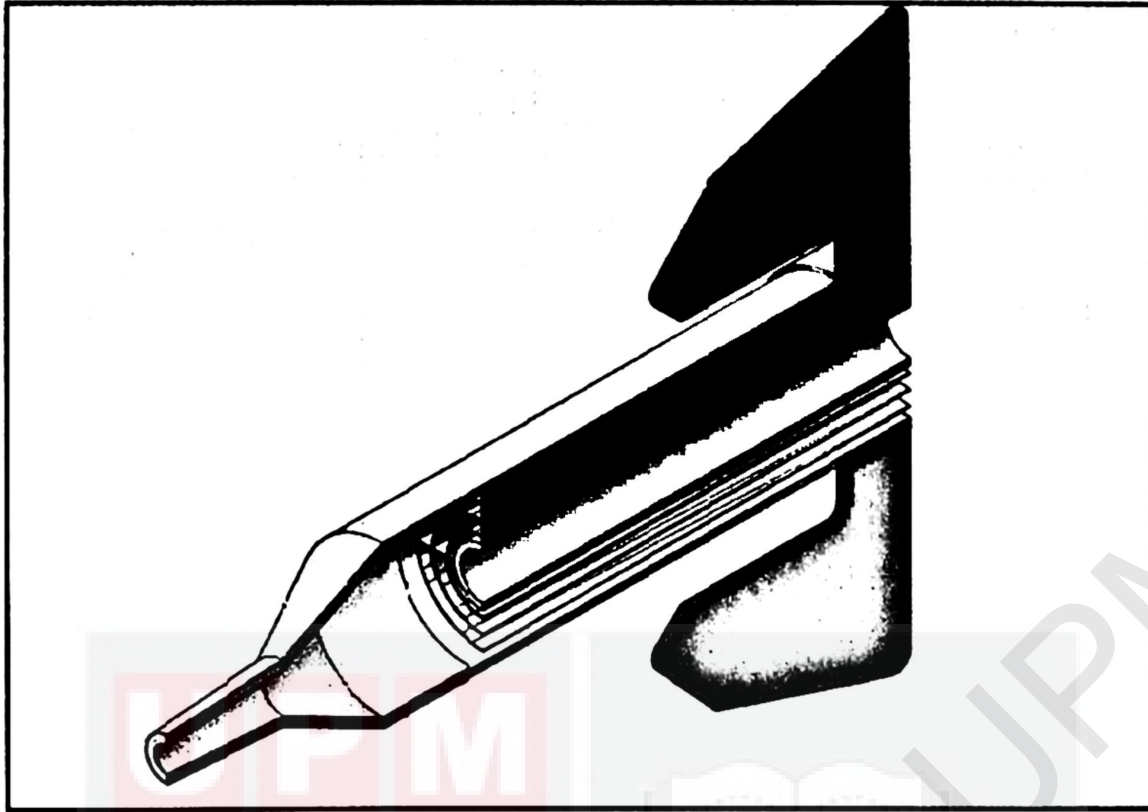

Figure 13 : Sectional drawing of the sampler



Figure 14 : Fabricated sampler



Figure 15 : Stainless steel assemble inside sampler body

The air enter nozzle at high speed and flows into the sampler. At the beginning, the air flows in turbulence. The nozzle decreases air speed inside the tubes to achieve a high NH_3 collection efficiency. At the stainless steel assembly, air flow perpendicularly until it exits at the end of the sampler body. The fin is fitted to the sampler body to guide it along with the wind directions.

For ease of handling, the fins to align the sampler with the wind direction is mounted on the body of sampler. It is detachable to ease the process of coating oxalic acid and handling in the laboratory.

4.1.3 Materials

Stainless steel was used to construct the inner surfaces of sampler. The inner surface of the sampler acts as absorbent surface for NH_3 gas. Oxalic acid is going to be used to coat the surfaces and stainless steel can withstand the chemical.

To cut the stainless steel shim into parts, a stainless steel scissors are used. As the sheets are so thin, it is not possible to use other tools in the workshop because of lack of tools specified for stainless steel fabrications. Before cutting, careful and precise measurements are done on a flat surface using L-square and steel ruler. Each of four supporting stainless steel shim with thickness of 0.1mm are cut into 13.5mm x 150mm. Meanwhile for the rings, the diameter are 25mm, 35mm and 45mm each. The circumference for each of the rings are 78.54mm, 109.96mm and 141.37mm.



Figure 16 : Stainless steel shim 0.05 mm and 0.1 mm

PVC material is chosen as the sampler body because it is a great low-cost mechanical and chemical resistance characteristics. The workability of PVC with oxalic acid is good at both low (20°C) and high (60°C) temperature (“Chemical Resistance Guide,” 2003).

Epoxy has a good resistance towards oxalic acid. The electrical, thermal and chemical strength of epoxy resin is exceptional. Epoxy resilience with fibrous reinforcement or mineral fillers is commonly increased. In this design, Hardex 3 ton Steelweld epoxy compound hardener & resin is used to fasten the stainless steel shims together with the rod. The parts are joined together and held for 30 minutes before it dries up strongly. The supporting 0.1mm shims are glued perpendicularly to the steel rod. After it has completely dried, the rings of 25mm, 35mm, and 45mm are glued onto the supporting shim with 10mm gap from each other.

Other methods of joining have been tested such as MIG welding and soldering, are not suitable because the method needs two parts that is going to be joined together, melted. This is because the stainless steel shim is really thin and not possible to melt before it is joined together.



Figure 17 : Epoxy resin and hardener

3D printing is used to create the fin and nozzle of the sampler. The material for both parts are Acrylonitrile Butadiene Styrene (ABS). ABS material has excellent physical characteristics, such as good tensile resistance and rigidity where the material are usually used to make car bumpers and LEGO products. It is also have a high resistance towards heat and chemical. ABS also have proven has an excellent resistance to oxalic acid (“Acrylonitrile-butadiene-styrene (RAU-ABS),” 2013)



Figure 18 : Process of making fin and the fittings

After making 3D drawing in the AutoCAD, 3D printer are used to create a 3D model of fin and funnel. 3D printer used in this study is Flashforge Creator Pro model. At the earlier stage of printing process, an HDPE plate was used as the construct platform to ensure the bottom layer adhesion. In this process, the object is created by laying down successive layers of ABS material until the object is created. Each of these layers can be seen as a thinly sliced horizontal cross-section of the eventual object. The nozzle in the printer is heated to melt the material and can be moved in

both horizontal and vertical directions by a numerically controlled mechanism, directly controlled by a computer-aided manufacturing (CAM) software package

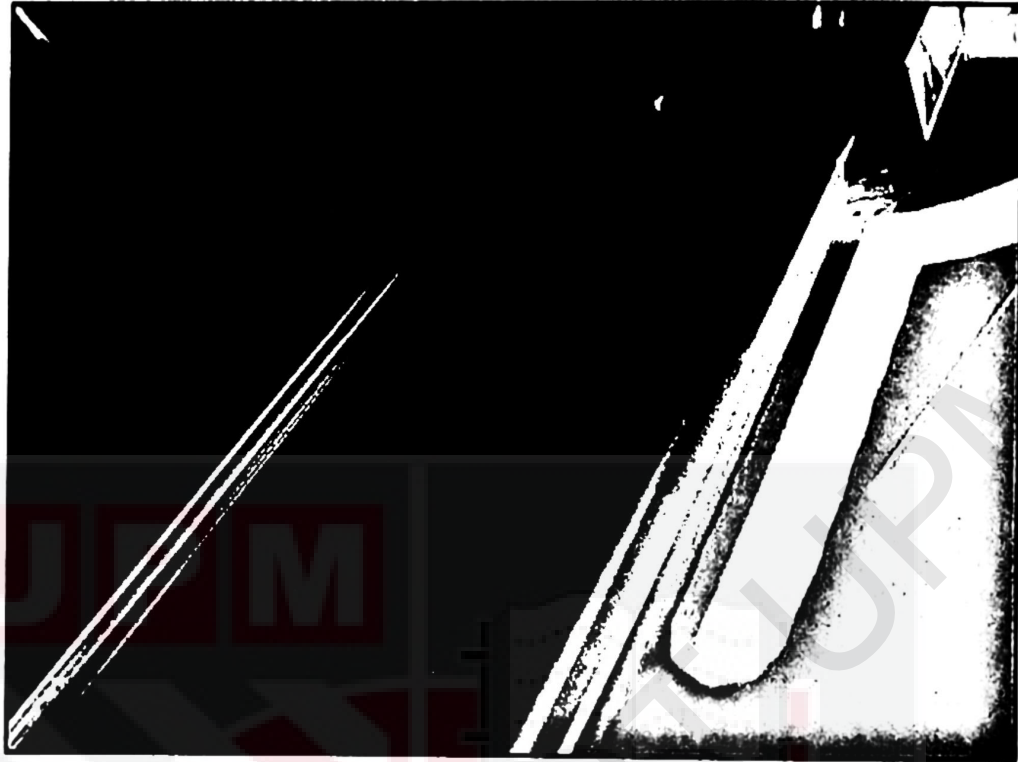

Figure 19 : Early stage of printing process

4.1.4 Dimensions of sampler

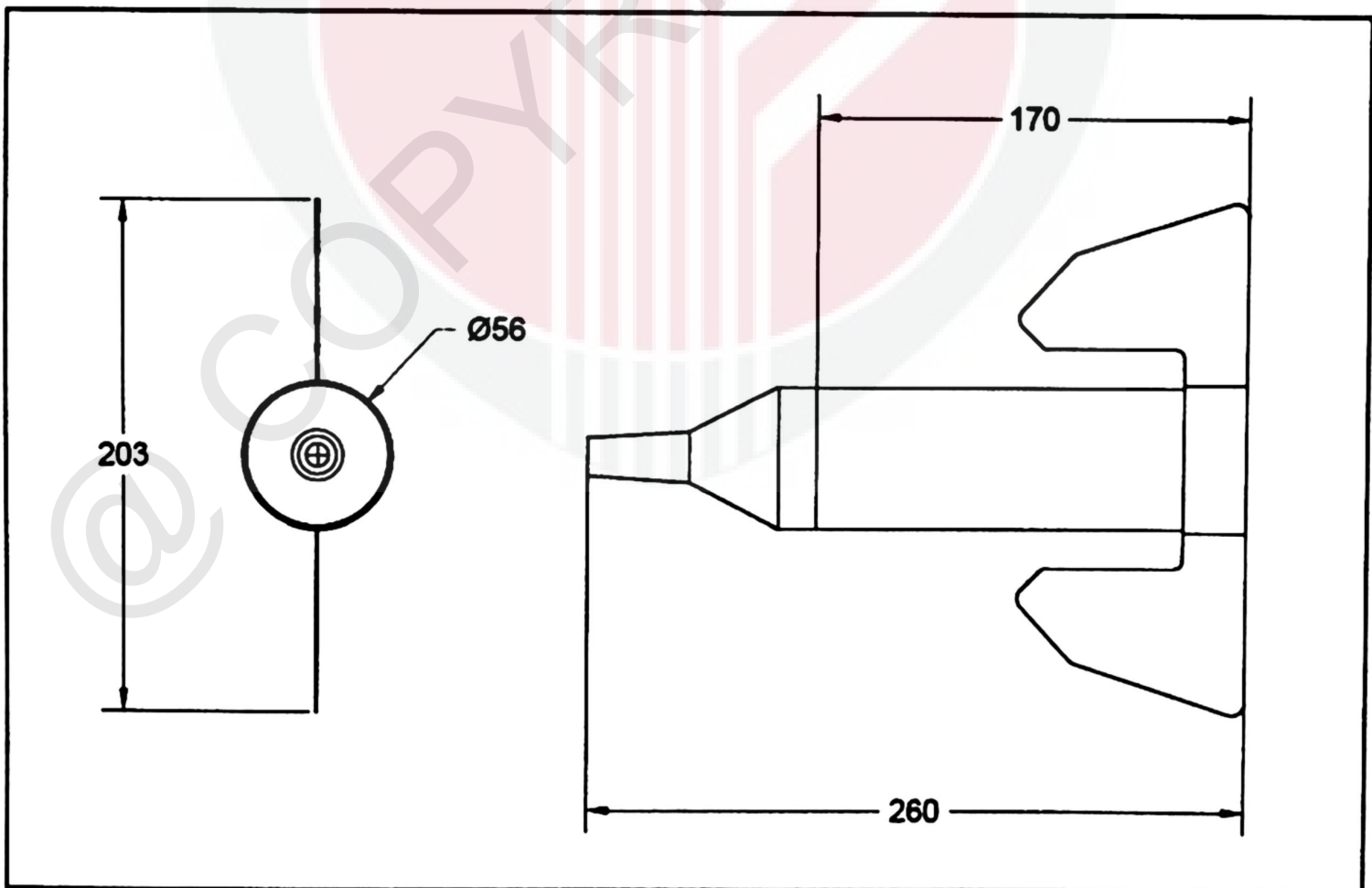

Figure 20 : Dimensions of sampler (in mm)

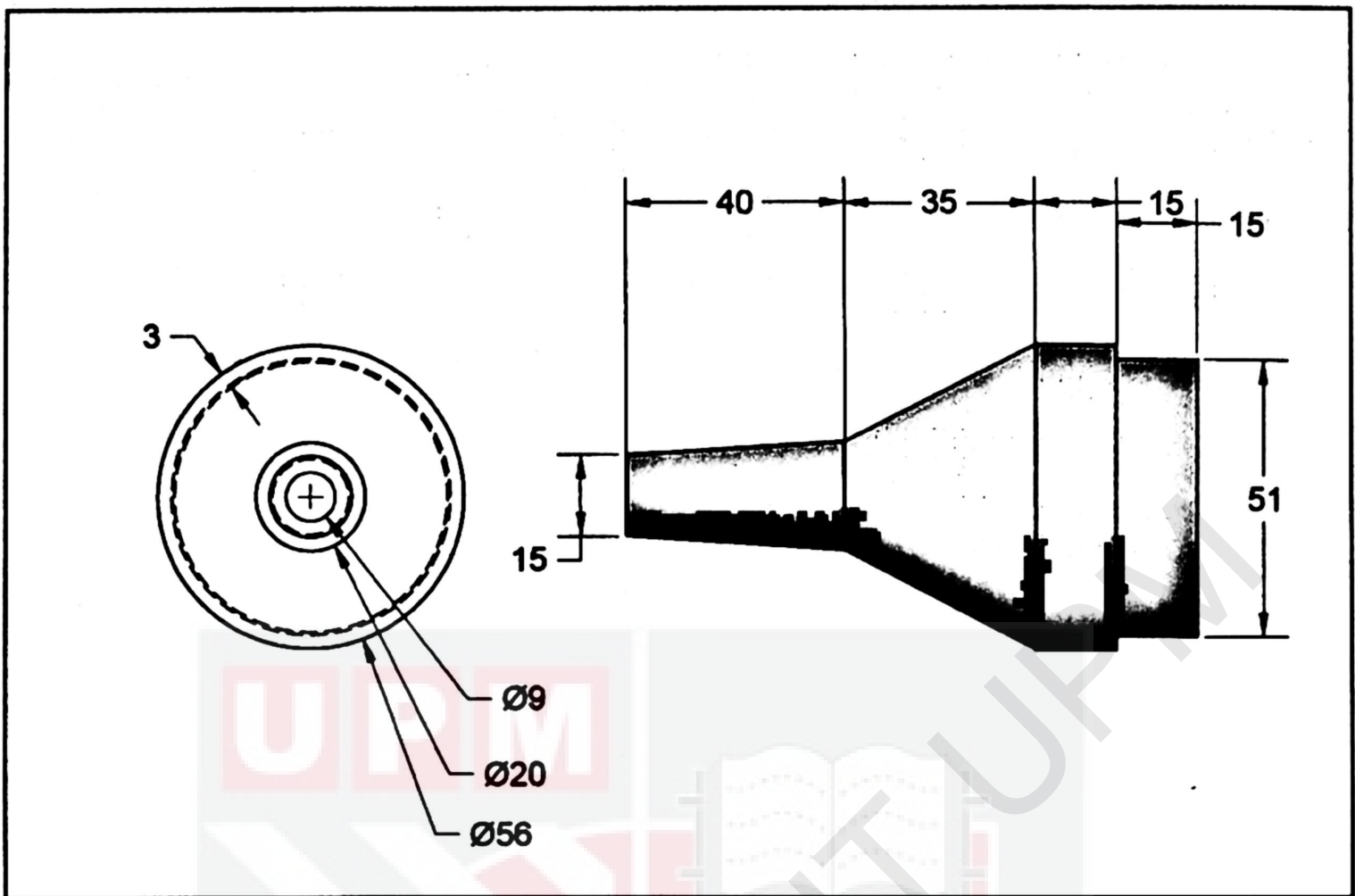

Figure 21 : Dimensions of funnel (in mm)

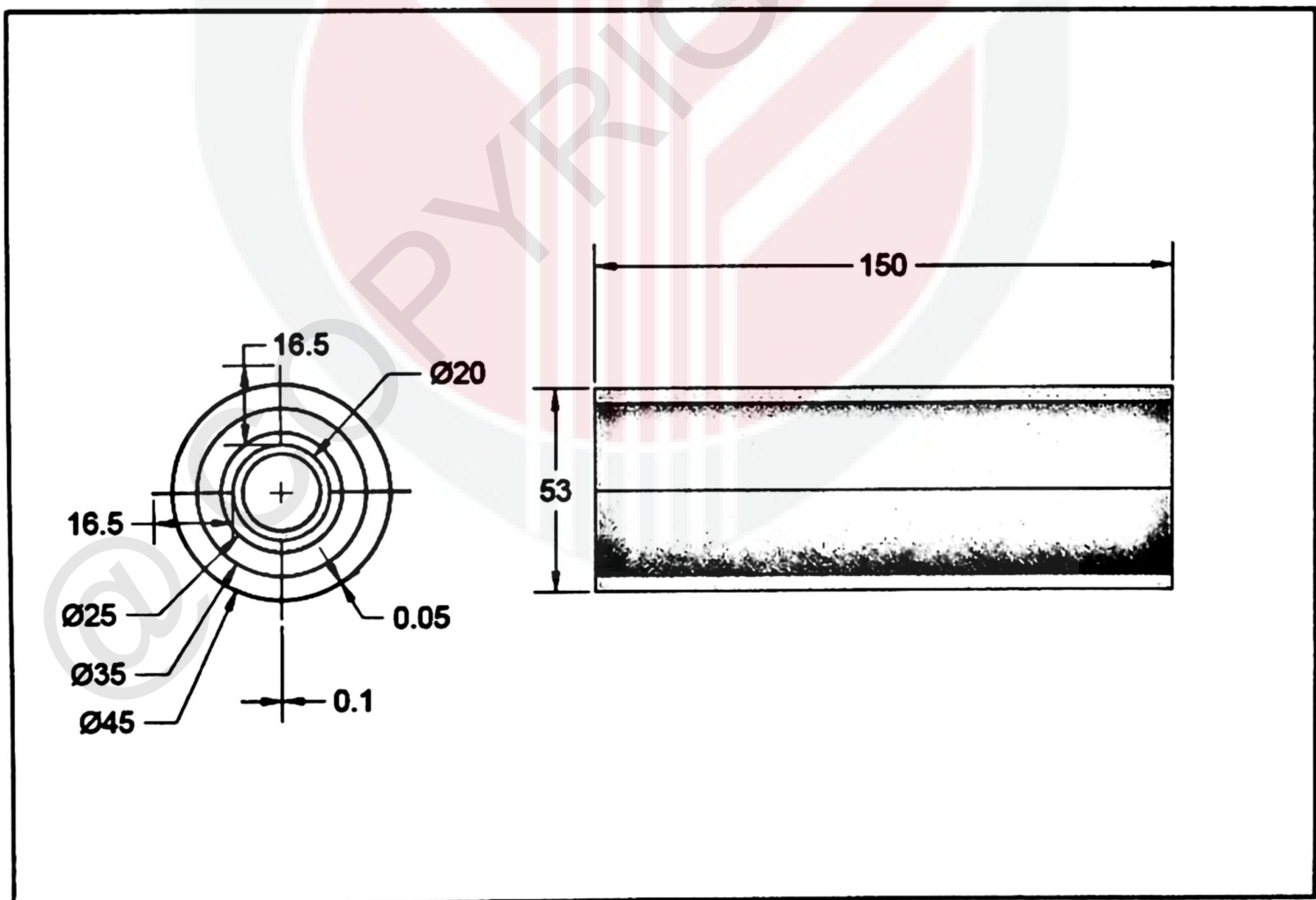

Figure 22 : Dimensions of stainless steel assembly (in mm)

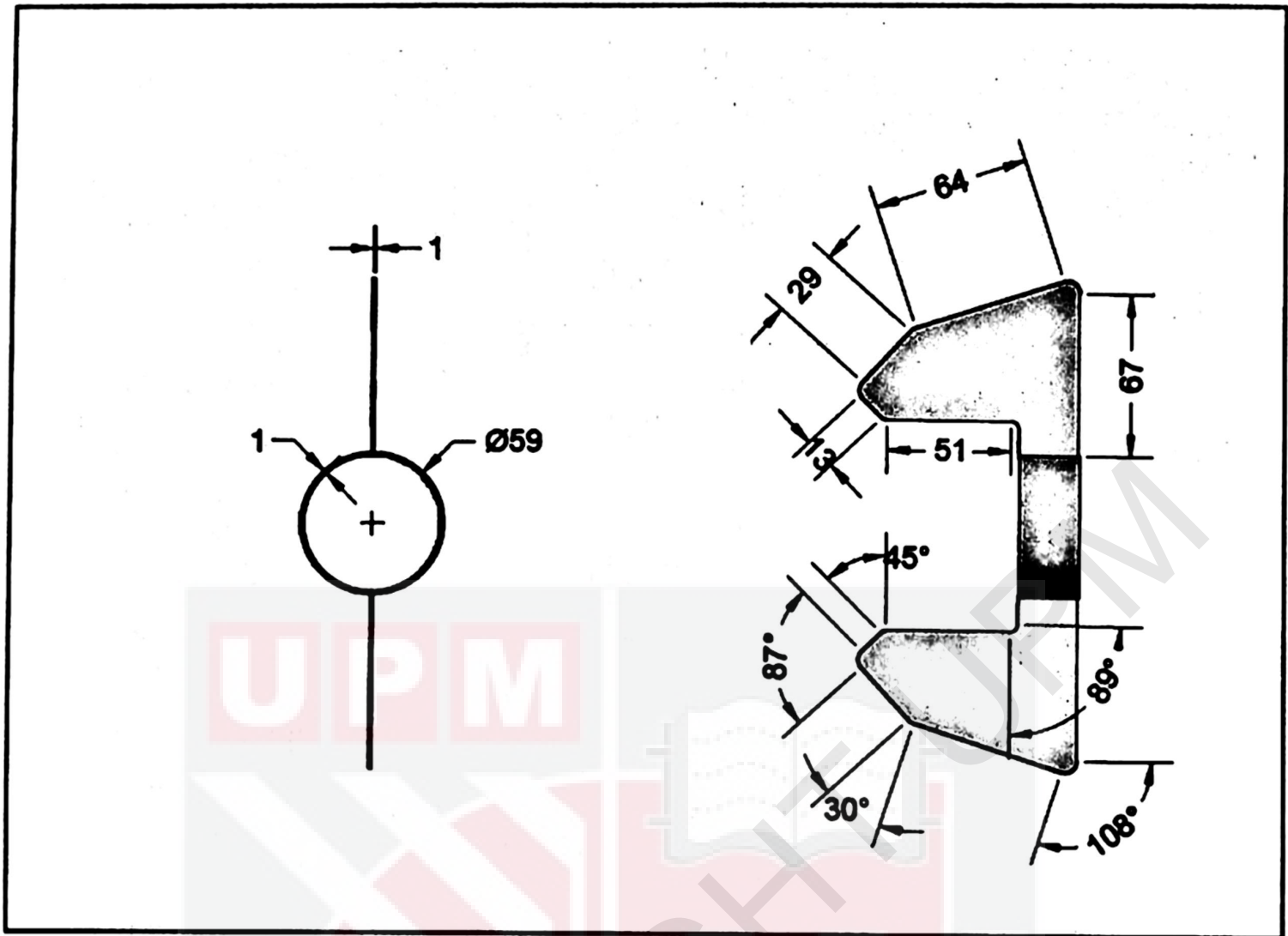

Figure 23 : Dimensions for fin (in mm)

The outer part of the sampler that is made of PVC are 170 mm long, 56 mm diameter. After funnel is attached, the total length of the sampler is 260 mm. The opening of the funnel is 15 mm in diameter.

Meanwhile for the stainless steel assembly, the core rod have 20 mm diameter, coiled with 25 mm, 35 mm and 45 mm of stainless steel shim glued along four stainless steel shim (16.5mm length each) attached on the surface of the rod.

4.1.5 Cost

Table 4 : List of items and price per unit.

Description	Quantity	Cost
RS Pro Stainless Steel Rod (300mm length, 20mm dia.)	1	MYR 77.99/unit
RS Pro Red Steel Shim (1.25m x 150mm x 0.1mm)	1	MYR 392.61/unit
RS Pro Red Steel Shim (1.25m x 150mm x 0.05mm)	1	MYR 323.51/unit
PVC pipe	1	MYR 9.00/meter
TOTAL		MYR 803.11

Since the fabrication used half of the stainless steel rod and stainless steel shim, the overall cost will be divided by two. So, the cost for stainless steel items used is MYR 399.05. PVC pipe that is used is 170mm, so cost for PVC pipe for the sampler outer body is MYR 1.53. Meanwhile for 3D printing, the Flashforge printer is readily available in the department. The cost for printing by using ABS material is as below :

Table 5 : Costing for 3D printing.

Item	Quantity	Cost
Funnel	1	MYR 3.10
Fin	1	MYR 1.90
TOTAL		MYR 5.00

Table 6 : Total material cost for a unit of sampler

Items	Cost
Stainless steel assembly	MYR 399.05
PVC	MYR 1.53
3D printing	MYR 5.00
TOTAL COST	MYR 405.58

4.2 Discussions

4.2.1 Fabrication difficulties encountered

Since the assembly of this ammonia gas sampler are done by hand fabrication, there are many difficulties and problem encountered.

Stainless steel is an alloy with mixture of metals and other elements. It is typically considered stainless when the base is made from iron and the chromium content by weight is higher than 12% (Mackey, Seacord, & Lamb, 2013). In this study, stainless steel is the main material used to trap the ammonia gas.

At the beginning of fabrication of the stainless steel, there are few methods that have been tried to join them together. Metal inert gas (MIG) welding is one of the methods tried but it is not possible as the shim are too thin and easily perforated. Even with folding the shim to 2 and 3 layers, it is still not possible to do the assembly. When there is hole or pit on stainless steel shim surface, it can make the material corrodes. Stainless steel that is exposed to welding spatter and grinding dust can corrodes too, so careful finishing has been made to protect the material from cross contaminate from other types of metal.

As stainless steel has the least machinability (*Stainless Steel - Design Considerations*, 2002) due to lack of suitable machine availability, process of cutting stainless steel shim can be quite hard as these thin sheets experienced buckling.

When doing hand fabrication of small parts, there are some limitations to it. In this study, there are limitations of making the spiral shape for stainless steel shims. So, to simplify the process, three rings of stainless steel shims of different diameter are used. The distance between rings are 10mm each. It is the most suitable and constructible for hand fabrication.

4.2.3 Advantages and disadvantages of sampler

This sampler is very simple to use, in contrast to techniques which require anemometers, pumps, flow meters and electrical power. It can be used for sampling other types of gas as well by changing the type of chemical for trapping different types of gas emissions.

Despite of the advantages, this sampler requires a large and flat test area to do overall testing for the whole area of paddy field. To test the sample of ammonia gas collected can be quite complex because it requires expensive measuring instruments to measure the amount of ammonia gas collected in the sampler. The ammonium (NH_4^+) concentration in the extract solution was measured with an ion-specific electrode (ISE-10-10-00, HNU Systems, Newton, MA, USA) (Laubach, Taghizadeh-Toosi, Sherlock, & Kelliher, 2012).

4.2.4 Limitations

As mentioned earlier in the objectives which is the last objective is to fabricate the designed gas sampler, this design has not been tested for its performance. Laboratory testing should be done to determine the capacity of ammonia gas capturing in a controlled system.

4.2.5 Improving the sampler

In this study, the overall size of sampler are designed nearly as close as Leuning sampler. All of the fittings for funnel and fin to the body of sampler are carefully measured and fabricated so that it can be attached and detached easily, without using screws. All of the drawings made in the AutoCAD also should be measured and determined precisely so when it is printed, it can fit the sampler body. A modified sampler design will be needed if measurements are needed very close to the surface of water of flooded rice field.

CHAPTER 5

CONCLUSION AND RECOMMENDATIONS

5.1 Conclusion

The sampler has the practical advantages of being simple and easy to deploy, no climate parameters need to be quantified, no electricity is required, and the experimental area's surroundings are not specifically restricted. The loss of ammonia can be effectively and inexpensively assessed without the need for a big workforce.

With the design of ammonia gas sampler, ammonia losses in flooded rice systems can be analysed. It can be further controlled by suitable methods such as stabilizing the pH of floodwater, placing fertilizers at the right time of the day, using slow release fertilizers and deep placement of fertilizers instead of surface application.

Last but not least, improving ammonia gas management in flooded rice system production could result in both economic benefits to the farmer and environmental benefits to the watershed.

5.2 Recommendations

The recommendations that can be suggested for this study in the future is the researcher needs to set up a laboratory testing to determine this device's efficiency in trapping ammonia gas. Since this sampler should be deployed above the surface of flooded rice system, a set up consisting of paddy plants with irrigation system and water basin should be done to mimic the real conditions in paddy field. The inner part of the sampler also needs to be reviewed to increase the surface area and choosing materials that can keep it light-weighted so that the sampler can always be in the direction of wind.

REFERENCES

- Acrylonitrile-butadiene-styrene (RAU-ABS). (2013). *Material Data Sheet AV0270*, 8. Retrieved from <https://www.rehau.com/>
- Braschkat, J., Mannheim, T., Horlacher, D., Marschner, H., 1993. Measurement of ammonia emissions after liquid manure application. *Construction of a wind tunnel system for measurements under field conditions*, 156 (5), 393e396
- Chauhan, B. S., Jabran, K., & Mahajan, G. (2017). Rice Production Worldwide. In *Rice Production Worldwide*.
- Chemical Resistance Guide. (2003). *Metal Finishing*, 96(10), 72. [https://doi.org/10.1016/s0026-0576\(98\)80804-0](https://doi.org/10.1016/s0026-0576(98)80804-0)
- Choudhury, A., & Kennedy, I. R. (2005). *Nitrogen Fertilizer Losses from Rice Soils and Control of Environmental Pollution Problems Nitrogen Fertilizer Losses from Rice Soils and Control of Environmental Pollution Problems*. (December 2014).
- Clain A. Jones, Richard T. Koenig, Jason W. Ellsworth, Brad D. Brown, G. D. J. (2007). *Management of Urea Fertilizers to minimize volatilization*. (January 2007), 1–12.
- Engel, R., & Jones, C. (n.d.). *Ammonia volatilization from surface urea applications to wheat*.
- Engel, R., Jones, C. & Wallander, R. (2011). Ammonia volatilization from urea and mitigation by NBPT following surface application to cold soils. *Soil Science Society of America Journal*. 75:2348-2357.
- Finis, C., Nicolas P., H., Dana, C., Cyrus, H., Lawrence, K., & Leonard, K. (1989). *Summary Review of Health Effects Associated with Ammonia*. U.S. Environmental Protection Agency.
- Gong, W., Zhang, Y., Huang, X., & Luan, S. (2013). High-resolution measurement of ammonia emissions from fertilization of vegetable and rice crops in the Pearl River Delta Region, China. *Atmospheric Environment*, 65, 1–10.
- Jones, C., Brown, B. D., Engel, R., Horneck, D., & Olson-Rutz, K. (2013). *Nitrogen Fertilizer Volatilization*. (February). Retrieved from http://landresources.montana.edu/soilfertility/documents/PDF/pub/Urea_vol_factors_BMP_combo.pdf
- Jones, C. (2017). Ammonia Volatilization: Process, Amounts, and Effects on Yield and Protein. *Montana State University*, (April).

- Klimont, Z., Cofala, J., Schopp, W., Amann, M., Streets, D.G., Ichikawa, Y., Fujita, S., 2001. Projections of SO₂, NO_x, NH₃ and VOC emissions in East Asia up to 2030. *Water Air Soil Pollut.* 130, 193e198
- Laubach, J., Taghizadeh-Toosi, A., Sherlock, R. R., & Kelliher, F. M. (2012). Measuring and modelling ammonia emissions from a regular pattern of cattle urine patches. *Agricultural and Forest Meteorology*, 156, 1–17.
- Li, Y., Huang, L., Zhang, H., Wang, M., & Liang, Z. (2017). Assessment of ammonia volatilization losses and nitrogen utilization during the rice growing season in alkaline salt-affected soils. *Sustainability (Switzerland)*, 9(1).
- Lin, Z. cheng, Dai, Q. gen, Ye, S. chao, Wu, F. guan, Jia, Y. shu, Chen, J. dou, Wei, H. yan. (2012). Effects of Nitrogen Application Levels on Ammonia Volatilization and Nitrogen Utilization during Rice Growing Season. *Rice Science*, 19(2), 125–134.
- Mackey, E., Seacord, T., & Lamb, S. (2013). Stainless Steel: How Problems Arise and How to Avoid Them. *Opflow*, 39(11), 20–23.
- Miola E C, Rochette P, Chantigny M H, et al. 2014 J. Ammonia volatilization after surface application of laying-hen and broiler-chicken manures. *J Environ Qual.* 43 1864.
- Omar, S. C., Shaharudin, A., & Tumin, S. A. (2019). *The Status of the Paddy and Rice Industry in Malaysia*. Retrieved from http://www.krinstitute.org/assets/contentMS/img/template/editor/20190409_RiceReport_Full Report_Final.pdf
- Pearson, J., & Stewart, G. R. (1993). The deposition of atmospheric ammonia and its effects on plants. *New Phytologist*, 125(2), 283–305.
- Sommer, S. G., Sibbesen, E., Nielsen, T., Schjørring, J. K., & Olesen, J. E. (2010). A Passive Flux Sampler for Measuring Ammonia Volatilization from Manure Storage Facilities. *Journal of Environment Quality*, 25(2), 241.
- Schlossberg, M. J., McGraw, B. A., Hivner, K. R., & Pruyne, D. T. (2017). Method for Flux-Chamber Measurement of Ammonia Volatilization From Putting Greens Foliarly-Fertilized by Urea. *Clean - Soil, Air, Water*, 45(9).
- Schjoerring, J. K., Sommer, S. G., & Ferm, M. (1992). A Simple Passive Sampler Emission for Measuring Ammonia. *Water, Air, and Soil Pollution*, 62, 13–24.
- Shigaki, F., & Dell, C. J. (2015). Comparison of low-cost methods for measuring ammonia volatilization. *Agronomy Journal*, 107(4), 1392–1400.
- Sommer, S. G., Sibbesen, E., Nielsen, T., Schjørring, J. K., & Olesen, J. E. (2010). A Passive Flux Sampler for Measuring Ammonia Volatilization from Manure Storage Facilities. *Journal of Environment Quality*, 25(2), 241.

- Stainless Steel Design Considerations*. (2002). 1–10. Retrieved from <https://www.azom.com/article.aspx?ArticleID=1145>
- Thöni, L., Seitler, E., Blatter, A., & Neftel, A. (2003). A passive sampling method to determine ammonia in ambient air. *Journal of Environmental Monitoring*, 5(1), 96–99.
- Wu, Y., Gu, B., Erisman, J. W., Reis, S., Fang, Y., Lu, X., & Zhang, X. (2016). PM_{2.5} pollution is substantially affected by ammonia emissions in China. *Environmental Pollution*, 218(x), 86–94.
- Xu, J., Peng, S., Yang, S., & Wang, W. (2012). Ammonia volatilization losses from a rice paddy with different irrigation and nitrogen managements. *Agricultural Water Management*, 104, 184–192.
- Yang, J., Jiao, Y., Yang, W. Z., Gu, P., Bai, S. G., & Liu, L. J. (2018). Review of methods for determination of ammonia volatilization in farmland. *IOP Conference Series: Earth and Environmental Science*, 113(1).
- Yang, Z., Niimi, H., Kanda, K. I., & Suga, Y. (2003). Measurement of ammonia volatilization from a field, in upland Japan, spread with cattle slurry. *Environmental Pollution*, 121(3), 463–467.
- Zhao, M., Wang, S., Tan, J., Hua, Y., Wu, D., & Hao, J. (2016). Variation of urban atmospheric ammonia pollution and its relation with pm_{2.5} chemical property in winter of Beijing, China. *Aerosol and Air Quality Research*, 16(6), 1378–1389.
- Zhenghu, D., & Xiao, H. (2000). Effects of soil properties on ammonia volatilization. *Soil Science and Plant Nutrition*, 46(4), 845–852.

APPENDICES

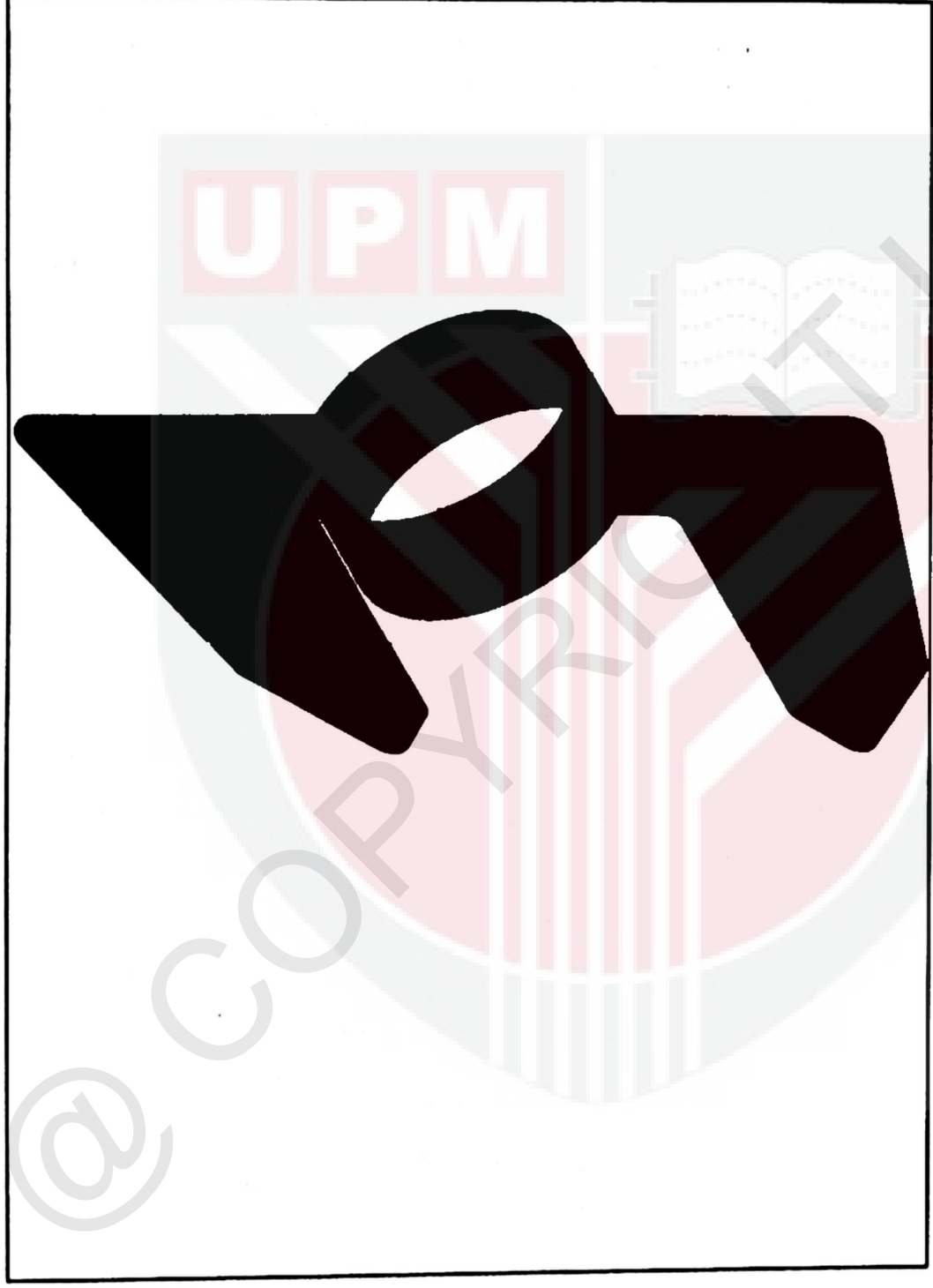

Appendix 1 : 3D drawing for fin

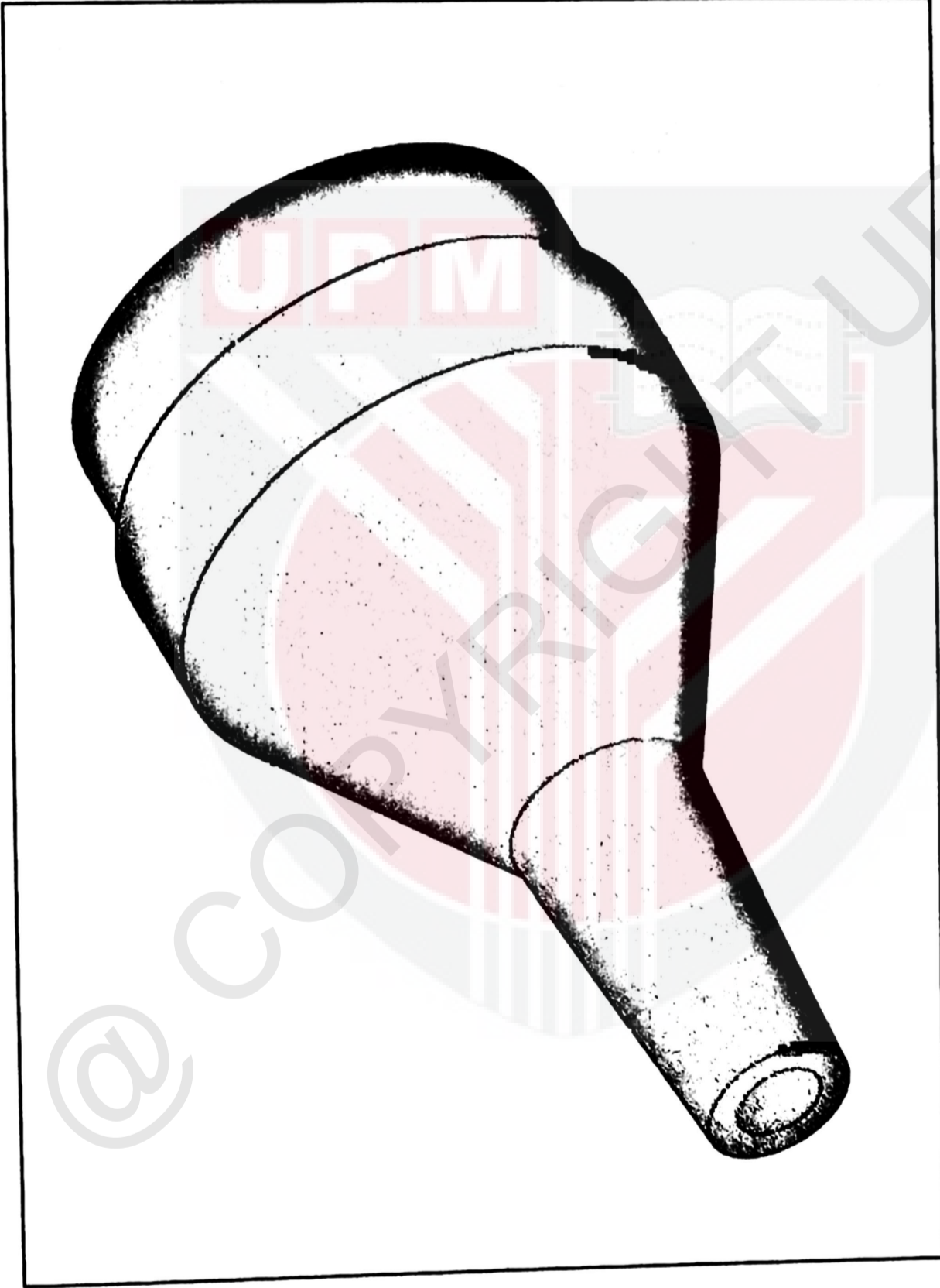

Appendix 2 : 3D drawing for funnel



Appendix 3 : Flashforge Creator Pro 3D

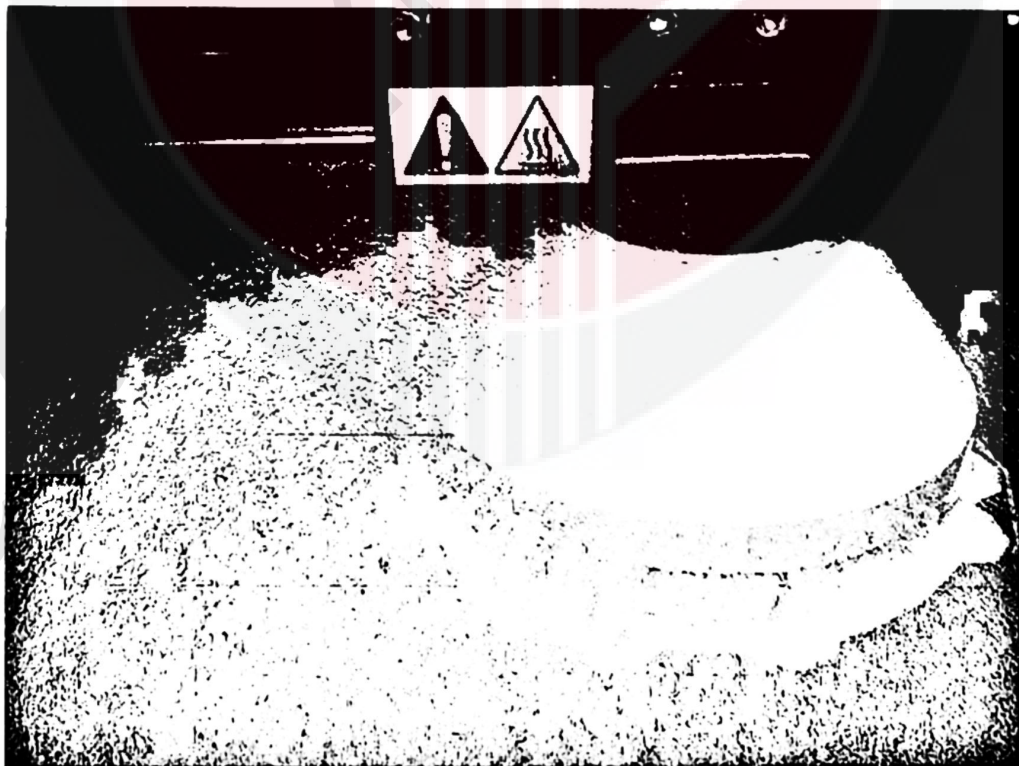

Appendix 4 : Process of printing the funnel



@COPYRIGHT UPM