



**UNIVERSITI PUTRA MALAYSIA**

***DEVELOPMENT OF SOLAR POWERED AUTOMATED WATERING  
SYSTEM***

**CASSANDRA SIMAH ANAK PAUL**

**Ip  
FK 2019 61**

**DEVELOPMENT OF SOLAR POWERED AUTOMATED  
WATERING SYSTEM**



**CASSANDRA SIMAH ANAK PAUL**  
**189754**

**BACHELOR OF AGRICULTURAL AND BIOSYSTEMS ENGINEERING**

**WITH HONOURS**

**FACULTY OF ENGINEERING**

**UNIVERSITI PUTRA MALAYSIA**

**SERDANG, SELANGOR.**

**2018/2019**

## APPROVAL SHEET

This project report here to entitle “Development of Solar Powered Automated Watering System” prepared and submitted by Cassandra Simah Anak Paul in partial fulfilment of the requirement for the Degree of Agricultural and Biosystem is hereby accepted.

Approved by,

\_\_\_\_\_

Date: \_\_\_\_\_

**(Assoc. Prof. Dr. Hasfalina Binti Che Man)**

Project Supervisor

Approved by,

\_\_\_\_\_

Date: \_\_\_\_\_

**(Assoc. Prof. Dr. Siti Khairunniza Binti Bejo)**

Project Examiner

Approved by,

\_\_\_\_\_

Date: \_\_\_\_\_

**(Dr. Mohamad Firdza Bin Mohamad Shukery)**

Project Examiner



## DECLARATION OF THESIS AND COPYRIGHT

The Library,  
Universiti Putra Malaysia,  
43400, Serdang,  
Selangor.

### PERMISSION TO MAKE PHOTOCOPIES OF THESIS

The matter above is referred.

I, **Cassandra Simah Anak Paul** declares that the project report entitled “**Development of Solar Powered Automated Watering System**” belongs to me. The contents of this thesis may be used by anyone for academic purposes of teaching, learning and research only. Universiti Putra Malaysia is permitted to make photocopies of this report for the same academic purpose.

Date :

Signature :

Name : Cassandra Simah Anak Paul

## ACKNOWLEDGEMENT

First of all, I am grateful to God Almighty for His grace in helping me to complete my Final Year Project. Without all His blessings and mercy, it would be impossible for me to successfully complete this project.

Next, my high gratitude and deep appreciation is for my project supervisor, Associate Professor Dr. Hasfalina Che Man for her patient guidance throughout this project. I am extremely grateful and indebted to her for her valuable guidance and encouragement throughout the period of this project.

Besides, I express my sincere gratitude to my beloved family members who have always been to support me while completing my final year project. Last but not least, I would like to thank my fellow friends and those whom directly and indirectly have given me advices and helps in this project completion.

## ABSTRACT

The main purpose of this project is to develop an irrigation system with automatic control system that will control the watering of the plants by using the soil moisture sensor. This control system has been developed by using Arduino IDE Software. Moisture sensor has been chosen as the input device to detect the moisture content of the soil. This control system will activate the motor pump automatically so that the soil will be watered to the optimum moisture content that were set to the optimum values of moisture content such as 60% to 80%, which is best for most plants growth. Besides, as solar source is unlimited in our country, Malaysia, solar energy should be used for good especially to reduce the dependency of electricity particularly in agriculture sector. The result has shown that usage of solar energy will reduce monthly expenses on electric bills through the calculation shown in Chapter 4. The parameters that has been measured to observe the potency of this control system is the moisture content of the soil and the amount of solar voltage used during the implementation of the system. As a conclusion, integrating solar energy with automated watering system is time and cost reducing at the same time.

## ABSTRAK

Tujuan utama projek ini adalah untuk menghasilkan sistem pengairan yang digabungkan dengan sistem kawalan automatik yang akan mengawal penyiraman tumbuhan dengan menggunakan sensor kelembapan tanah. Sistem kawalan ini telah dihasilkan dengan menggunakan Perisian IDE Arduino. Sensor kelembapan telah dipilih sebagai komponen yang memberi input untuk mengesan kandungan kelembapan tanah. Sistem kawalan ini akan mengaktifkan pam motor secara automatik supaya air akan disalurkan ke tanah hingga mencecah kandungan kelembapan optimum yang ditetapkan iaitu 60% hingga 80%. Kandungan kelembapan ini adalah yang terbaik untuk pembesaran tumbuhan. Selain itu, sumber solar sangat mudah didapati di negara kita, Malaysia, oleh itu, tenaga solar harus digunakan secara maksima terutamanya untuk mengurangkan pergantungan kepada tenaga elektrik terutamanya dalam sektor pertanian. Hasilnya menunjukkan bahawa penggunaan tenaga solar akan mengurangkan perbelanjaan bulanan pada bil elektrik melalui pengiraan yang ditunjukkan dalam Bab 4. Parameter yang telah diukur untuk melihat potensi sistem kawalan ini adalah kandungan kelembapan tanah dan jumlah solar voltan yang digunakan semasa pelaksanaan sistem. Sebagai kesimpulan, menggabungkan tenaga solar dengan sistem penyiraman automatik menyumbangkan kepada pengurangan masa yang digunakan untuk menyiram tumbuhan dan juga pengurangan kos operasi.

## TABLE OF CONTENT

<b>APPROVAL SHEET</b> .....	i
<b>DECLARATION OF THESIS AND COPYRIGHT</b> .....	ii
<b>ACKNOWLEDGEMENT</b> .....	iii
<b>ABSTRACT</b> .....	iv
<b>ABSTRAK</b> .....	v
<b>TABLE OF CONTENT</b> .....	vi
<b>LIST OF TABLES</b> .....	viii
<b>LIST OF FIGURES</b> .....	viii
<b>CHAPTER 1</b> .....	1
<b>INTRODUCTION</b> .....	1
<b>1.1 Overview</b> .....	1
<b>CHAPTER 2</b> .....	4
<b>LITERATURE REVIEW</b> .....	4
<b>2.1 Solar Energy</b> .....	4
<b>2.2 Solar Panel</b> .....	5
<b>2.2.1 Monocrystalline Solar Panel</b> .....	6
<b>2.2.2 Polycrystalline Solar Panel</b> .....	6
<b>2.2.3 Thin- Film Solar Panel</b> .....	7
<b>2.3 Battery</b> .....	8
<b>2.3.1 Nickel Cadmium (Ni- Cd)</b> .....	8
<b>2.3.2 Lithium Ion (Li- On)</b> .....	9
<b>2.3.3 Lead Acid</b> .....	9
<b>2.4 Soil Moisture Sensor</b> .....	10
<b>2.4.1 Level of Moisture Needed in Soil for Plants</b> .....	11
<b>2.5 Relay</b> .....	11
<b>2.5.1 Microcontroller &amp; Arduino</b> .....	12
<b>2.6 Motor Pump</b> .....	14
<b>2.7 Smart Watering System for Agricultural Sector</b> .....	15
<b>2.8 Solar Panel and Converter/Inverter</b> .....	15
<b>2.8.1 Solar powered watering system</b> .....	17
<b>CHAPTER 3:</b> .....	18
<b>MATERIALS &amp; METHODOLOGY</b> .....	18
<b>3.1 Overview</b> .....	18
<b>3.2 Apparatus and Materials</b> .....	19
<b>3.3 Flow Chart of Methodology</b> .....	23

<b>3.4</b>	<b>Project Phase</b> .....	25
<b>3.5</b>	<b>Project Development</b> .....	25
<b>3.5.1</b>	<b>Software development</b> .....	25
<b>3.5.2</b>	<b>Hardware development</b> .....	28
<b>3.5.3</b>	<b>Arduino Uno board</b> .....	28
<b>3.5.4</b>	<b>Soil moisture sensor</b> .....	29
<b>3.5.5</b>	<b>Relay</b> .....	30
<b>3.5.6</b>	<b>Motor pump</b> .....	30
<b>3.5.7</b>	<b>Solar panel</b> .....	30
<b>CHAPTER 4</b>	.....	32
<b>RESULTS AND DISCUSSION</b>	.....	32
<b>4.1</b>	<b>Introduction</b> .....	32
<b>4.2</b>	<b>Watering System Relay</b> .....	32
<b>4.4</b>	<b>Comparison of Automated Solar Powered Watering System and Electric Power Supply Dependent Watering System</b> .....	34
<b>4.4.1</b>	<b>Electric Power Supply Dependent Watering System</b> .....	35
<b>4.4.2</b>	<b>Automated Solar Powered Watering System</b> .....	36
<b>CHAPTER 5</b>	.....	37
<b>CONCLUSION AND RECOMMENDATION</b>	.....	37
<b>5.1</b>	<b>Conclusion</b> .....	37
<b>5.2</b>	<b>Recommendations</b> .....	37
<b>REFERENCES</b>	.....	38
<b>APPENDICES</b>	.....	42
<b>Appendix A:</b>	<b>Relay programming</b> .....	42
<b>Appendix B:</b>	<b>Motor Pump Specifications</b> .....	44

## LIST OF TABLES

Table 1: Sensor value description .....	33
Table 2: Moisture Capacity for Peat Soil .....	33
Table 3: Data tabulation .....	33

## LIST OF FIGURES

Figure 1: Different types of solar panel .....	5
Figure 2: Monocrystalline solar panel.....	6
Figure 3: Polycrystalline solar panel.....	7
Figure 4: Thin- film solar panel .....	7
Figure 5: Ni- Cd batteries.....	8
Figure 6: Lithium ion battery .....	9
Figure 7: Lead acid battery .....	9
Figure 8: Soil moisture sensor.....	10
Figure 9: Soil water content .....	11
Figure 10: Arduino compatible 5V relay .....	12
Figure 11: Microcontroller.....	13
Figure 12: Arduino UNO board .....	13
Figure 13: Pumps working principle.....	14
Figure 14: Flow of energy conversion from solar cell to PV system.....	16
Figure 15: Schematic diagram of residential grid connected to solar system .....	16
Figure 16: Solar- powered stock irrigation .....	17
Figure 17: Experimental setup of the design.....	18
Figure 18: Motor pump .....	19
Figure 19: Hose from pump to water dripper.....	20
Figure 20: Soaker hose for water dripper.....	20
Figure 21: Water dripper.....	20
Figure 22: Polycrystalline solar panel used .....	21
Figure 23: Solar charge controller and lead acid battery .....	21
Figure 24: Arduino Uno board and relay .....	22
Figure 25: Soil moisture sensor probe .....	22
Figure 26: Optimum soil moisture content level.....	23
Figure 27: Flow chart of methodology.....	24
Figure 28: Block diagram of watering system developed.....	25
Figure 29: Command used (Part 1) .....	26
Figure 30: Command used (Part 2) .....	27
Figure 31: Arduino Uno board with labels .....	29
Figure 32: Two legged lead soil moisture sensor.....	29
Figure 33: Relay module .....	30
Figure 34: Front and backside of motor pump.....	30
Figure 35: Positive and negative terminal.....	31
Figure 36: Solar charge controller.....	31
Figure 37: Tariff rates prices according to TNB website.....	35

# CHAPTER 1

## INTRODUCTION

### 1.1 Overview

Nowadays, the increased of plantation area in Malaysia has led to high demand of water usage especially in some area where water are limited. Irrigation system is one of a method to distribute water to intended area. This system is mostly used for agriculture purpose and the effectiveness is based on the system used. Human live on agriculture and watering system since long ago. Automation plays an important role in economics of the world. Therefore, engineers strive to innovate with combined automatic devices in order to produce complex systems that assist human with their activities to make the system automatically works by itself (Abdelkerim et.al., 2013). In agriculture and intensive plantation, labor and security consume more than 30% of total production cost for irrigation (Hema N, Reema and Monisha, 2012).

Some of the crop or agriculture plants do not need irrigation every day. Over-watering can create problems such as shallow root systems, causing the plant to become stressed in adverse environmental conditions. Plants stressed by excessive watering are more susceptible to disease and pest infestations. Studies have shown that a properly configured soil moisture sensor can reduce outdoor water use by up to 62 percent or more over traditional irrigation methods. By watering the plants when needed, the planters can increase crop health, promote deeper root growth, and make the plants more disease resistant. The soil moisture sensor eliminates the need for constant monitoring and guesswork based on general observations of water stress. Moreover, the controller or timer can be programmed to tailor watering schedules and run times automatically based on plant water needs by using moisture sensor. The controller should be adjusted

seasonally to the water requirements since many plants do not need irrigation regularly such as during frequent or heavy rainfall events. The controllers available can be programmed to use weather information and specific site conditions to determine how much water to apply and when to irrigate.

Since Malaysia has mostly sunny days every year, solar system should be utilized well for operating automatic irrigation system. Solar power is an eco- friendly source of water supply that is low maintenance. It is a long-life source compared to a diesel generator or direct current and there will be no running cost (Hassan W. and Farrukh K., 2018). Besides, the cost of electricity bills for irrigation system in agriculture sector is high. Within year 2000 to 2010, Malaysia's electricity consumption has increased in average of 8% per year from 69, 280 GWh to 137, 909 GWh respectively. Current contribution from renewable sources for electricity remains very low where solar energy contributes only 0.007% of the total generated electricity in Peninsular Malaysia. (Christopher T., 2012). Current electricity tariff as referred to TNB Tariff Book for general specific agriculture tariff is RM30.30 per kW and for peak/off- peak specific agriculture tariff is RM 40.80 per kW with minimum charge of RM 600.00. (TNB, 2014). Therefore, solar powered watering system is important to be established, as it will be helpful for the users and environment.

In this project, the parameters that were controlled for solar powered automated watering system are the soil moisture and the amount of water needed to be distributed to the plants.

These two parameters are most important to determine the efficiency of the soil moisture sensor and also the efficiency of the water distributed which will be affecting the growth of the plants.

## **1.2 Problem Statement**

Most of the traditional pump systems mainly work with a diesel engine or with the local power grid. However, these two modes of operations present disadvantages compared to solar pumps. In many rural areas, especially in developing and emerging countries, the access to the electricity grid is not always guaranteed. In this case, farmers cannot rely on the traditional irrigation system. Thus, using an independent and alternative energy system can be a solution for the farmer to secure a safe power source and for the public grid plants growth. Some small gardening or a greenhouse faces problems in their watering system such as uneconomical agricultural water use and also the performance of irrigation operational performance. Agriculture utilizes about 68% of total water consumption in Malaysia but irrigation effectiveness is 50% at best in the larger irrigation project and less than 40% in the smaller ones (Toriman M.E. and Mokhtar M., 2012). Therefore, a self- operating system is recommended in order to supply adequate irrigation to the plants at the right time required.

## **1.3 Objectives**

The general purpose of this research is to develop a motor pump used operating automatically by moisture level sensor using solar power. The application of the developed system could be used in watering system in greenhouse, nurseries or any vegetables plantation. The basic objectives of this study are to:

1. To design a simple system for soil moisture monitoring
2. To integrate solar powered motor pump with automated watering system to facilitate the watering task.

## CHAPTER 2

### LITERATURE REVIEW

#### 2.1 Solar Energy

Sun provided the Earth with various energies such as in form of solar energy, radiant light and heat (V. Balasubramaniam, 2017). These energies have been utilized and developed in human civilization since ancient times. Across the centuries, there are many other alternative energies have been discovered and hence competitions between the sources of energy start from solar radiation to the other resources such as hydroelectricity, wind energy, wave power and also thermal. In rural areas, renewable energy provides benefits to the environment. Generally, renewable energy increase local economy, provide jobs and contributes to the growth of power grid with renewable energy based. It is perfect as rural area usually have more space and farmland to have solar panels while still have the ability to farm crops or rear livestock (Ray, N. M., 2017) Using solar energy should be active in all agricultural areas which will help in achieving the increasing need for agricultural products.

The base of entire agricultural crops depend on the capability of plants to transform solar energy into stored chemical energy. Solar energy is the most suitable option compared to other renewable energy sources as solar energy is in line with the air condition demand. (Torshizi, M.V. and Mighani, A. H., 2017)

## 2.2 Solar Panel

A solar panel is a collection of solar cells. Although each solar cell provides a relatively small amount of power, many solar cells spread over a large area can provide enough power to be useful. To get the most power, solar panels have to be pointed directly at the sun. solar panels need surface area, more exposure means more electricity can be converted from light energy.

Solar energy absorbed by solar panel or in other word Photovoltaic Cell (PV). 'Photo' means light and 'voltaic' means electricity. Photovoltaic system uses silicon cells to convert solar radiation into electricity. The PV system captures the sun's energy using solar photovoltaic cells. The cells convert the sunlight into electricity, which can be used to run household appliances and lighting. Each cell is made from one or two layers of semi- conducting material, usually silicon.

PV cells are the special made semiconductor such as silicon which are widely used. Few types of PV cells are shown in Figure 1 below. Basically when the light strikes the cell, a certain portion of it absorbed by semiconductor. Energy knocks the electron, allowing them to move freely. PV also has electric field that only allow electron move in certain direction. This flow of electron is called current (Towler, B. F., 2014).



Figure 1: Different types of solar panel

### 2.2.1 Monocrystalline Solar Panel

Monocrystalline solar cells are made out of cylindrical shape silicon blocks. To optimize performance and lower costs of a single monocrystalline solar cell, four sides are cut out of the cylindrical blocks to make wafers. As shown in Figure 2 is the example of monocrystalline solar panel. Monocrystalline solar panel has the highest efficiency rates, space efficient and live the longest. This solar panel tends to perform better at low- light conditions (Energy Informative, n.d.).

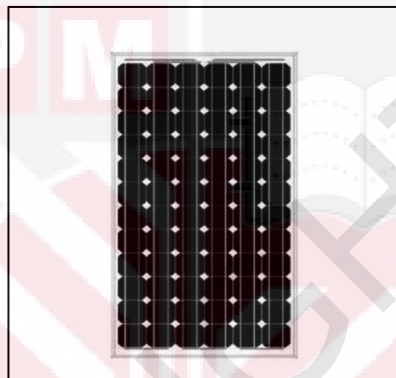

Figure 2: Monocrystalline solar panel

### 2.2.2 Polycrystalline Solar Panel

Polycrystalline solar panels are consist of silicon which are melted and poured into a square mould, which is cooled and cut into perfectly square wafers. As shown in Figure 3 is the example of polycrystalline solar panel The process used to produce polycrystalline is simpler and less costly. This solar panel is likely to have lower heat tolerance than monocrystalline solar panels. However, the efficiency of this type of solar panel is between 13 to 16% because of low silicon purity (Energy Informative, n.d.).

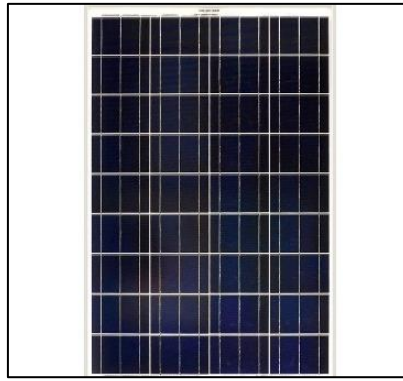

Figure 3: Polycrystalline solar panel

### 2.2.3 Thin- Film Solar Panel

Thin- film solar panel is manufactured by depositing one or more thin layers of photovoltaic material onto a substrate. Thin- film solar panel's efficiency between 7 to 13%. The production of thin- film solar panel is simple and flexible. As shown in Figure 4 is the example of thin- film solar panel. This type of solar panel is low in space- efficiency and more likely to degrade faster compared to other type of solar panels (Energy Informative, n.d.).



Figure 4: Thin- film solar panel

## 2.3 Battery

A battery is commonly called as electric cell where it produces electricity from a chemical reaction. A battery consists of two or more cells connected in series or parallel. A cell consists of a negative electrode which executes ions either positive or negative electrodes. The electrolyte may be aqueous or non- aqueous, in liquid, paste or solid form. When the cell is connected to an external load or device to be powered, the negative electrode supplies a current of electrons that flow through the load and are accepted by the positive electrode. However, when the external load is removed, the reaction is ceased. A primary battery can convert its chemicals into electricity only once and must be disposed later. A secondary battery has electrodes that can be regenerated by passing electricity back through it (Bewick, S., et. al., 2019).

### 2.3.1 Nickel Cadmium (Ni- Cd)

Ni- Cd batteries have been the most used batteries for years. As shown in Figure 5 is the example of nickel cadmium batteries. This battery is suitable for applications where a self- contained power source increases the reliability of the end product. This battery is high energy density, high- rate discharges and fast recharge (Elsevier Inc., 2007).



Figure 5: Ni- Cd batteries

### 2.3.2 Lithium Ion (Li- On)

Lithium- ion is the lightest of all metals and has significant electrochemical potential and provides the biggest energy density for weight. As shown in Figure 6 is the example of lithium ion battery. This battery type is low maintenance battery where it stores no memory and no scheduled cycling is required to prolong the battery's life. The energy density of lithium- ion is typically twice of the standard nickel- cadmium (Buchmann, I., 2013).



Figure 6: Lithium ion battery

### 2.3.3 Lead Acid

Lead acid battery is an electrical storage device that uses a reversible chemical reaction to store energy. As shown in Figure 7 is the example of lead acid battery. It uses a combination of lead plates or grids and an electrolyte consisting of a diluted sulphuric acid to convert electrical energy into potential chemical energy and back again. The electrolyte of lead- acid batteries is hazardous to our health and may produce burns and other permanent damage if you come into contact with it.



Figure 7: Lead acid battery

## 2.4 Soil Moisture Sensor

Soil moisture measurement is important in agriculture field as it allows farmers to manage their irrigation system more efficient. As shown in Figure 8 is the example of soil moisture sensor. Arduino based soil moisture sensor is controlled by instructions that were uploaded into it through a software. Connecting a moisture sensor to an ordinary timer irrigation system will create some smart features such as stopping irrigation when the soil is already wet enough. The system is intended primarily for application in agricultural activities. (Radman V. and Radunjc, M., 2017)

Soil moisture sensor (SMS) is a sensor connected to an irrigation system controller that measures soil moisture content in the active root zone before each scheduled irrigation event and bypasses the cycle if soil moisture is above a user- defined set point. Soil moisture sensors like rain sensors are considered rain shut off devices, but while rain sensors measure evapotranspiration rates, soil moisture sensors measure real time soil moisture (Clark, M. et. al., 2008).

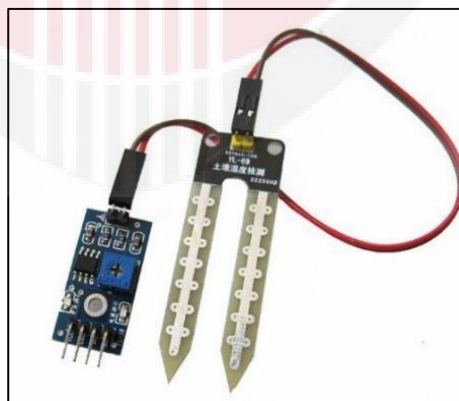

Figure 8: Soil moisture sensor

### 2.4.1 Level of Moisture Needed in Soil for Plants

Depending on the plant types, moisture level is the most important parameter in determining the amount of water to be irrigated to the plant. As shown in Figure 9 is the illustration for soil water content. These days, soil moisture is not taken into serious consideration as the tools for moisture detection is difficult to find especially for the farmers from rural areas. Soil water is the major component of the soil in relation to plant growth. If the moisture content of a soil is optimum for plant growth, plants can readily absorb soil water. Soil water dissolves salts and makes up the soil solution, which is important as medium for supply nutrients to growing plants (AgriInfo, 2015).

In order to assess soil water content, one needs to monitor soil moisture at several depths from just below the soil layer or cultivation depth to about 70% of effective root depth (Intermountain Tree Fruit Production Guide, n.d.).

During certain growth stages especially flowering and the formation of fruit, root growth is retarded or ceases completely. Annual crops will face increased risk of water stress during the development of reproductive organs when root growth ceases. Reduced root growth especially in annuals is prone to mark soil moisture sensitivity conditions at certain stages of growth (MAIT Industries, 2019).

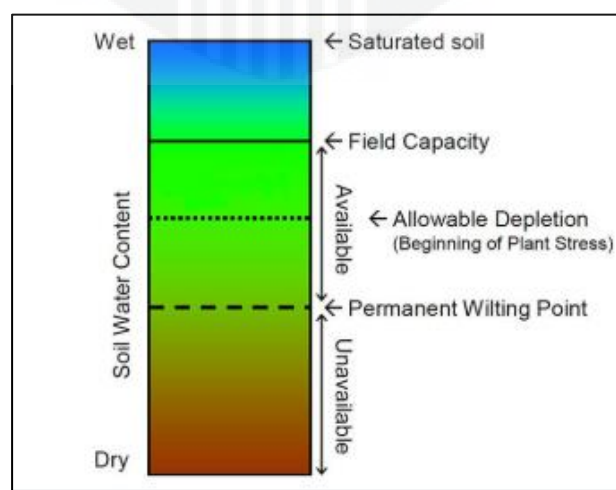

Figure 9: Soil water content

## 2.5 Relay

Relays are switches that open and close circuits electromechanically or electronically. As shown in Figure 10 is the example of Arduino compatible 5V relay. It controls one electrical circuit by opening and closing contacts in another circuit. As relay diagrams show, when a relay contact is normally open (NO), there is an open contact when the relay is not energized. When a relay contact is Normally Closed (NC), there is a closed contact when the relay is not energized. Protective relays can prevent equipment damage by detecting electrical abnormalities, including overcurrent, undercurrent, overloads and reverse currents. In addition, relays are also widely used to switch starting coils, heating elements, pilot lights and audible alarms (Galco Electronics, n.d.).

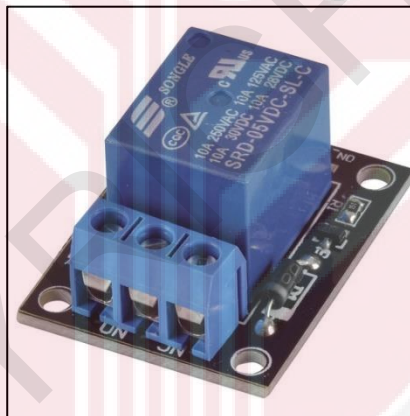

Figure 10: Arduino compatible 5V relay

### 2.5.1 Microcontroller & Arduino

Microcontroller is a highly integrated chip which performs controlling functions. A microcontroller or embedded controller is similar to a microprocessor as used in a personal computer but with a great additional functionality combined onto the same monolithic semiconductor substrate. Microcontrollers or one chip microcomputers are used to control a wide range of electrical and mechanical appliances. As shown in Figure 11 is the example of microcontroller. Since first introduced, microcontrollers have

evolved to the point where they can use for increasing complex applications. Some microcontrollers used today are also programmable in order to expand the number of applications in which they can be used. In modern terminology, it is similar to but less sophisticated than a system on a chip (SoC). SoC may include a microcontroller as one of its components (Wikipedia, 2018).

Arduino is an open source hardware and software company project and user community that designs and manufacturers single- board microcontrollers and microcontroller kits for building digital devices and interactive objects that can sense and control objects in the physical and digital world. As shown in Figure 12 is the example of Arduino Uno board. The boards use single or double- row pins to help with programming connections and incorporated into the circuit. Boards are loaded with program code through a connection to a computer (Wikipedia, 2018).

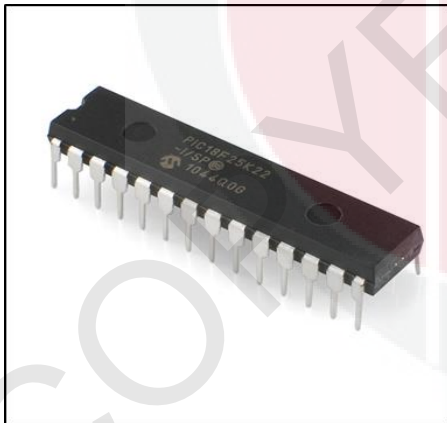

Figure 11: Microcontroller

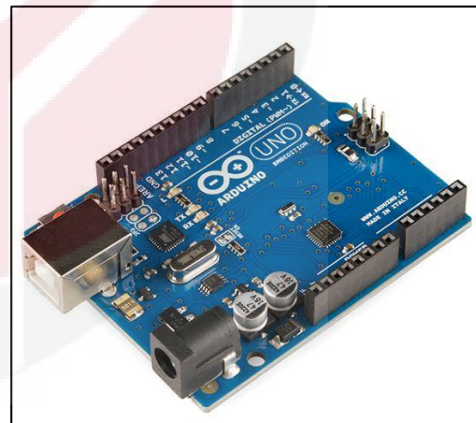

Figure 12: Arduino UNO board

## 2.6 Motor Pump

Motor pump is used for water withdrawing from water sources designed especially for irrigation system in agriculture area. It works by moving liquid using energy to increase the amount of pressure in the system. As we know that water are the most essential needs for plants to grow healthier. However, in some places water source are located underground, further or lower than the plants were planted. Therefore, motor pump is needed in order to deliver and distribute water supply as intended. As shown in Figure 13 is the working principle of motor pumps.

There are two types of pumping methods: dynamic pumps and positive displacement pumps. Dynamic pumps consist of centrifugal and axial pumps and are operated by developing a high liquid velocity that converted into pressure in a flow passage diffusion. Dynamic pumps are lower efficiency than positive displace pumps. Nevertheless, both pumps operate at relatively higher speed and provide higher flow rate. Dynamic pumps usually require low maintenance than positive displacements pump. Dynamic pumps generally provide better efficiency and flexibility and are suitable for large pumping tasks such as broad- acre irrigation (AgInnovators, n.d.).

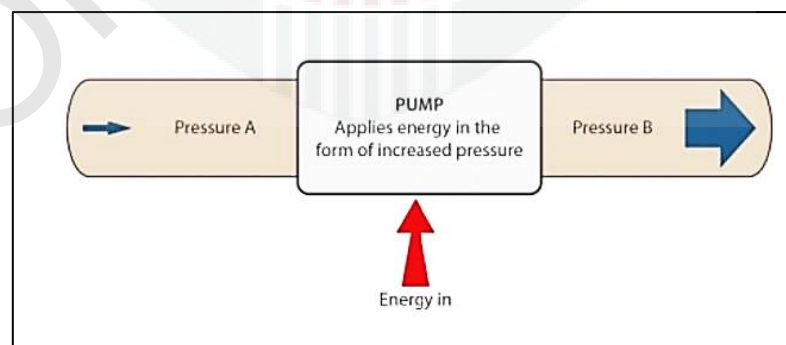

Figure 13: Pumps working principle

## **2.7 Smart Watering System for Agricultural Sector**

Agricultural Sector in Malaysia mostly depending on rainfall for their watering system. Although rainfall is reasonable some plants such as oil palm cannot really rely on the rainfall. Malaysia obtains an annual average rainfall of more than 2,500 mm mainly due to the Southwest and Northeast monsoons. Malaysia is rich in water resources compared to other regions in the world. The mean annual water supply with total land area of 330,000 km<sup>2</sup> amount to 990 billion m<sup>3</sup>. Out of the total 566 billion m<sup>3</sup> of surface runoff, 147 billion m<sup>3</sup> are found in Peninsular Malaysia, 113 billion m<sup>3</sup> in Sabah and 206 billion m<sup>3</sup> in Sarawak.” (Wong, C.L., et. al., 2016).

However, during certain period of time in Malaysia will be a dry season where draught is most likely to happen thus causing the plants to wilt. Therefore, installing a smart watering system is a quick- witted way to solve water insufficient problem. Other than preventing diseases and weeds, gardening timing will also be flexible and also conserves water and time. Besides, it also aids in retaining nutrients for the plants thus encouraging a healthy root growth (Finneran R. and Wilson M., 2015).

## **2.8 Solar Panel and Converter/Inverter**

Solar panel consists of solar cells that absorb sunlight as an energy supply to produce electricity. Solar panel usually use sun to induce electricity through photovoltaic effect. The solar panel (cells) must be avoided from contacting with mechanical harm and dampness. As shown in Figure 14 is the flow of energy conversion from solar cell to PV system. Most cells conditions are depending on the cells film. Cells must be connected electrically in series.

Photovoltaic solar panels absorb sunlight as a source of energy to generate electricity. A photovoltaic (PV) module is packaged, connected assembly of typically 6x10 photovoltaic solar cells. (Wikipedia, 2018)

A solar inverter of PV inverter is a type of electrical converter which converts the variable direct current (DC) output of a photovoltaic (PV) solar panel into a utility frequency alternating current (AC) that can be fed into commercial electrical grid or used by a local off- grid electrical network. As shown in Figure 15 is the schematic diagram of residential grid connected to solar system. Solar power inverters have special functions adapted for use with photovoltaic arrays including maximum power tracking and anti- islanding protection. (Wikipedia, 2018)

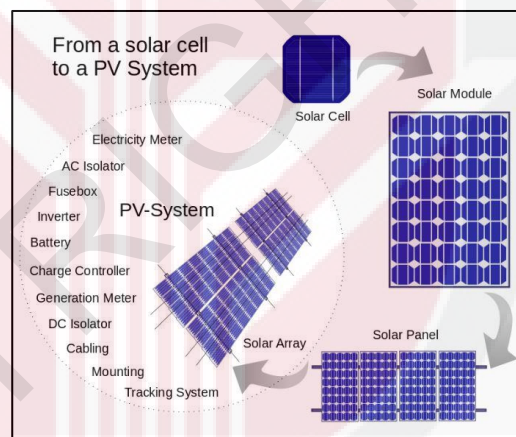

Figure 14: Flow of energy conversion from solar cell to PV system

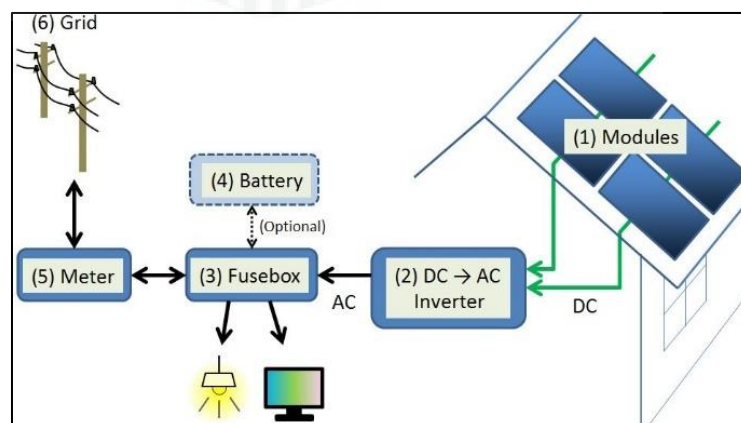

Figure 15: Schematic diagram of residential grid connected to solar system

### 2.8.1 Solar powered watering system

Solar powered watering system is one of a user- friendly method. Other than farm irrigation, this watering system can be used for stock irrigation and also internal uses too. PV modules produce electricity as form of energy storage to operate systems even at night time. From crop irrigation to stock watering to domestic uses, photovoltaic- powered pumping systems meet a broad range of water needs. Most of these systems have the added advantage of storing water for use when the sun is not shining, eliminating the need for batteries, enhancing simplicity and reducing overall system costs (Eker B., 2005).Currently, Malaysia has become one of the massive solar photovoltaic producers in the world. It has one of the highest resource- efficient solar farms in the world. As shown in Figure 16 is the example of set up for solar- powered stock irrigation.

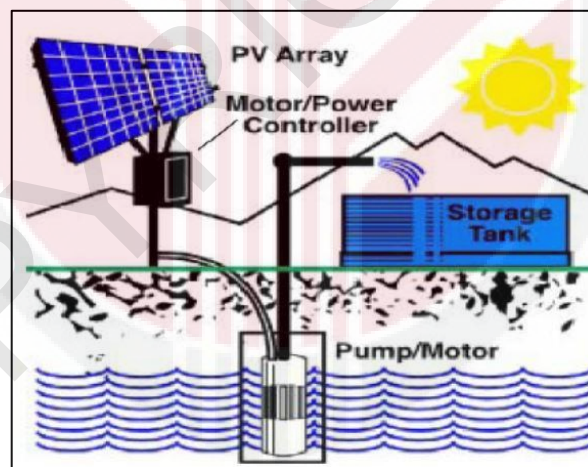

Figure 16: Solar- powered stock irrigation

## CHAPTER 3:

### MATERIALS & METHODOLOGY

#### 3.1 Overview

The scope of works in this project is to develop a prototype of solar powered automated watering system assisted by soil moisture sensor. The codes of command is developed to control the irrigation time based on the information obtained from moisture level sensor in the soils. As shown in Figure 17 is the experimental setup. The system was left to operate for 24 hours in order to determine the voltage used to irrigate the soil.

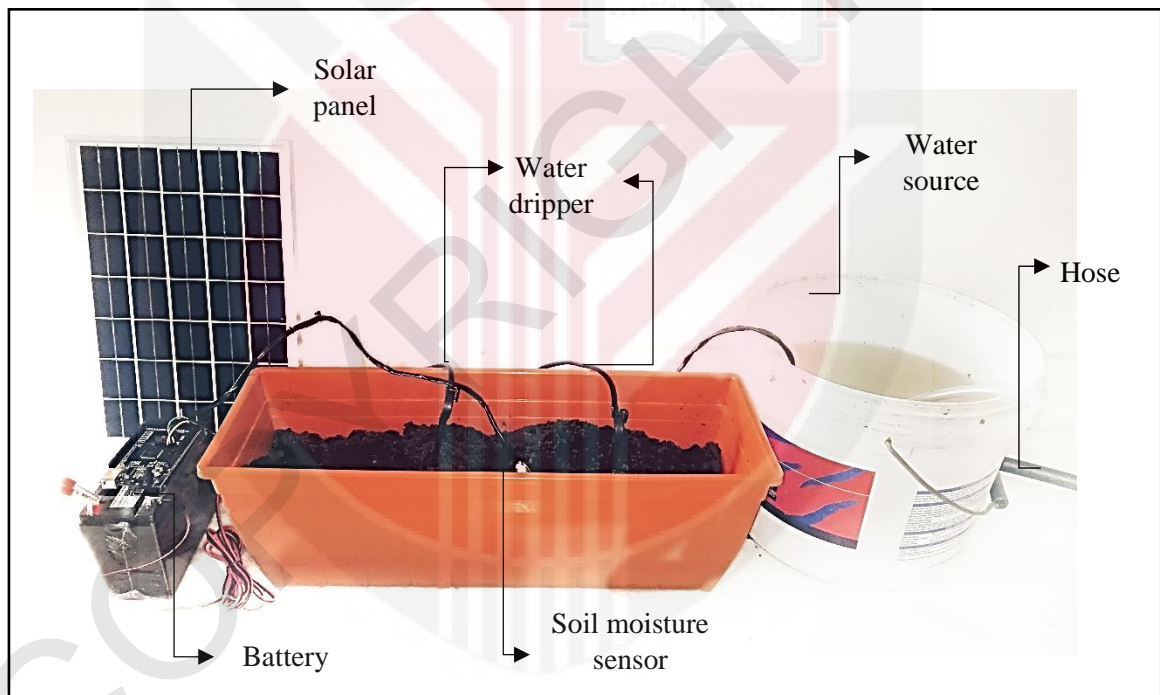

Figure 17: Experimental setup of the design

### 3.2 Apparatus and Materials

Motor pump was obtained from previous class project and has been reused for this project. The motor pump was utilised with direct current (DC) of 12V. As shown in Figure 18 is the motor pump used. This motor pump was used to pump water source out in order to distribute adequate water to plants and the required amount of the pump is only one. Motor pump was connected with small hoses where the input hose was put inside the water tank as it will pump out the water inside the tank, while the discharge hose was directed to water drippers and distribute to plants.

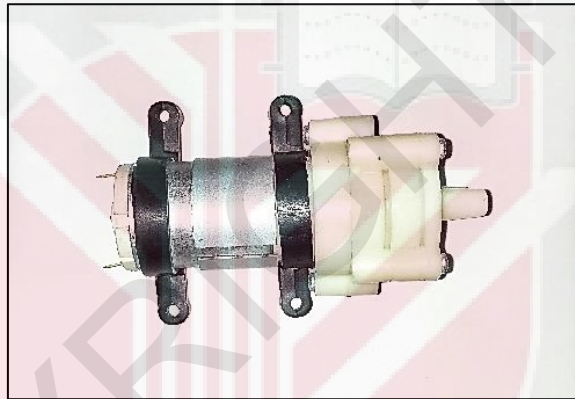

Figure 18: Motor pump

Pipes and hoses were purchased from nearby hardware store in Taman Sri Serdang. As shown in Figure 19 and 20 are the hoses used in the design. The diameter and length of the pipes and hoses was chosen depending on the requirements. Pipes and hoses were used to deliver sufficient and consistent water to intended plants. The required quantity of the pipes and hoses also depending on the area of where the project was held. As shown in Figure 21 is the water dripper used in the design.

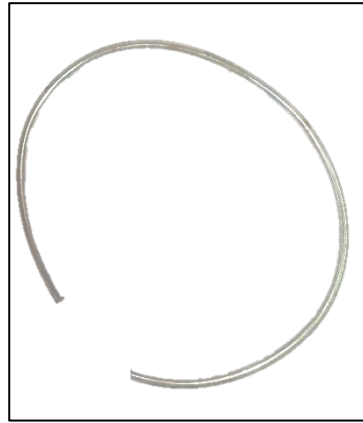

Figure 19: Hose from pump to water dripper

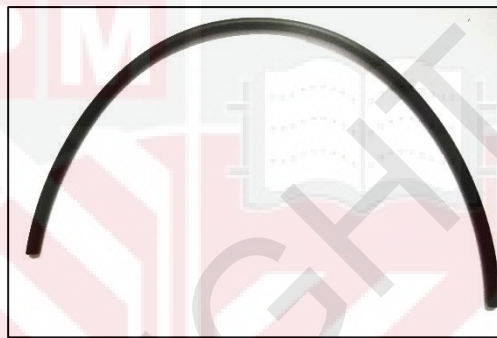

Figure 20: Soaker hose for water dripper



Figure 21: Water dripper

Solar panel, battery and controller were purchased from online shopping site. As shown in Figure 22 is the solar panel used in the design. This solar panel was used to absorb and derive energy from solar energy. While solar inverter can be used to convert direct current (DC) to alternative current (AC) electrical power which can be used to run the pump. As shown in Figure 23 is the solar charge controller and lead acid battery used in the design. The cell type will be polycrystalline solar panel with 50W maximum power. Solar panel was placed at a safe and open space that is out of shade, as it need sunlight to work.



Figure 22: Polycrystalline solar panel used

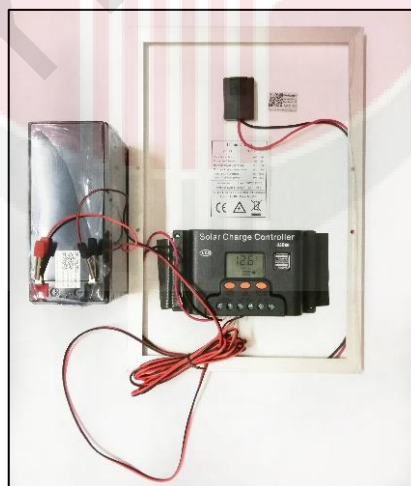

Figure 23: Solar charge controller and lead acid battery

Arduino Uno Board and soil moisture sensor were obtained from previous class project. This Arduino based soil moisture sensor is easy but powerful single computer board. It is basically an open- source electronics prototyping platform based on flexible and easy to use both hardware and software. The quantity needed is one. As shown in Figure 24 is the Arduino Uno board and relay used in the design. Mostly, Arduino board is preferred for this project as it is suitable to develop simple and small project due to its efficiency. Soil moisture sensor was connected to an irrigation system controller that measures soil moisture content in active root zone of soil. The probe was placed in the soil to measure the moisture. As shown in Figure 25 is the soil moisture sensor used in the design. Quantity of the soil moisture sensor probe used in this project was only one.

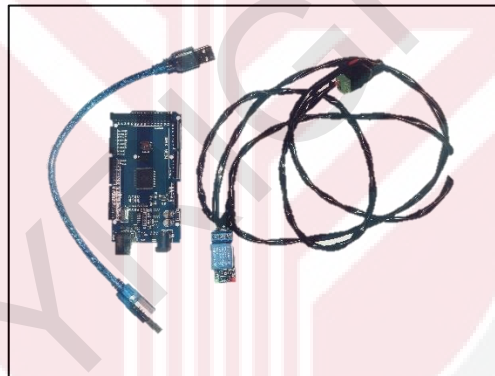

Figure 24: Arduino Uno board and relay



Figure 25: Soil moisture sensor probe

### 3.3 Flow Chart of Methodology

The development of this project is divided into two parts which are hardware and software. Software includes coding and instructions needed depending on the parameters that should be analysed first such as the determination of optimum soil moisture and development of codes for command,. While, hardware includes Arduino board, sensor circuits and some physical tools such as connection of solar panel and controller to the pump, to locate and assemble the solar panel. As shown in Figure 26 is the optimum soil moisture content level generally for every type of the soil (Pitts, L., 2016). This soil moisture content level is very useful to be used as the threshold in the developed code of command.

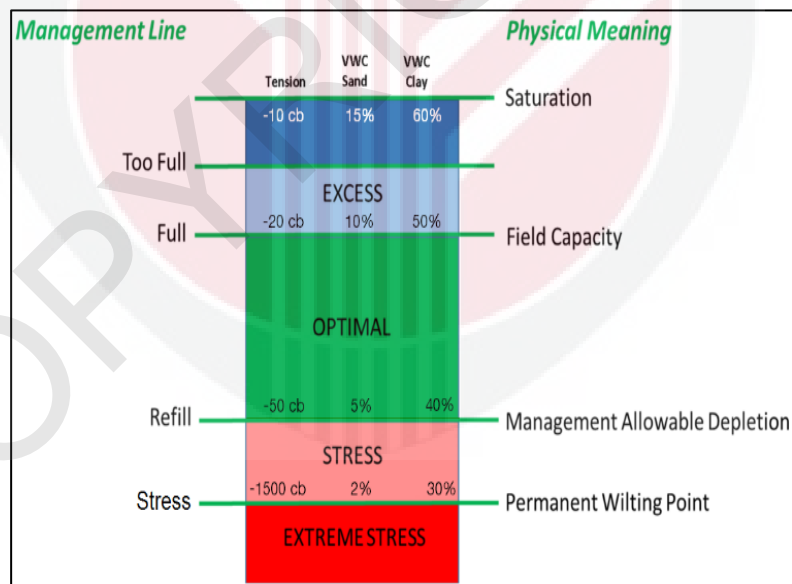

Figure 26: Optimum soil moisture content level

As shown in Figure 27 is the flow chart of methodology that was implemented during the accomplishment of this project.

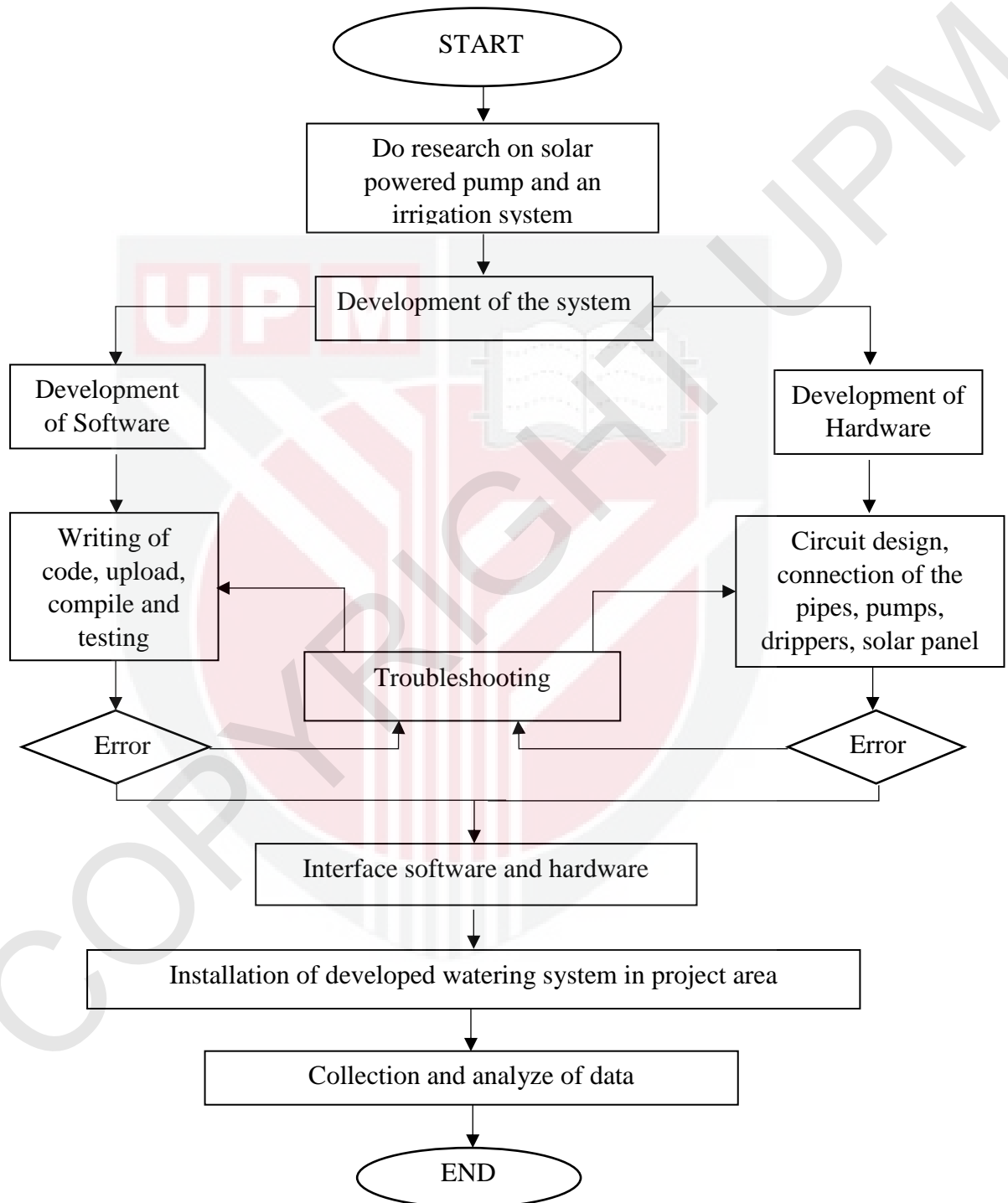

Figure 27: Flow chart of methodology

### 3.4 Project Phase

The project was conducted outdoor where there are unlimited solar energy and away from shaded area. The area is an open area and easy for the solar panel to get direct sunlight in order to convert the energy and transferred to battery. Peat soil has been chosen as the experimental soil throughout this project and were placed in a vase. Soil in the vase was left outdoor with solar powered watering system. All the apparatus such as motor pump, relay, Arduino uno board and solar panel were connected. These apparatus were meant to successfully irrigate the soil whenever it reaches the lowest moisture content and stopped irrigating when it reaches optimum moisture content. The time, soil moisture and the value of solar energy left were recorded.

### 3.5 Project Development

As this project is consisting of two main part which are the development of hardware part and also software part, the details of both parts are discussed.

#### 3.5.1 Software development

Software development was a phase where the codes were compiled in the microcontroller by using Arduino IDE Software. This coding involved pins that were used on the Arduino Uno Board, the moisture value and the command for relay to switch in and off. The coding is shown in Appendix A.

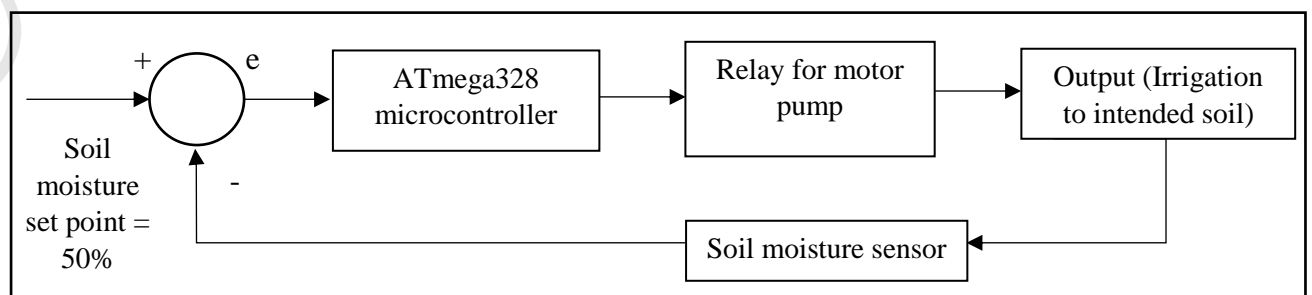

Figure 28: Block diagram of watering system developed

The block diagram shown in Figure 28 shows the overall processing principle of the watering system. It indicates the flow of information around the closed-loop watering system and the function of each part of the system. The microcontroller has been used as the central unit to control the relay to automatically activate the motor pump. The automatic watering system has been implemented with soil moisture sensor where the function of the sensor is to send feedback elements which was detecting the moisture level set and send the signals to the microcontroller. Then, the microcontroller translated the input signals from the sensors and turn the motor pump on to maintain the soil moisture level at its optimum.

In this project, the value of soil moisture level was set at 50% where when the moisture level reached 50% or lower, the relay will received signals and will turn on the motor pump. Thus, the soil or plants will be irrigated. However, the optimum moisture level is different for different types of soil and plants.

With reference to DFRobot website, the command used in this system are shown in figure 29 and figure 30.

```
int moisture = A0;
int moisturevalue = 0;
#define Relay 13
void setup()
{
  Serial.begin(9600);
  pinMode(Relay, OUTPUT);
  digitalWrite(Relay, LOW);
  digitalWrite(Relay, HIGH);
  Serial.println("Reading From the Sensor ...");
}
void loop()
{
  moisturevalue = analogRead(A0);
  delay(1000);
  if (moisturevalue < 300)
```

Figure 29: Command used (Part 1)

Pins of soil moisture sensor, relay and Arduino board was stated at the first part of the command where it shows A0 soil moisture pin and 13 as relay pin. The data rate was set to 9600 bps depending on the reaction time of the Arduino. The output was set to either the relay will switch on the motor pump or switch the motor pump off. When relay is at LOW, the relay will switch the pump off while when the relay is at HIGH, the relay will switch on the motor pump. The moisture value was read from pin A0 where it is the moisture sensor pin.

The value of soil output was set to a condition where when the soil moisture value is lower than 300, then the relay will be switched on and the data shows "Pump activated". While, when the value of soil moisture value is higher than 500, the relay will be switched off and the data will show "Pump deactivated"/. The analog reading value of the soil moisture was converted to percentage value through the command `moisturevalue=map (moisturevalue, 0, 1000, 0, 100)`

```
{
  digitalWrite(Relay, HIGH);
  delay(100);
  Serial.println("Pump activated");
}
if (moisturevalue > 500)
{
  digitalWrite(Relay, LOW);
  delay(100);
  Serial.println("Pump deactivated");
}
  delay(500); moisturevalue= map (moisturevalue,0,1000,0,100);
  Serial.print("Soil moisture : ");
  Serial.print(moisturevalue);
  Serial.println("%");
}
```

Figure 30: Command used (Part 2)

### **3.5.2 Hardware development**

Hardware in this project was a combination of a several circuits which were integrated together as one system. This hardware was developed to measure the main control parameter of the soil, which is the moisture content. The microcontroller circuit plays the most important role in this development since it act as the main unit to control the irrigation system.

### **3.5.3 Arduino Uno board**

Arduino is a software development environment and any of several microcontroller boards that the software environment can develop programs for. It is a microcontroller based platform with various peripheral boards. Arduino Uno board is basically an open-source electronics prototyping platform based on flexible and easy- to- use both hardware and software. Arduino Uno board shown in figure was used as it is very suitable to develop a simple and small project due to its efficiency.

The Arduino Uno board is a microcontroller board based on ATmega 328. As shown in Figure 31 is Arduino Uno board that was labelled. It has 14 digital input/ output pins, 6 analog input, a USB connection, a power jack and a reset button. It completes with every component or parts needed to support microcontroller as it can simply connect it to a computer with help of USB cable or power it with an AC to DC adapter. This board features an ATmega328 microcontroller operating at 5V and memory for storing of programs.

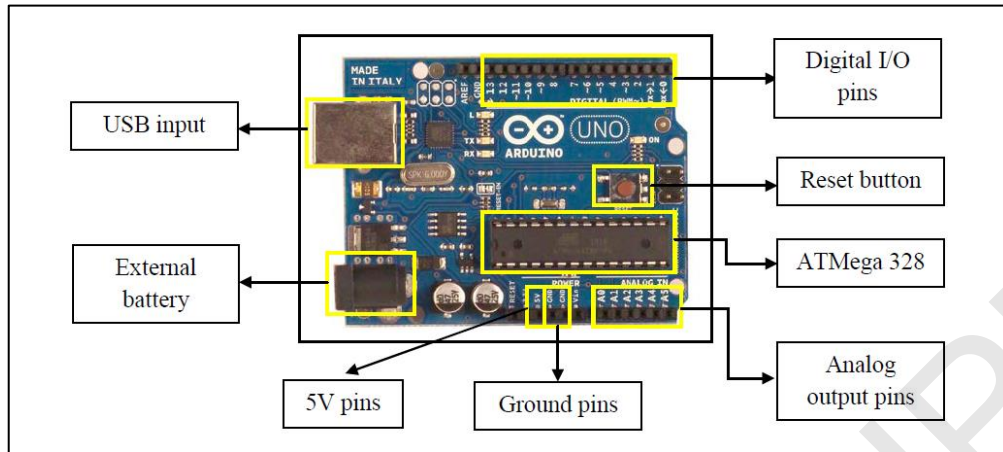

Figure 31: Arduino Uno board with labels

### 3.5.4 Soil moisture sensor

Most soil moisture sensors are designed to estimate soil volumetric water content based on the dielectric constant (soil bulk permittivity) of the soil. The dielectric constant can be thought of as the soil's ability to transmit electricity. The dielectric constant of soil increases as the water content of the soil increases. This response is due to the fact that the dielectric constant of water is much larger than the other soil components, including air. Therefore, measurement of the dielectric constant gives a predictable estimation of water content. As shown in Figure 32 is a two- legged lead soil moisture sensor that was utilized in the accomplishment of this project.

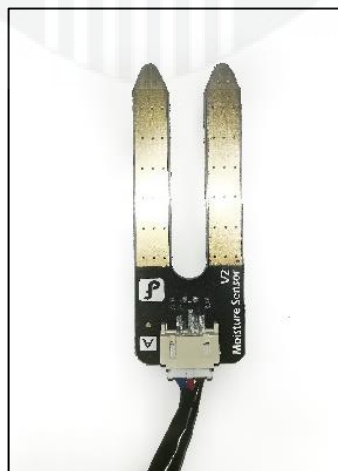

Figure 32: Two legged lead soil moisture sensor

### 3.5.5 Relay

Relay works on the principle of an electromagnetic attraction where when the circuit of the relay senses the fault current, it energises the electromagnetic field which produces the temporary magnetic field. As shown in Figure 33 is the relay module used during the accomplishment of this project. In this project, relay was used to switch on and switch off the motor pump. When the soil moisture sensor senses low moisture content, relay will energises its electromagnetic field and switch on the motor pump.

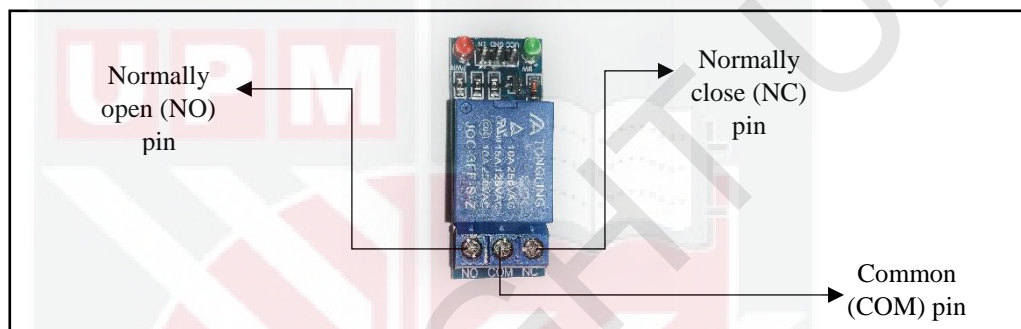

Figure 33: Relay module

### 3.5.6 Motor pump

Motor pump used was a DC powered pumps use direct current from motor, battery or solar powered to move fluid in a variety of ways. As shown in Figure 34 is the motor pump used. Motorized pumps used operates on 12V of DC power. DC powered pumps are portable and have simpler speed control and operation while the output is more energy efficient. In this project, motor pump was controlled by the relay that was depending on the soil moisture level indicated by soil moisture sensor.

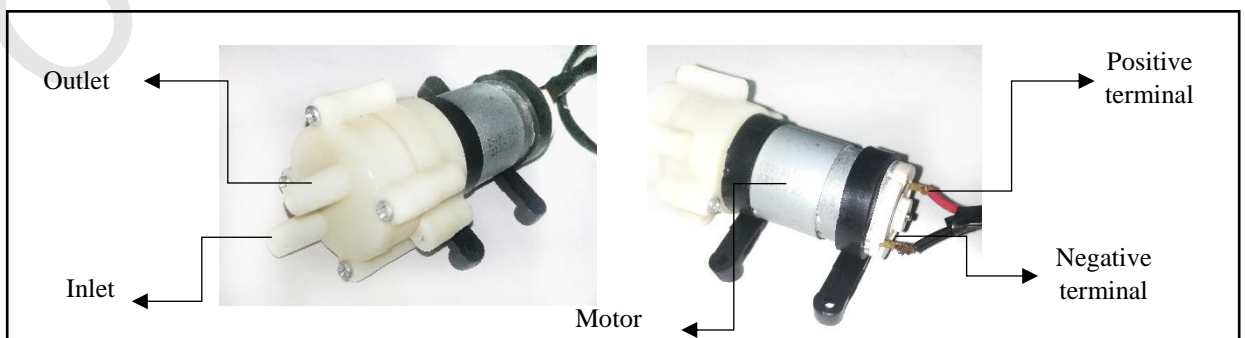

Figure 34: Front and backside of motor pump

### 3.5.7 Solar panel

Solar charge controller was connected to solar panel, motor pump and battery. There are positive and negative terminal that needed to be taken into consideration. The image of positive and negative terminal is at the back side of solar panel where the wires are connected to other components. Figure 35 shows the backside of solar panel and positive and negative terminal. The solar charge controller connections are shown in Figure 36.

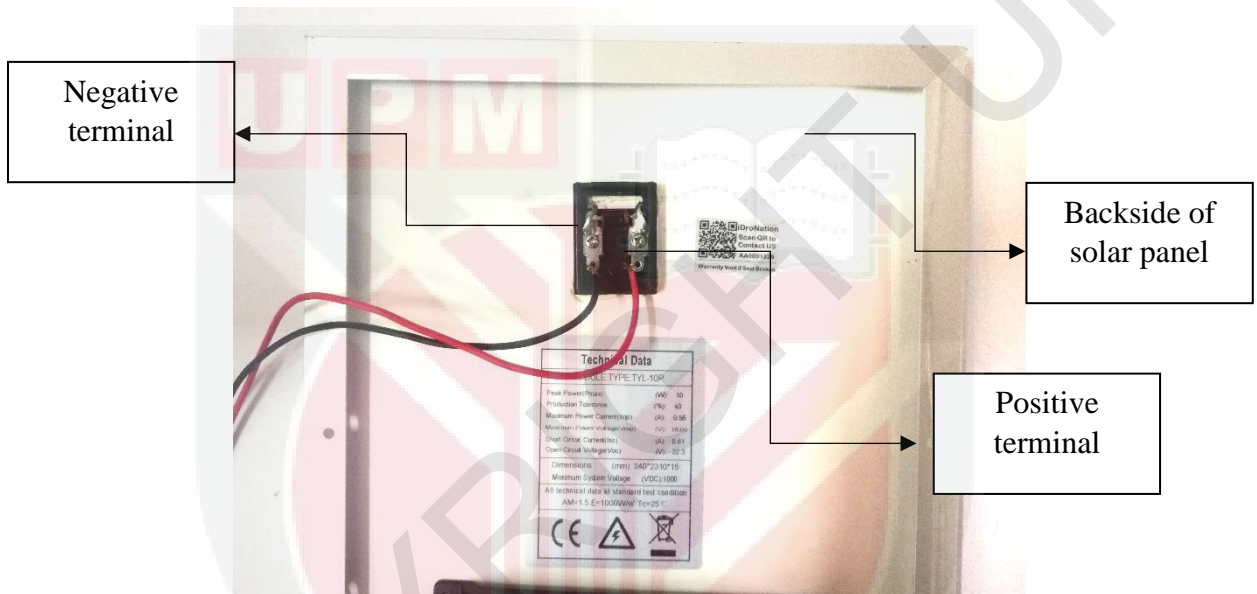

Figure 35: Positive and negative terminal

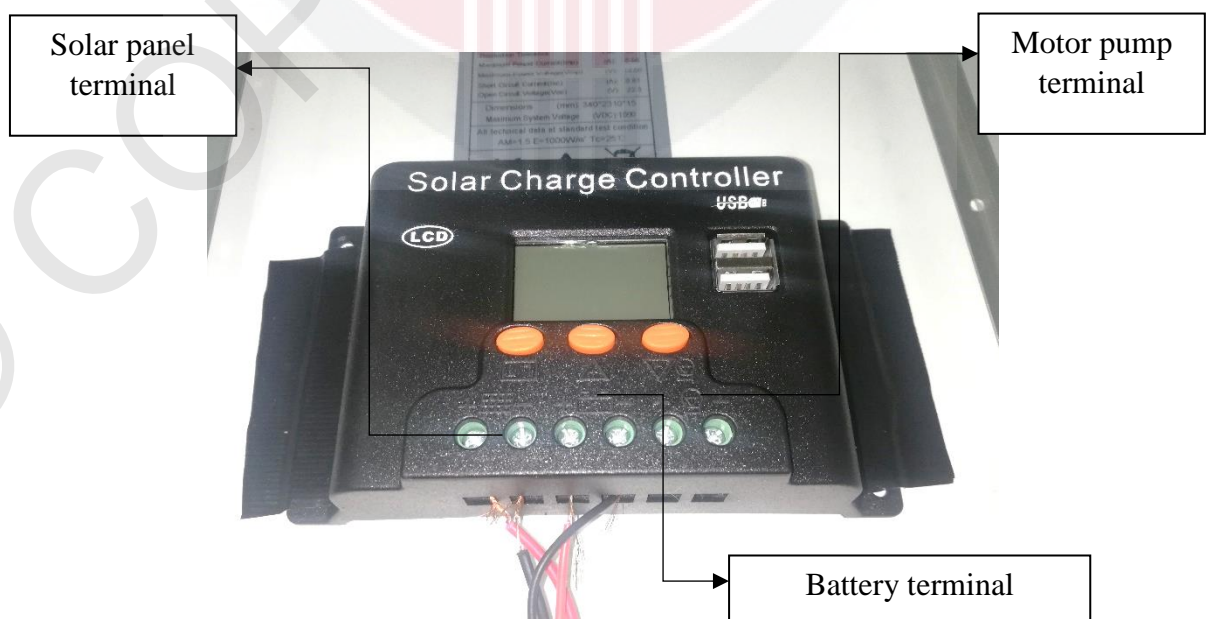

Figure 36: Solar charge controller

## CHAPTER 4

### RESULTS AND DISCUSSION

#### 4.1 Introduction

As mentioned in Chapter 1, the main objective of this research is to develop a solar powered motor pump operating automatically by moisture level sensor. A solar powered assisted by soil moisture sensor has been developed to facilitate the watering task. The project was run at an open space where sunlight was sufficient to be supplied to the solar panel. The irrigation system was equipped with a soil moisture sensor which functioned to sense the moisture of the soil.

#### 4.2 Watering System Relay

The main components of this watering system are Aduino Uno board which is already equipped with the ATmega 328, soil moisture sensor and a relay. The system has been programmed by using Arduino sketch environment software. The command is uploaded to the controller so that the sensor which acts as the input sources will send the soil moisture level to the microcontroller. When the microcontroller receives the inputs, it will send the signals to the relays as the outputs of the system. Relay will activate the motor pump according to the program command.

### 4.3 Tabulated Data for Irrigating Time

Sensor Value Description	
0 - 300	Dry Soil
300 - 700	Humid Soil
700 - 950	In Water

Table 1: Sensor value description

As shown in [wiki.dfrobot.com](http://wiki.dfrobot.com), the sensor value description shows the output reading in 12 bit value in ASCII format ranging from 000 to 1023. The moisture sensor probes pass current through the soil and then it reads the resistance to get moisture level. More water makes the soil conduct electricity easier which is lower resistance while dry soil conduct electricity poorly which is more resistance generated.

Moisture Capacity for Peat Soil (%)	
40 – 60	Low
60 – 80	Middle
80 – 100	High

Table 2: Moisture Capacity for Peat Soil

The sensor value will be converted by the coding that was compiled in the microcontroller. For peat soil, the optimum value for moisture level is 70%. As shown in table 3, the pump was switched on when the soil moisture reaches 40%. Water will be irrigated to intended soil or plants in order for it to reach the optimum moisture level

Time (hr)	Sensor Value	Moisture Content (%)	Solar Voltage (V)	Pump
1000	300	40	13.0	On
1300	300	40	12.6	On
1500	300	40	12.2	On
1700	300	40	12.0	On

Table 3: Data tabulation

#### 4.4 Comparison of Automated Solar Powered Watering System and Electric Power Supply Dependent Watering System

Since the tariff is given in RM/ kWh (kilowatt hour), therefore the formula to convert the watt and hour into kWh is by the formula:

$$\frac{W \times \text{hrs}}{1000} = \text{kWh}$$

Equation 1: Electricity rate in kilowatt hour (kWh)

While the value for watt (W) can be calculated using formula:

$$\text{Volt (V)} \times \text{Ampere (A)} = \text{W}$$

Equation 2: Electricity rate in Watt (W)

Raymond (2016) shows that electricity usage cost and charges can be calculated using equation 1 and equation 2. The specification of the motor pump used is shown in Appendix B, where for calculation purpose, 12V DC and 0.7A operating rate were used. The time taken for the test run of the watering system took 24 hours. It is shown in Table 3 that the peak time for watering to be done is in the afternoon.

#### 4.4.1 Electric Power Supply Dependent Watering System

Electricity rate of the motor pump in Watt:  $12V \times 0.7A = 8.4 W$

Electricity rate of the motor pump in kWh:  $\frac{8.4 W \times 24 \text{ hrs}}{1000} = 0.202 \text{ kWh}$

Electricity rate of the motor pump in kWh/ month:  $0.202 \text{ kWh} \times 30 \text{ days} = 6.06 \text{ kWh}$

As the electricity supply is from TNB, therefore the price that needed to be paid for every usage are set by TNB. Figure 35 shows the current rate of electricity tariff summarized by TNB Berhad.

TARIFF CATEGORY	UNIT	CURRENT RATE (1 JAN 2018)
<b>Tariff A - Domestic Tariff</b>		
For the first 200 kWh (1 - 200 kWh) per month	sen/kWh	21.80
For the next 100 kWh (201 - 300 kWh) per month	sen/kWh	33.40
For the next 300 kWh (301 - 600 kWh) per month	sen/kWh	51.60
For the next 300 kWh (601 - 900 kWh) per month	sen/kWh	54.60
For the next kWh (901 kWh onwards) per month	sen/kWh	57.10
The minimum monthly charge is RM3.00		

Figure 37: Tariff rates prices according to TNB website

If the pump need to be operating for 24 hours daily for a month (30 days), therefore, according to tariff rates stated by TNB, the electricity consumed will be about 6.06 kWh. Therefore, to run a motor pump for 24 hours daily in a month it costs 132.11 cents per month. If there were about 10 motor pump used, about 1321.10 cents (RM 13.21) is spent for a month. Although the value seems small, if accumulated for a longer time, the amount of money saved for electric bill consumption would be larger.

#### 4.4.2 Automated Solar Powered Watering System

Electricity rate of the motor pump in Watt:  $12V \times 0.7A = 8.4 W$

Electricity rate of the motor pump in kWh:  $\frac{8.4 W \times 0.67 \text{ hrs}}{1000} = 0.0057 \text{ kWh}$

Electricity rate of the motor pump in kWh/ month:  $0.0057 \text{ kWh} \times 30 \text{ days} = 0.171 \text{ kWh}$

If the pump was to be run for 0.67 hours (40 minutes) daily for a month (30 days), therefore, according to tariff rates stated by TNB, the electricity consumed will be about 0.171 kWh. Therefore, to run a motor pump for 24 hours daily in a month it costs 3.73 cents per month. If there were about 10 motor pump used, about 37.30 cents is spent for a month. This shows that automated watering system is reducing operation cost for about 97%.

Usage of solar powered watering system will cause the value of 3.73 cents for a motor pump to be free of charge as the solar energy that was converted into the battery will be supplying power to the motor pump. Solar energy supplied are reliable as it could supply power to the motor pump for 24 hours.

However, solar is not necessarily can be used for irrigation. It can be used to supply power to other electric components such as lights, ventilations, fans or vacuums. The usage of solar energy could be very beneficial and cost reducing over the time.

## CHAPTER 5

### CONCLUSION AND RECOMMENDATION

#### 5.1 Conclusion

A practical and economical watering system to ease the job of plants irrigation has been developed. The solar powered watering system has been proven working successfully during the completion of the project.

The soil was irrigated according to the soil moisture needs through the soil moisture content indicated by the soil moisture sensor. However, the amount of water irrigated was not recorded throughout the whole process as the system was set to only irrigate the plants/ soil until it reaches optimum soil moisture level for peat soil.

#### 5.2 Recommendations

1. The growth of the plants should also be recorded in order to show the effectiveness of the system.
2. For the improvement of the reliability of this project, it is recommended to use more than one sensor and placing them at different spots in the soil.
3. This system could be improved by considering the amount of water irrigated to the soil in order to know the level of efficiency of the water.

## REFERENCES

AgInnovators. (n.d.) Water Pumps: The Unrecognized Mainstay of Agriculture. *Solar Powered Pumping Initiative*. Retrieved from <http://www.aginnovators.org.au/initiatives/energy/information-papers/understanding-water-pumps>. Accessed on 26<sup>th</sup> October 2018.

Agriculture Information Bank (2015). Introduction to Soil Science- Soil Moisture. Retrieved from <http://www.agriinfo.in/?page=topic&superid=4&topicid=274>. Accessed on 26<sup>th</sup> October 2018.

Al Abdelkerim, MMR Sami Eusuf, MJE Salami, Ajibade Aibinu and Muhammad Abu Eusuf (2013). Development of Solar Powered Irrigation System. *IOP Conference Series: Materials Science and Engineering* (p.1). Accessed on 26<sup>th</sup> October 2018.

Amy Rodriguez (n.d.) The Advantages of Irrigation Systems. *Home Guides | SF Gate*, Retrieved from <http://homeguides.sfgate.com/advantages-irrigation-systems-43960.html>. Accessed on 26<sup>th</sup> October 2018.

Amy Rodriguez (n.d.). What Are the Benefits of Self-Watering Planters? *Home Guides SF Gate*. Retrieved from <http://homeguides.sfgate.com/benefits-selfwatering-planters-38604.html>. Accessed on 26<sup>th</sup> October 2018.

Balasubramanian Viswanathan, (2017) Chapter 7- Solar Energy: Fundamentals. *Energy Sources Fundamentals of Chemical Conversion Processes and Applications*. Pp 139- 147. Accessed on 1<sup>st</sup> June 2019.

Brian Francis Towler (2014) Chapter 8- Solar Power: The Future of Energy. Pp 161- 185. Accessed on 1<sup>st</sup> June 2019.

Bulent Eker (2005) Solar Powered Watering Pumping Systems. *Trakya University Faculty of Agriculture- Agricultural Machinery. Trakya Journal of Science*, Vol.3, pp. 7- 11. Accessed on 26<sup>th</sup> October 2018.

Chee Loong Wong, Juneng Liew, Zulkifli Yusop, Tarmizi Ismail, Raymond Venneker and Stefan Uhlenbrook. Rainfall Characteristics and Regionalization in Peninsular Malaysia Based on a High Resolution Gridded Data Set. *Water*, 8(11), 500. Accessed on 26<sup>th</sup> October 2018.

Christopher Teh Boon Sung (2012). Electricity from Solar Energy in Malaysia: Clean, Renewable and Abundant Energy Source, So What's the Problem? *Extraordinary Minds Discuss Ideas*. Accessed on 26<sup>th</sup> October 2018.

DFRobot (n.d.). DFRobot Drive the Future Sample Code. Retrieved from [https://wiki.dfrobot.com/Moisture\\_Sensor\\_\\_SKU\\_SEN0114\\_#target\\_0](https://wiki.dfrobot.com/Moisture_Sensor__SKU_SEN0114_#target_0) . Accessed on 1<sup>st</sup> June 2019.

Electricity Tariff Schedule (2014). Schedule 1 Tariff H1, Schedule 1 Tariff H2. Accessed on 26<sup>th</sup> October 2018.

Elsevier Inc. (2007). Section 3- Sealed Nickel- Cadmium Cells and Batteries. *Rechargeable Batteries Applications Handbook. EDN Series for Design Engineers*. Pp 35- 151. Accessed on 1<sup>st</sup> June 2019.

Energy Informative (n.d.) Which Solar Panel Type is Best? Mono- vs. Polycrystalline vs. Thin Film. Retrieved from <https://energyinformative.org/best-solar-panel-monocrystalline-polycrystalline-thin-film/>. Accessed on 1<sup>st</sup> June 2019.

Galco Industrial Electronics (n.d.) How Relays Work. Retrieved from <https://www.galco.com/comp/prod/relay.htm>. Accessed on 1<sup>st</sup> June 2019.

Hema Nagaraja, Reema Aswani and Monisha Malik (2012). Plant Watering Autonomous Mobile Robot. *International Journal of Robotics and Automation (IJRA)*, Vol.1, No 3, pp 152-162. Accessed on 26<sup>th</sup> October 2018.

Intermountain Tree Fruit Production Guide (n.d.) Orchard Irrigation: Soil Water Content. Retrieved from <http://www.intermountainfruit.org/orchard-irrigation/swc>. Accessed on 26<sup>th</sup> October 2018.

Isidor Buchmann (2013). Is Lithium- Ion the Ideal Battery. *The Lithium- Ion Battery*. Retrieved from [https://batteryuniversity.com/learn/archive/is\\_lithium\\_ion\\_the\\_ideal\\_battery](https://batteryuniversity.com/learn/archive/is_lithium_ion_the_ideal_battery). Accessed on 1<sup>st</sup> June 2019.

Lary Pitts (2016). Observant Global Software Platform. *Monitoring Soil Moisture for Optimal Crop Growth*. Retrieved from <https://observant.zendesk.com/hc/en-us/articles/208067926-Monitoring-Soil-Moisture-for-Optimal-Crop-Growth>. Accessed on 26<sup>th</sup> October 2018.

Malaysian National Committee of ICID (n.d.). *Malaysia ICID*. Retrieved from [http://www.icid.org/v\\_malaysia.pdf](http://www.icid.org/v_malaysia.pdf). Accessed on 27<sup>th</sup> October 2018.

Mark Clark, Glenn Acomb and Brent Philpot (2008). Florida Field Guide to Low Impact Development- Soil Moisture Sensors. *University of Florida- Program for Resource Efficient Communities*. Accessed on 26<sup>th</sup> October 2018.

Megan Ray Nichols (2017). Online Trade Magazine Alternative Energy from Solar, Wind, Biomass, Fuel Cells and More. *How Rural Areas Can Benefit from Renewable Energy*.

Retrieved from <https://www.altenergymag.com/article/2017/05/how-rural-areas-can-benefit-from-renewable-energy/26257/>. Accessed on 25<sup>th</sup> June 2019.

Mohammad Vahedi Torshizi and Atefeh Hosseini Mighani (2017). The Application of Solar Energy in Agricultural Systems. *Journal of Renewable Energy and Sustainable Development (RES D)*. Vol. 3. Issue 2. Accessed on 23<sup>rd</sup> June 2019.

Mohd Ikhwan Toriman and Mazlin Mokhtar (2012). Irrigation: Types, Sources and Problems in Malaysia, Irrigation Systems and Practices in Challenging Environments, Dr. Teang Shui Lee (Ed.), ISBN: 978-953-51-0420-9, InTech. Accessed on 26<sup>th</sup> October 2018.

Raymond (2016). How to Calculate Electricity Usage Cost and Charges. Retrieved from <https://www.raymond.cc/blog/how-to-calculate-electricity-usage-and-charges/> . Accessed on 23<sup>rd</sup> June 2019.

Rebecca Finneran and Mary Wilson (2015). Smart Watering In The Vegetable Garden. Retrieved from [https://www.canr.msu.edu/news/smart\\_watering\\_in\\_the\\_vegetable\\_garden](https://www.canr.msu.edu/news/smart_watering_in_the_vegetable_garden). Accessed on 26<sup>th</sup> October 2018.

Sharon Bewick, Richard Parsons, Therese Forsythe, Shonna Robinson and Jean Dupon (2019). 16.6: Batteries: Using Chemistry to Generate Electricity. Retrieved from [https://chem.libretexts.org/Courses/Eastern\\_Wyoming\\_College/EWC%3A\\_Introductory\\_Chemistry\\_\(Budhi\)/16%3A\\_Oxidation\\_and\\_Reduction/16.6%3A\\_Batteries%3A\\_Using\\_Chemistry\\_to\\_Generate\\_Electricity](https://chem.libretexts.org/Courses/Eastern_Wyoming_College/EWC%3A_Introductory_Chemistry_(Budhi)/16%3A_Oxidation_and_Reduction/16.6%3A_Batteries%3A_Using_Chemistry_to_Generate_Electricity). Accessed on 1<sup>st</sup> June 2019.

Tenaga Nasional Berhad (2018). Tariff Rates for Domestic Consumer. Retrieved from <https://www.tnb.com.my/residential/pricing-tariffs>. Accessed on 24<sup>th</sup> June 2019.

Vuk Radman and Milutin Radonjic (2017). Arduino- Based System for Soil Moisture Measurement. *Conference Paper: University of Montenegro*. Accessed on 26<sup>th</sup> October 2018.

Waqas Hassan and Farrukh Kamrun (2018). A hybrid PV/ Utility Powered Irrigation Water Pumping System for Rural Agricultural Areas. *Cogent Engineering* (p.2). Accessed on 26<sup>th</sup> October 2018.

Wikipedia The Free Encyclopedia (2018). Arduino. Retrieved from <https://en.wikipedia.org/wiki/Arduino>. Accessed on 26<sup>th</sup> October 2018.

Wikipedia The Free Encyclopedia (2018). Microcontroller. Retrieved from <https://en.wikipedia.org/wiki/Microcontroller>. Accessed on 26<sup>th</sup> October 2018.

Wikipedia The Free Encyclopedia (2018). Solar Inverter. Retrieved from [https://en.wikipedia.org/wiki/Solar\\_inverter](https://en.wikipedia.org/wiki/Solar_inverter). Accessed on 26<sup>th</sup> October 2018.

Wikipedia The Free Encyclopedia (2018). Solar Panel. Retrieved from [https://en.wikipedia.org/wiki/Solar\\_panel](https://en.wikipedia.org/wiki/Solar_panel). Accessed on 26<sup>th</sup> October 2018.



© COPYRIGHT UPM

## APPENDICES

### Appendix A: Relay programming

```
/*  
# the sensor value description  
# 0 ~300   dry soil  
# 300~700  humid soil  
# 700~950  in water  
*/  
  
int moisture = A0;  
int moisturevalue = 0;  
#define Relay 13  
void setup()  
{  
  Serial.begin(9600);  
  pinMode(Relay, OUTPUT);  
  digitalWrite(Relay, LOW);  
  digitalWrite(Relay, HIGH);  
  Serial.println("Reading From the Sensor ...");  
}  
void loop()  
{ moisturevalue = analogRead(A0);  
  delay(1000);  
  if (moisturevalue < 300)  
  {  
    digitalWrite(Relay, HIGH);  
    delay(100);  
    Serial.println ("Pump activated");  
  }  
}
```

```
if (moisturevalue > 500 )
{
  digitalWrite(Relay, LOW);
  delay(100);
  Serial.println ("Pump deactivated");

}
else
  digitalWrite(Relay, LOW);
  delay(500); moisturevalue= map (moisturevalue,0,1000,0,100);
  Serial.print("Soil moisture : ");
  Serial.print(moisturevalue);
  Serial.println("%");
}
```

## Appendix B: Motor Pump Specifications

### Description:

#### **R385 12V 3M DC Diaphragm Pump Micro Small Tank Aquarium Fish Bar**

Mainly used in the aquarium, experimental model, inflatable pool, car washing, watering, timing of mineral water filling etc.

### Specifications:

Working voltage: 6-12V DC  
Load operating current: 0.5-0.7A  
Maximum flow: 1-3L/Min  
Maximum head: 3 m  
Maximum suction range: 2 m  
Temperature:  $\leq 80^{\circ}\text{C}$   
Service life: 2500H  
Inlet pipe diameter: 6mm  
Size: 86 x 43mm

### Package include:

1xMini-aquarium pumping small pumps

### Details pictures:

