



**UNIVERSITI PUTRA MALAYSIA**

***STUDY ON HYDROPONIC SYSTEM FOR LETTUCE AND TOMATO  
PRODUCTION UNDER CONTROLLED ENVIRONMENT***

**LAMIN MANJANG**

**Ip  
FK 2019 74**



**STUDY ON HYDROPONIC SYSTEM FOR LETTUCE AND TOMATO  
PRODUCTION UNDER CONTROLLED ENVIRONMENT**

**By**

**LAMIN MANJANG**

**A Final Year Project Report Submitted to the Department of Biological &  
Agricultural Engineering, Faculty of Engineering, Universiti Putra Malaysia.**

**2019**

## APPROVAL SHEET

I certify that this research project report entitled “**Study on Hydroponic System for Lettuce and Tomato Production under Controlled Hydroponic Environment**” by Lamin Manjang has been examined and approved as a partial fulfilment of the requirements for the Degree of Bachelor of Agricultural and Biosystems Engineering in Faculty of Engineering, Universiti Putra Malaysia.

---

Dr. Aimrun Wayayok  
Faculty of Engineering  
Department of Biological & Agricultural Engineering  
(Supervisor)

---

Assoc. Prof. Dr. Samsuzana bt. Abd Aziz  
Faculty of Engineering  
Department of Biological & Agricultural Engineering

---

Dr. Anas b. Mohd Mustafah  
Faculty of Engineering  
Department of Biological & Agricultural Engineering

Date: June 2019

## ACKNOWLEDGEMENTS

Primarily, I would like to thank Allah (God) for being able to complete this project with success. Then, I would like to extend my immense gratitude to my supervisor, Dr. Aimrun Wayayok for his kind guidance, support and wealth of knowledge enjoyed throughout my study period. Also, I would like to recognize the efforts and valuable advices of Assoc. Prof. Ir. Dr. Norhashila bt. Hashim, my academic advisor. Again, I wish to extend my deep appreciation to all those who did help me in my undergraduate research study especially the teaching staff, the Laboratory Technicians and fellow undergraduate students in the Biological and Agricultural Engineering Department, Faculty of Engineering, Universiti Putra Malaysia.

I felt the unrestricted and unwavering love of my parents, uncles, aunties, siblings and worthy friends and remain obligated to them for their selfless assistance and kind support.

## TABLE OF CONTENT

### Contents

<b>APPROVAL SHEET</b> .....	ii
<b>ACKNOWLEDGEMENTS</b> .....	iii
<b>TABLE OF CONTENT</b> .....	iv
<b>ABSTRACT</b> .....	vi
<b>ABSTRAK</b> .....	vii
<b>LIST OF TABLES</b> .....	viii
<b>LIST OF FIGURES</b> .....	ix
<b>LIST OF ABBREVIATIONS</b> .....	x
<b>CHAPTER 1</b> .....	1
<b>INTRODUCTION</b> .....	1
<b>1.1 Background to the Study</b> .....	1
<b>1.2 Statement of the Problem</b> .....	2
<b>1.3 Aims and Objectives</b> .....	2
<b>1.4 Significance of the Study</b> .....	2
<b>1.5 Limitations</b> .....	3
<b>CHAPTER 2</b> .....	4
<b>LITERATURE REVIEW</b> .....	4
<b>2.1 Controlled Hydroponics Environment</b> .....	4
<b>2.2 Sensors</b> .....	12
<b>2.3 Humidity Sensor</b> .....	13
<b>2.4 Nutrition Plants for Hydroponics Systems</b> .....	13
<b>2.5 Nutrient Film Technique/Method</b> .....	16
<b>2.6 Summary of Literature Review</b> .....	18
<b>CHAPTER 3</b> .....	19
<b>MATERIALS AND METHODS</b> .....	19
<b>3.1 Site Location</b> .....	19
<b>3.2 Materials</b> .....	19
<b>3.2.1 Bill of quantity (BOQ)</b> .....	20
<b>3.3 Method of pump sizing or selection for hydroponic system</b> .....	22
<b>3.3.1 Manning's equation for flowrate (Q) determination</b> .....	22
<b>3.3.2 Pump size determination</b> .....	23

3.4 Methods for the NFT System .....	23
3.5 Suitable Fertilizer Mixture Rate for Lettuce and Tomato .....	30
3.5.1 Urban grower's desired leafy greens fertilizer A&B .....	30
3.5.2 Seedlings mixing guideline .....	31
3.5.3 Maturing plants mixing guideline .....	31
3.6 Maintenance and Adding Instructions .....	32
3.7 Statistical Analysis .....	33
<b>CHAPTER 4.....</b>	<b>34</b>
<b>RESULTS AND DISCUSSIONS.....</b>	<b>34</b>
4.1 Design of NFT Systems .....	34
4.1.1 Schematic design for butterhead lettuce NFT system.....	34
4.1.2 Schematic design for cherry tomato NFT system .....	35
4.1.3 Finding the flowrate (Q) .....	36
4.1.4 Determination of pump size/power (P).....	37
4.2 Most Suitable Fertilizer Mixture Rate for Lettuce and Tomato .....	37
4.2.1 The suitable fertilizer mixture rate for butterhead lettuce .....	40
4.2.2 The suitable fertilizer mixture rate for cherry tomato .....	41
4.2.3 Maturing variations for butterhead lettuce plants .....	43
4.2.4 Maturing variations for cherry tomato plants .....	44
4.3 The Need of Suitable Planting Media for the NFT Hydroponic System.....	47
4.3.1 ANOVA, Mean comparison and SPSS analyzed butterhead lettuce data .....	47
4.3.2 ANOVA, Mean comparison and SPSS analyzed cherry tomato data .....	49
4.3.3 Harvested butterhead lettuce weight variations.....	50
4.3.4 Harvested cherry tomato fruits weight variations .....	51
4.3.5 Cherry tomato stem fruits weight sustenance capacity .....	52
4.3.6 Chlorophyll content in matured butterhead lettuce leaves .....	53
4.3.7 Chlorophyll content in matured cherry tomato leaves .....	54
<b>CHAPTER 5.....</b>	<b>56</b>
<b>CONCLUSIONS AND RECOMENDATIONS.....</b>	<b>56</b>
5.1 Conclusion .....	56
5.2 Recommendations .....	58
<b>References.....</b>	<b>60</b>
<b>APPENDICES .....</b>	<b>61</b>

## ABSTRACT

Hydroponics commonly incorporates crops farming deprived of chemical fertilizers and soil utilization, it decreases crop diseases, hazard of pest and utilized for yield creation in controlled cultivating structure. With regard to the existing hydroponic systems, the cultivator can only show essential parameters such as humidity, water level, nutrients and light intensity using smart monitoring devices of the NFT system. Here we designed a Nutrient Film Technique system with UPVC pipe, wood, net protection, pH meter, EC meter, media (perlite, clay pebbles and coco fiber), for growing tomato and lettuce in a close system environment, which includes determination of pipe size, flowrate, angle of pipe degree and pump size, to study the interaction of the nutrient mixing rate and the growing media and the need of suitable planting media for hydroponic system for holding the mixture of fertilizer content in the different media. We found the results of flowrate,  $Q$  to be 117.9 L/hr through a 3” (7.62 cm) UPVC pipe diameter and a 90 degree elbow joint with pump size/power of 0.193 watt. The weekly addition of supplement A&B for butterhead lettuce was 600 ml meaning 86 ml daily and for cherry tomato required 2100 ml meaning 300 ml per day of nutrient A&B which is sustainable. The pH and EC for butterhead lettuce were in a range of 5.5 - 6.5 and 0.8 - 2.0 mS/m while the pH and EC for cherry tomato ranges from 5.5 - 6.5 and 2.0 - 5.0 mS/m. The One-way ANOVA, Mean comparison and SPSS plant height variations between groups for butterhead lettuce and cherry tomato shows a significance of 0.004 ( $p < 0.05$ ) and 0.472 ( $p > 0.05$ ) respectively. Clay pebble media recorded the highest fruits yield and weight, its stem can withstand up to 173.6g, also, followed by perlite media and the least was recorded by the coco fiber media with lowest stem holding capacity fruits weight of 36.5g.

Keywords: Hydroponics, pH Meter, Electrical Conductivity Meter, Nutrient Film Technique

## ABSTRAK

Hydroponiks biasanya menggabungkan pertanian tanaman yang dilucutkan baja kimia dan penggunaan tanah, ia mengurangkan penyakit tanaman, bahaya perosak dan digunakan untuk penciptaan hasil dalam struktur penanaman terkawal. Berkenaan dengan sistem hidroponik yang ada, penanam hanya boleh menunjukkan parameter penting seperti kelembapan, paras air, nutrien dan intensiti cahaya menggunakan peranti pengawasan pintar sistem NFT. Di sini kami merancang sistem Teknik Filem Nutrisi dengan paip UPVC, kayu, perlindungan bersih, meter pH, meter EC, media (perlite, batu tanah dan serat coco), untuk pertumbuhan tomato dan salad dalam persekitaran sistem yang rapat, yang merangkumi penentuan paip saiz, kadar aliran, sudut gelung paip dan saiz pam, untuk mengkaji interaksi kadar pencampuran nutrien dan media yang semakin meningkat serta keperluan media penanaman yang sesuai untuk sistem hidroponik untuk memegang campuran kandungan baja dalam media yang berbeza. Kami mendapati hasil aliran aliran, Q menjadi 117.9 L / jam melalui diameter paip UPVC 3 "(7.62 cm) dan satu siku 90 darjah bersama dengan saiz / kuasa pam 0.193 watt. Tambahan mingguan suplemen A & B untuk selada butterhead adalah 600 ml yang bermaksud 86 ml setiap hari dan untuk tomato ceri diperlukan 2100 ml yang bermaksud 300 ml sehari nutrisi A & B yang mampan. PH dan EC untuk selada butterhead berada dalam lingkungan 5.5 - 6.5 dan 0.8 - 2.0 mS / m manakala pH dan EC untuk tomato ceri adalah antara 5.5 - 6.5 dan 2.0 - 5.0 mS / m. The ANOVA One-way, perbandingan min dan variasi ketinggian tanaman SPSS antara kumpulan untuk salad selasih butterhead dan tomato ceri menunjukkan kepentingan 0.004 ( $p < 0.05$ ) dan 0.472 ( $p > 0.05$ ) masing-masing. Media kerikil tanah liat mencatatkan hasil buah dan berat tertinggi, batangnya boleh bertahan sehingga 173.6g, diikuti oleh media perlit dan paling kurang dicatatkan oleh media serat coco dengan kapasiti pegangan batang paling rendah sebanyak 36.5g.

Kata kunci: Hydroponiks, Meter pH, Meter konduktiviti elektrik, Teknik Filem Nutrien

## LIST OF TABLES

<b>Table 3.1. Materials for the hydroponic NFT system. ....</b>	<b>19</b>
<b>Table 3.2. Bill of Quantity (BOQ).....</b>	<b>20</b>
<b>Table 3.3. Methods of NFT fabrication and complete setup processes. ....</b>	<b>25</b>
<b>Table 4.1. Weekly variations for butterhead lettuce maturing plants. ....</b>	<b>43</b>
<b>Table 4.2. Weekly variations for cherry tomato plants. ....</b>	<b>45</b>
<b>Table 4.3. Showing the significance value between groups and within groups through height comparison using one-way ANOVA for butter head lettuce. ....</b>	<b>48</b>
<b>Table 4.4. Demonstrated that perlite media was significant from clay pebble and coco fiber media which showed no significance difference for butterhead lettuce. ....</b>	<b>48</b>
<b>Table 4.5. Appearing no significance difference between groups and within groups through height comparison utilizing one-way ANOVA for cherry tomato. ....</b>	<b>49</b>
<b>Table 4.6. Illustrated that perlite, clay pebble and coco fiber media which appeared no significance difference falls in the same group for cherry tomato. ....</b>	<b>50</b>

## LIST OF FIGURES

<b>Figure 2.1. Hydroponic Monitoring and Management Physical Plan (Crisnapati et al., 2017).</b> .....	7
<b>Figure 2.2. Tubing plan for the hydroponic framework (Velazquez et al., 2013).</b> 9	
<b>Figure 2.3. Mechanized pH controller framework (Saaid et al., 2015).</b> .....	12
<b>Figure 2.4. Common Design of Computerized Hydroponics Sustenance Plants Frameworks (Eridani et al., 2018).</b> .....	15
<b>Figure 3.1. Maturing Plants Mixing Guidance.</b> .....	31
<b>Figure 4.1. NFT System Design for Butterhead Lettuce.</b> .....	35
<b>Figure 4.2. NFT System Design for Cherry Tomato.</b> .....	36
<b>Figure 4.3. Butterhead Lettuce Nutrient A&amp;B Amount Used.</b> .....	38
<b>Figure 4.4. Cherry Tomato Nutrient A&amp;B Amount Used.</b> .....	39
<b>Figure 4.5. Butterhead Lettuce pH Meter Readings.</b> .....	40
<b>Figure 4.6. Butterhead Lettuce EC Meter Reading.</b> .....	41
<b>Figure 4.7. Cherry Tomato pH Meter Readings.</b> .....	42
<b>Figure 4.8. Cherry Tomato EC Meter Readings.</b> .....	43
<b>Figure 4.9. Weight variations in harvested butterhead lettuce.</b> .....	51
<b>Figure 4.10. Average Weight Variations in Harvested Cherry Tomato Fruits.</b> 52	
<b>Figure 4.11. Stem cherry tomato fruits weight sustenance.</b> .....	52
<b>Figure 4.12. Chlorophyll content in matured butterhead lettuce leaves.</b> .....	54
<b>Figure 4.13. Chlorophyll Content in matured butterhead lettuce leaves.</b> .....	55

## LIST OF ABBREVIATIONS

NFT	Nutrient Film Technique
EC	Electrical Conductivity
PVC	Polyvinyl Chloride
PPM	Parts Per Million
m	Meter
kg/m <sup>3</sup>	Kilogram per cubic metre
H	Piezometric height of water
$\rho$	Density of the liquid
Q	Flowrate
P	Power
W	Watt
m <sup>3</sup> /s	Cubic metre per second
ml	Millilitre
mS/m	MilliSiemens per meter
g	Gram
Sig.	Significance
OSHA	Occupational Safety and Health Administration
IARC	International Agency for Research on Cancer
ACGIH	Association Advancing Occupational and Environmental Health
SPSS	Statistical Package for the Social Sciences
L	Litre
hr	Hour
cm	Centimeter
mm	Millimeter

# CHAPTER 1

## INTRODUCTION

### 1.1 Background to the Study

Hydroponics commonly incorporates crops farming deprived of chemical fertilizers and soil utilization, it decreases crop diseases and hazard of pest. Plant growth nutrients needed are provided in nutrient solution forms through an accurate combination of essential plant's requirement modules. The hydroponic structure is constructed in a secure surrounding, the crops that mature in the structure, possesses the possibility to improve when deprived of sunlight. As a result, avoids the growth of algae in crops nutrient solution which are wide-open (Umamaheswari et al., 2017).

Hydroponics is utilized for crop production in environmentally-controlled farming structure, for instance, plant factories growing leafy vegetables for example lettuce, tomato, basil and spinach. Growing media is one of the noteworthy features in nurturing activities for the motive that it will standardize the attainment rate of the developing plant that eventually disrupts the creation. Benefits of hydroponics structures contain all the more efficient land use, higher quantity, abundance harvests and distinction of production, cleaner, progressively feasible use of water and fertilizers, less complex in bug and disease control. Electrical conductivity (EC) in nutrients, changes in pH, air temperature, water temperature and light force variation, prevent improvement of the hydroponics plants, for most vegetable crops. If plant improvement is not watchfully observed routinely and sporadically, it will distract the vegetable yields. To convey good vegetable harvests, agriculturists should consistently pay attention to factors such as fertilizer content, water temperature, pH adjustment,

EC sustenance, light intensity, air temperature variation inside the hydroponic planting medium (Siregar et al., 2018).

## **1.2 Statement of the Problem**

With regard to the existing hydroponic systems, the cultivator can only show essential parameters such as humidity, water level, nutrients and light intensity using smart monitoring devices. There is no further study made on incorporating the design of the Nutrient Film Technique (NFT) system for growing tomato and lettuce which includes pipe size, flowrate, angle of pipe degree and pump size to know the interaction of the nutrient mixing rate and the growing media. Also, the need for suitable planting media for hydroponic system for holding the mixture of fertilizer content in the different media.

## **1.3 Aims and Objectives**

The main objective is to study the interaction of the nutrient mixing rate and the growing media.

The specific objective are:

- To design the NFT system for growing tomato and lettuce which includes pipe size, angle of pipe degree, flowrate and pump size.
- To study the most suitable fertilizer mixing rate for lettuce and tomato.
- To study the need of suitable planting media for hydroponic system for holding the mixture of fertilizer content in the different media.

## **1.4 Significance of the Study**

The NFT system design for growing tomato and lettuce which includes pipe size, angle of pipe degree, flowrate and pump size, the study of the interaction of the nutrient mixing rate and the growing media which can make it easier to determine the most

suitable fertilizer mixture rate for lettuce and tomato growth. Moreover, the need of suitable planting media for hydroponic system for holding the mixture of fertilizer content in the different media is determined.

### **1.5 Limitations**

- The study was based simply on a minor scale process not of a bulk nor greater scale process or cultivation.
- Each plant in a hydroponics system is sharing the precise same nutrient, illnesses and pests can easily affect each plant.
- Cultivators require ability and information to preserve ideal production in commercial applications.
- Plants respond faster to changes within the environment, however, if this change is for the worst, plants will rapidly respond to it; appearing signs of insufficiency or inconvenience.
- Hot climate and constrained oxygenation may constrain generation and can result in misfortune of crops.

## CHAPTER 2

### LITERATURE REVIEW

#### 2.1 Controlled Hydroponics Environment

Based on the considerations of the built up structure, it enable the growth of different types of crops under a solitary regulator. Essential additions for the crops are delivered based on the inputs derived from the used water level sensor and the used pH sensor. The nutrient and water transmission to the different arrangements is checked and controlled at standard time breaks. A convincing algorithm has been suggested for coordinating every one of the capabilities. Motorizing hydroponics system augments the efficiency and limits hard labor. The plants made underneath this system is investigated, usually discovered that these plants build up a section quicker with least essential of nutrients. The inadequacies of the present structure like growth of a solitary kind of crop inside the entire system have been overcome. It was found that they were clean with least substance constituents, utilizing needed water and nutrients. In addition, the cropping price is minimal on concern of its rewards. Hereafter this model inspires working of a different method in the direction of farming that is environmentally friendlier and effective on judgement with future methods (Umamaheswari et al., 2017).

At present, hydroponics is mainly used in agricultural production. Plants need watering and fertilization regularly. They proposed a study to regulate the necessary conditions required for the plant to grow hydroponically and also cultivators may control the agriculture remotely using Internet of Things (IoT). Unluckily, existing automatic control system is not stable, some unexpected errors occur especially it is hard to realize the remote monitoring and control. For its features, the system is a strong candidate for agriculture uses. For now, they have an idea that the device of hydroponic

can be linked with social communication platform, which can realize a magnificent dream that people can network with their hydroponic plants online through a mobile terminal (Siregar et al., 2018).

To make regulator gadget in surging enhancements of the hydroponics plant normally by means of Arduino microcontroller constrained by cell phone. Microcontroller Arduino Uno normally used to regulate the surge of enhancement in nutrient solution flow with if else logic, besides, it could direct data of temperature and fluid dimension round the plant to cell phone android user of the hydroponic plants. The elevation of the nutrient solution (water) is sensed by the Ultrasonic sensor HC-SR04 which is also distinguished by the sensor of temperature LM35. Sensor data will advance into Arduino Uno and appeared Liquid Crystal Display (LCD) by then through remote consistency (WIFI) ESP8266 element that pass on the height of the nutrient solution and temperature round the plants cell phone Android. In their tests, Sihombing et al. (2018) gave the idea that mixture of liquid and enhancements or nutrients was subsequently moved to plants established in hydroponic cylinders. The water mark is retained up to 6 cm in hydroponics cylinders since the structure will exhaust water occasionally if there is a liquid insufficiency. They suggested and recommended that future research can observe sharpness dimensions of pH solution, viscosity and oxygen consistency and other different features. Their motorization structure is on a little measure, it is foreseen to be made to shape it on a progressively broad scale. Their project, the structure relies on Android as an ongoing information board. It is foreseen in future research the device and structure to be able to make information board with other working systems that could remain used by way of a standard structure or system. This examination considered features that another hydroponics methodology is the Deep Water Culture (DWC). With the aid of this technique, plants roots will

consistently be immersed in the nutrient water solution that holds oxygen and supplements. Regardless of the way that this technique physically regulates pH of water, it could give dreadful effect to creating of plants. In their research, water pH content in nutrient was normally ensured through microcontroller estimated by device, the time pH content started to transform and the effects of pH adjuster solution to the water solution are chosen and the research similarly concentrated on the capability that the scheme can regulate the pH value in liquid solution for DWC (Saa'id et al., 2015). The hydroponics system has different dense sorts and could defeat land complications in city areas, NFT is one of them. Their hydroponics system requested explicit consideration in controlling water content, temperature of water, destructiveness or corrosiveness nutrient solution. This work focused on influencing a hydroponic to develop organization structure that could monitor higher densities of nutrient solution, water temperature, water level and the sharpness pH of a nutrient solution using devices or sensors connected and related to the microcontroller through a website. The upcoming work of this study is to gather normal data, which got devices or sensors and implanting an artificial intelligence that makes the monitoring and management of hydroponic system run automatically (Crisnapati et al., 2017). Figure 2.1 shows the hydroponic monitoring and management physical plan.

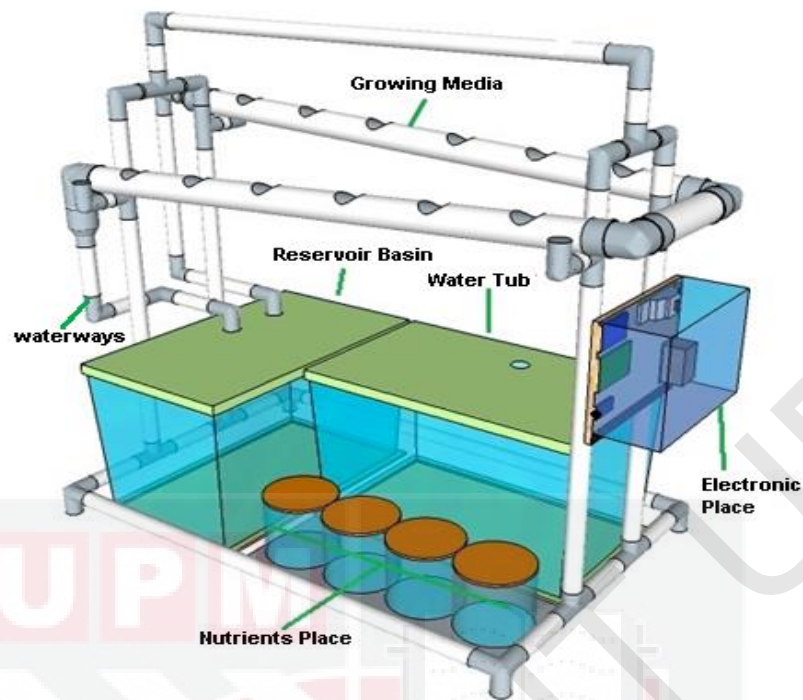

**Figure 2.1. Hydroponic Monitoring and Management Physical Plan (Crisnapati et al., 2017).**

To be able make it more straightforward to put the modules, the physical arrangement of the NFT hydroponics farm organization structure was arranged as in Figure 2.1. The essential material of the Polyvinyl Chloride (PVC) tube gadget which measures 3” diameter implanting media and  $\frac{3}{4}$ ” diameter PVC to stream nutrient or supplement solution. The tank with a plastic container which functions to house any mixture of nutrient solution in liquid. This study observe the arrangement and utilization of the modified hydroponic nutrient film technique at a model balance using mean Total Dissolve Solids (TDS) devices. The examination uncovered that, this system can observe the dimension of EC in nutrient solution ICITACEE 2017 174 using TDS device in parts for every million unit. This model scale hydroponic nutrient film technique structure may pass on nutrients mechanically so the nutrient content inside the solution is not exactly the least limit of 800 ppm. The exactness of the TDS device dependent on the power element to parts per million change procedure is 97.8%. The

software or program established may perhaps regulate the hardware schemes rendering to the outcomes of the scheme prerequisite as acknowledged. The design and application of the nutritional automation schemes on NFT hydroponics may well meet all the efficient necessities as intended (Eridani et al., 2018).

In this examination, they instigated the fuzzy logic to regulate the pH and EC state of the hydroponics nutrients film technique framework in IoT system condition. In using IoT contain of mechanism to mechanism, wireless network device, data logger and actuator siphon, are capable of slightly monitoring and watching all parameters from side to side web mastermind that could be associated with dissipated range. Factor of EC and pH are kept up in range portrayed concerning the given input information. Ideal time to recuperate the EC and pH from external range to inside the ideal specified range is just about 15 minutes. In light of their tests, by including 1 ml of acid solution in increasing pH in the involvement container with capacity of liquid of 10 litre can elevate  $\text{pH} \pm 0.01$  and by including 1 ml corrosive arrangement in decreasing pH could diminish  $\text{pH} \pm 0.015$ . Though for the EC, by including 1 ml of nutrient solution A and 1 ml of nutrient solution B in the socializing container with capacity of liquid 10 litre could advance  $\text{EC} \pm 0.034$ . The here and there pH regard explicitly comparing to siphon activation time, likewise with factor of electrical conductivity. The more vital the increasing or decreasing pH regard by then the more extended answer time structure to wrap up the strategy in satisfying information needed (Yolanda et al., 2017).

Study on the advances in the improvement of hydroponics framework for tomato cherry production grounded on NFT are displayed in Figure 2.2. Considerations for the nourishing hydroponics nutrient solution are the EC and the pH. Devices and molding routes were arranged and associated to monitor such considerations. The bodily water framework structure dependent on PVC pipes were outlined and offered.

Preliminary results revealed high exactness approximations on pH with a correlation constant of 0.994 for anticipated qualities and a customary deviance of 0.01 later reiterated approximations. A definitive target is the combination of the developed devices and routes into occupied mechanism nursery structure for clear, easy to use and low cost soilless culture platform (Velazquez et al., 2013). Figure 2.2 shows the tubing plan for the hydroponic framework.

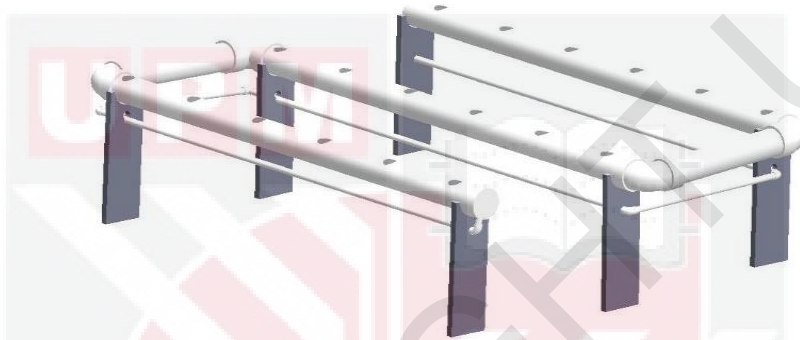

**Figure 2.2. Tubing plan for the hydroponic framework (Velazquez et al., 2013).**

Hydroponics technique of creating plants is using mineral nutrient solution in liquid, deprived of soil use. Earthly plants might be created with foundations inside the mineral nutrient solutions in a sluggish or inert medium. This system would safeguard the underlying foundations of plants persistently plunge in oxygen and liquid. Benefit of deep water culture scheme is significantly oxygenated, lower fertilizer usage, lower maintenance cost and time monitoring. Saaid et al. (2013) studied the constrained pH device where a device scrutinizes the regard of liquid with nutrient inside the reservoir and preserved to the essentials required by means of blender inside regulator. Furthermore, liquid supply is persistently held over dimension regulator which impels order to regulate liquid stream into or out from the reservoir. The liquid mark monitoring is vital to protect a required liquid mark in the reservoir. From the

exploratory test, there were variations of 5.64 ml in both alkalinity and acidity range in each pH of 0.244 and 0.312.

Andaluz et al. (2016) shows that the govern stream associated with hydroponics development which made a limit among human and machine in a permitted program letting unending checking of temperature, dampness, pH, and EC of soil over the devices retained within the alter root zone. In addition, the regulator plays out the molding sensors, actuator govern advantage for rising water, and supplement or nutrient solution and checking through a network. The ground utilization of the system is completed in a passage type nursery delineated underneath distributes of a hydroponic structure. The conduct of the structure offers the watering switch a tracking device and a database agronomist; the variables manage any kind of effect on tomatoes age and show possible healthful inadequacies, which is not viewed an infection until now in the crop. The regulator of water framework arranging efficiently, passing on the predetermined dose of liquid resources for meeting the extents of the plants, maintaining a strategic distance from remarkable estimations, other than the correct sustenance of the plant is constrained by giving the improvement a chance to lower time of the plant, grabbing and gaining essential green fruits items monthly to get abundant yield and production age yearly.

This research paper shows a convincing hydroponics enhancement nutrient solution control structure whose system considerations are improved using genetic count. To review the implementation of the planned computation, a simulated hydroponics enhancement govern structure with a nutrient content watching unit was arranged using LabVIEW. The arranged computation showed an improved gathering viability and resource usage composed to standard error work based nutrient solution control structures. The proposed system was sketched out using Matlab gadgets. For

examination dedications, a simulated hydroponics enhancement control setup was reproduced using LabVIEW with a self-contained enhancement checking unit. The suggested algorithm shown to outline way improved execution regarding mixing rate and resource use thought about standard misstep based estimation that were used in nutrient solution control. The sketched out cushy acceptance system could be advance improved to require plant's improvement compose into thought while assessing the enhancement excellence. The planned strategy could in addition be used to advance the regenerative improvement over the vegetative advancement in hydro-cultivates along these lines increase its yield commercially (Lenord and Sridevi, 2014).

The hydroponic frameworks with distribution of supplement arrangement spare water and fertilizer, but over time it is difficult to hold the wholesome adjust and control maladies that assault the roots, causing lower execution compared to frameworks where the arrangement isn't recycled. Their objective was to relate the water utilize effectiveness and supplements, as well as the abdicate in developing tomato, between open and closed hydroponic frameworks using a crop management procedure based on brief cycles, by the pruning at three clusters per plant. With the information an ANOVA was performed and means were compared utilizing the Tukey test ( $p \leq 0.05$ ). Morphological characteristics, abdicate, water utilize and fertilizers were measured. The most elevated yields were gotten with profound hydroponics ( $16.7 \text{ kg/m}^2$ ) and with closed sacks ( $15.3 \text{ kg/m}^2$ ) in a trim cycle of four months. The fertilizer reserve savings (K, Ca, N and P) in distribution frameworks with substrate was 41 % and 35 % of water in connection to the frameworks without distribution (Sánchez-Del et al., 2014).

## 2.2 Sensors

The pH liquid mark solution to the significant liquid values should be kept up ensuring plants growth cleverly. In the previous research, the green mustard was taken as a plants test and the fit run pH mark for green mustard was 6.0 - 7.5 (Saaid et al., 2015).

Figure 2.3 demonstrate a mechanized pH controller framework.

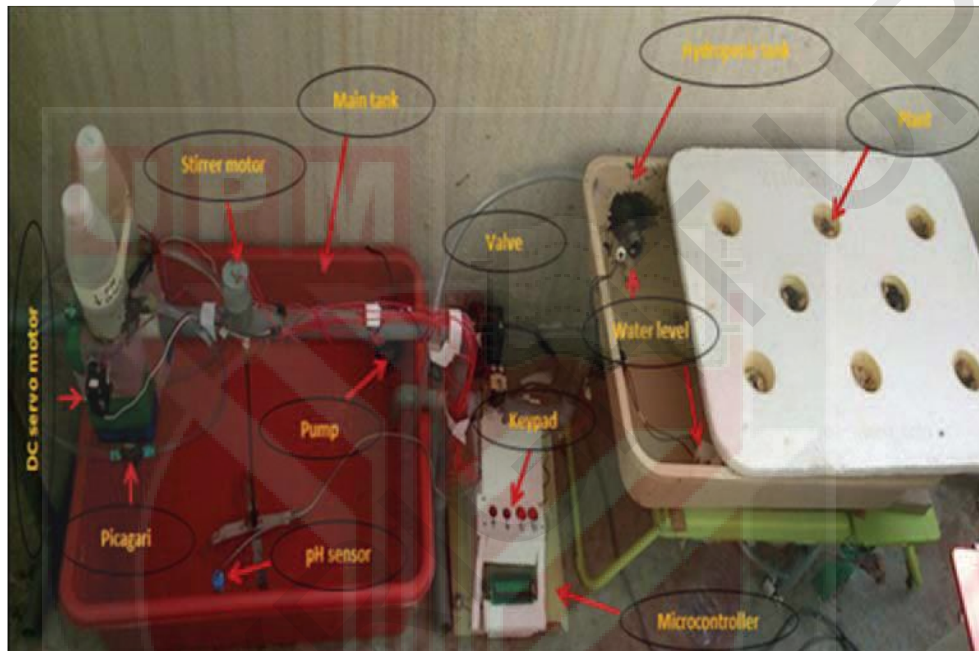

**Figure 2.3. Mechanized pH controller framework (Saaid et al., 2015).**

This structure used two tanks, the main container and hydroponic container. The situation of the hydroponic container arranged over the main container so the liquid arrangement plan inside the hydroponic container might easily to trade again into the main tank for keeping up the pH liquid mark nutrient solution after a specific period as indicated in Figure 2.3. That way, to trade the liquid plan into the main container was finished by solenoid regulator. Standing the pH specialist stirrer and measurer, the PVC channels was used.

For a perfect building up, the nutrient solution for tomato cherry vegetables ought to be in pH range of 5.5 - 6. Device picked to screen pH in hydroponics arrangement

depends on molecule explicit cathodes. Structure of pH, an EC was introduced in a PVC channel (6 x 8 x 20 mm). The conductivity gives information nearly the full salinity inside the nutrient solution. The ideal EC for tomato cherry nutrient solution is in the scope of 1.8 to 3 mS/m (milliSiemens per meter). Standards outside this range in the conductivity dimension would symbolize a nutritional unevenness. The EC route was primarily verified by means of static value resistors, later was assessed with dissimilar concentrations of salt solution. In both cases the obtained measurements were acceptable (Velazquez et al., 2013).

### **2.3 Humidity Sensor**

A humidity sensor or hygrometer senses, measures the relative dampness in the air. It thus estimates mutually moistness and examine temperature. Similar moisture is the proportion of solid suddenness in the air to the most raised total of clamminess that can be acknowledged at that examined temperature. The more sizzling the air temperature is, the more clamminess it can hold. Moisture/globules sensors use capacitive estimation, which relies upon electrical capacitance. Electrical limit is the limit of two contiguous electrical conveyors to frame an electrical field between them (Siregar et al., 2018).

### **2.4 Nutrition Plants for Hydroponics Systems**

Modified hydroponic framework houseplant is placed in an exceptional hollow and the enhancements are directed explicitly to the hydroponics origins at some random time. The microcontroller Arduino Uno regulate the surge of liquid nutrient on the basin automatically, microcontroller can be organized from Android cell phone. Running this project, the program segment has been implemented in the framework. The microcontroller Arduino Uno is used progressively to set cautions on enhancement siphons. At the point when the alarm is on enabled, relay will be impelled

and the enhancement siphon will drain the nutrient solution on the hydroponic plants. At the point as soon as the alarm was disengaged, exchange would be quenched and the nutrient siphon will end giving. To back this endeavor, they arranged a virtuino presentation on cell phone Android that assists to see the liquid mark and temperature round the hydroponic plants. At some point as of late beginning the arrangement of a virtuino presentation, it first offers the data storage consuming topographies at thingspeak.com. Figure 2.4 demonstrated that the idea is given direct to the hydroponics stream system starting from the area of a region device and a temperature device. The device will observe the liquid mark inside the hydroponics cylinder and temperature device to recognize room temperature. Device disclosure will be connected with a transfer related to the microcontroller harbor. At the point when the relay harbor stick is lower than the ideal stature, the liquid stream will be kept running on the liquid siphon to water the hydroponic plants. At the point when the exchange of harbor stick is high, it infers the liquid mark is over of the ideal stature, and after that the liquid siphon will end flowing liquid. Thus, the liquid transmission will stream as often as possible. To back this system, additionally the Liquid-crystal display monitor to demonstrate the date and time whenever of the strategy was used. The nutrient siphons are utilized not in a manner of speaking to stretch out water but rather to incorporate enhancements to the hydroponics cylinder. Liquid siphons are used for water appropriation and exchanges are used to coordinate the two siphons for liquid segment and exit of liquid (Sihombing et al., 2018).

The sonic device (HC - SR04) perceives the height value of nutrient solution in hydroponics vegetation by the consideration of the height of liquid (in gm) entity or unit with temperature. The LM-35 device will perceives temperature in entities of °C expand. The sonic devices will degree the different of liquid dependent on sonic

movement. Evacuate between transmit time and persuade time gets the chance to be a portrayal of the distance of the liquid. Figure 2.4 shows the common design of computerized hydroponics sustenance plants frameworks.

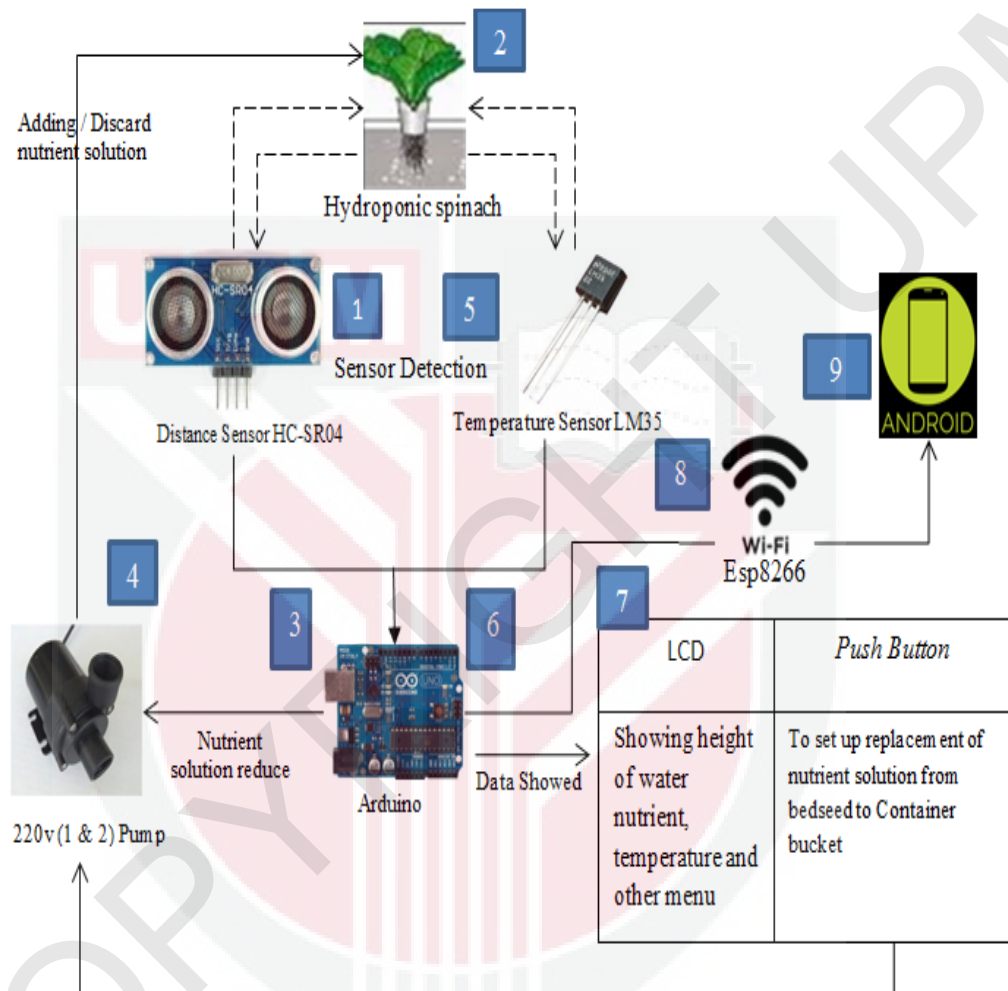

**Figure 2.4. Common Design of Computerized Hydroponics Sustenance Plants Frameworks (Eridani et al., 2018).**

Within the hydroponic framework, the fertilizer used is mixed into water, which is by then insinuated as hydroponics sustenance and nutrient arrangement. The enhancement or nutrient focus inside the solution, which is by then exhibited by the EC, is very significant in the solution. Nutrient fixation when in doubt mixed

physically by joining the fertilizer and the liquid in the accurate quantity (Eridani et al., 2018).

## **2.5 Nutrient Film Technique/Method**

These hydroponics framework needs exceptional consideration to a couple of considerations, for example, the liquid temperature, liquid level, concentration of the nutrient and acidity. Evidence were gathered from hydroponic NFT agriculturist after that, effectively evaluate and break down. Tragically, it is as yet constrained by using the normal method, for delineation in monitoring the convergences of nutrient must remain at the smallest every day, thus abundant time is misused. In watching out for these matters, we require a structure that can be used and associated adequately. The manufacturing of hydroponics was by watching and computerization scheme that can checked using devices related to microcontroller Arduino Uno, Raspberry Pi 2 and Wi-Fi module ESP8266 demonstrate microcomputers as the web server with the idea of IoT, there each square hydroponics developing can speak through webserver agent. Web used as the interface of the system that grants customer to monitor and control the NFT hydroponics developing. The NFT hydroponics web interface organization structures utilizing an approachable web structure, for example, JavaScript, Bootstrap for the front-end and JQuery collections. The outcome demonstrates that this framework encourages farmers to expand the effectivity and capability on watching and controlling Nutrient Film Technique hydroponics farming. Through this research, a sustenance reinforcing robotization framework of a model scaled hydroponics supplement or nutrient film method is arranged. The structure is arranged with a regulate focus by means of the R3 Arduino Uno panel. The framework is set up with GP2Y0A21 region device as a liquid mark discoverer, TDS device as a locator of EC of the nutrient arrangement, and motor servo opening contraption of the installation

inside the nutrient basin. The research resulted that the structure is able to carry out liquid transport thus when the liquid mark is not exactly the least dimension, and incorporate the nutrient automatically when the nutrient solution fixation is underneath 800 parts per million (PPM) (Eridani et al., 2018).

Supplement or nutrient film procedure is another methodology of hydroponics framework that utilize a flowed liquid holding nutrient as a creating medium of plants.

The basic consideration in NFT that impact the plant advancement are pH and EC that should be keep up in agreed run that rely upon plant sorts (Yolanda et al., 2017).

## 2.6 Summary of Literature Review

Along these lines, basic additions for the harvests in hydroponics framework are passed depending on the information sources gotten from the liquid mark device and the pH device used. The nutrient and liquid supply to the dissimilar diversities of crop is monitored and controlled at steady period breaks. (Umamaheswari et al., 2017). DWC might be a system that builds up the plant by giving the nutrient straight to the foundation of the plants until the plants can be reaped (Saaid et al., 2015). Their hydroponics frame work mandate explicit consideration in monitoring liquid mark, liquid temperature, acidity of nutrient solution, and greater thicknesses or densities of nutrient solution using devices are connected and related to the microcontroller through an online website (Crisnapati et al., 2017). Inquiry revealed that this system can observe the dimension of the EC or solute in nutrient solution ICITACEE 2017 174 using TDS device in parts per million unit (Eridani et al., 2018). In this consideration, they realized the soft reason to control the pH and EC state of the Nutrient Film Technique hydroponics framework in Web of Things framework condition (Yolanda et al., 2017).

## CHAPTER 3

### MATERIALS AND METHODS

#### 3.1 Site Location

Nutrient Film Technique (NFT) hydroponic framework was outlined and manufactured within the Workshop Technology Laboratory of the Department of Biological and Agricultural Engineering, Faculty of Engineering. Structured, assembled amidst the Department's soil and water conservation laboratory and machinery design laboratory, for 2 crops x 3 rows x 2 replica with its right pipe size, flowrate, angle of pipe degree and pump size in determining the most suitable fertilizer mixture ratio for lettuce and tomato and the need for suitable planting media for hydroponic system for holding the mixture of fertilizer content in the different media.

#### 3.2 Materials

All the materials listed below, were purchased at; cityfarm plt (d-3-39, pusat perdagangan bs, jalan bs 14/1, Taman Bukit Serdang , seksyen 14, 43300 Seri Kembangan, Selangor, Malaysia), lensen hardware trading (lot 447, jalan 18/2a, Taman Sri Serdang, 43300 Seri Kembangan, Selangor Darul Ehsan), d syira enterprise (456, jalan 18/2a, Taman Seri Serdang, 43300, Sri Kembangan) and mechway enterprise (230-g, jalan Serdang, 43300, Seri Kembangan). Table 3.1 shows the materials for the hydroponic NFT system.

**Table 3.1. Materials for the hydroponic NFT system.**

<ul style="list-style-type: none"><li>• UPVC pipe 3" 150cm</li><li>• Wood 1"x2"x10' cut into 4pcs 140cm/4pcs 40cm</li></ul>	<ul style="list-style-type: none"><li>• Liquid fertilizer AB</li><li>• Kintons KT:101 pump 5watt 1m 800L/H</li><li>• HP5 hydro cups 45mm</li></ul>
---	--

<ul style="list-style-type: none"> <li>• Wood 2"x2"x10' cut into 8pcs 60cm</li> <li>• Ceiling wood cut into 4pcs 100cm/4pcs 60cm/4pcs 140cm/4pcs 70cm</li> <li>• UPVC elbow 3"</li> <li>• PVC glue big pot</li> <li>• UPVC pipe 3" 20cm</li> <li>• UPVC end cap 3"</li> <li>• 80 liter plastic box with cover</li> <li>• Hole saw</li> <li>• pH meter</li> <li>• Screw (20pcs) 2"</li> <li>• Screw (30pcs) 1½"</li> </ul>	<ul style="list-style-type: none"> <li>• PL6 perlite</li> <li>• CF 500 coco fiber (s)</li> <li>• Clay pebbles</li> <li>• Hose ½" 3m</li> <li>• GW16 salada perancis</li> <li>• GW318 tomato cherry</li> <li>• PM02 peat moss 2kg</li> <li>• T104 tray semaian 104</li> <li>• Hose 1.3m</li> <li>• Ceiling wood 2m</li> <li>• Double sided 8m extension</li> </ul>
---	---

### 3.2.1 Bill of quantity (BOQ)

The bill of quantity refers to the number, quantity of items purchased for the fabrication and construction of the NFT system with per unit costs and total costings.

**Table 3.2. Bill of Quantity (BOQ).**

No.	Quantity	Items	Per unit cost (RM)	Total cost (RM)
1	6	UPVC pipe 3" 150cm	15.00	90.00
2	3	Wood 1"x2"x10' cut into 4pcs 140cm/4pcs 40cm	14.00	42.00
3	2	Wood 2"x2"x10' cut into 8pcs 60cm	28.00	56.00
4	6	Ceiling wood cut into 4pcs 100cm/4pcs 60cm/4pcs 140cm/4pcs 70cm	5.00	30.00

5	8	UPVC elbow 3"	8.00	64.00
6	1	PVC glue big pot	12.00	12.00
7	4	UPVC pipe 3" 20cm	2.00	8.00
8	4	UPVC end cap 3"	5.50	22.00
9	2	80 liter plastic box with cover	60.00	120.00
10	1	Hole saw	23.00	23.00
11	1	PH meter	70.00	70.00
12	1	Clay pebbles	13.50	13.50
13	2	Liquid fertilizer AB	29.00	58.00
14	2	Kintons KT:101 pump 5watt 1m 800L/H	25.00	50.00
15	6	HP5 hydro cups 45mm	5.00	30.00
16	1	PL6 perlite	8.00	8.00
17	1	CF 500 coco fiber (s)	5.00	5.00
18	3	Hose ½" 3m	3.00	9.00
19	1	GW16 salada perancis	2.80	2.80
20	1	GW318 tomato cherry	2.80	2.80
21	1	PM02 peat moss 2kg	7.00	7.00
22	1	T104 tray semaian 104	4.00	4.00
23	2	Hose 1.3m	3.20	6.40
24	4	Ceiling wood 2m	5.00	20.00
25	1	Double sided 8m extension	27.00	27.00
26	1pack	Screw (20pcs) 2"	2.00	2.00
27	1pack	Screw (30pcs) 1½"	2.00	2.00
28	10	Net 1m each	6.00	60.00
<b>Grand Total</b>				<b>= 844.50</b>

### 3.3 Method of pump sizing or selection for hydroponic system

In determining the finest pump for the system, there is need for this three categories to be put into consideration:

- 1 Estimate the GPH (gallons per hour) or LPH (litre per hour) for the pump flow.
- 2 Head height of the system should be measured.

Head height is the space or distance concerning the upper of the grow bed (or NFT tower) and the upper or topmost of the water tank. Calculation would not be needed for this. Determine the length in between the water line of sump and the exit point of irrigation.

- 3 Amalgamate or combine the gotten two values by means of the chart that accompanies the pump to determine the right size of pump required.

#### 3.3.1 Manning's equation for flowrate (Q) determination

Study on Manning's equation for determining the flowrate (Q) through the NFT hydroponic system are carried out using the following equations;

$$A = \pi r^2 \quad (3.1)$$

Where, A is the area (m<sup>2</sup>),  $\pi$  is dimensionless with value 3.142, r is the radius (m).

$$P = \frac{1}{2} \pi r^2 + d \quad (3.2)$$

Where, P is the perimeter (m), d is the diameter (m).

$$R = A/P \quad (3.3)$$

Where, R is the hydraulic radius (m).

$$V = \frac{k}{n} R_3^2 S_2^1 \quad (3.4)$$

Where, V is the velocity (m/s), K is a constant with value 1, n is the manning roughness with value 0.011 (Engineering ToolBox, 2004). S is the channel slope (m/m) with value 0.001. Therefore,

$$Q = AV \quad (3.5)$$

### 3.3.2 Pump size determination

Determination of suitable pump size for the system or power transmitted to the fluid by the pump in watt (P), with determined flowrate (Q) using the formula;

$$P = Q\rho H9.81 \quad (3.6)$$

Where, P is the pump power (watt), Q is the flowrate ( $m^3/s$ ),  $\rho$  is the density of the liquid ( $kg/m^3$ ), H is the piezometric height of water (m), 9.81 is the average intensity of gravity.

### 3.4 Methods for the NFT System

Method of the setup of the experimental system of the hydroponics NFT structure arrangement process is as follows:





1. Review guide and all site layout diagrams and prepare the site.
2. Structure the wood stand that the pipes or gutter will sit on. Create one that fits the space available. Set up as a table system with net awnings.
3. Using the UPVC pipe 3" (150cm) NFT channel, drill holes with distances of 15cm, with the aid of the milling machine mounted with hole saw to get the required size for placement of the HP5 hydro cups 45mm diameter, and glue the UPVC with UPVC elbows together using PVC glue to prevent leakages.
4. Place pots into the NFT channel, but do not fill with growing media just yet.
5. Germinate the lettuce and cherry tomato seedlings using the tray filled with peat moss with constant watering with moderate nutrients as specified on the nutrient bottles A&B, for two weeks minimum, before transferring them to the NFT media.







6. Prepare storage container with nutrient solutions and set it below the NFT structure. Nutrient solution mixture in the guppy tank container will be pumped through continuous re-circulation. Read directions carefully on the hydroponic A&B liquid fertilizer to know the exact amount required to pour into the 80 litre guppy tank nutrient container for exact amounts. Stir it gently and give the nutrient time to mix with the water. Measure the pH and EC, and adjust accordingly.





Note: The required pH and EC values will vary depending on the requirements of the plants.

7. Put a submersible water pump into the container. Attach hose line.
8. Auger a littler opening into the highest point of the NFT complex channel pipe to grapple the pipe from the siphon.
9. Attach a pipe to the highest point of the manifold to circle the supplement arrangement. The tallness and situation of the NFT channel pipe should be acclimated to guarantee that the siphon can convey the supplement arrangement constantly and viably.
10. Test system and check for leakages and proper flow to each NFT channel manifold.
11. Add growing medium to the net cups or plant pots into the NFT channel.
12. Have a net awning over the system to protect it from contaminants, insects and pests, sunlight and also to serve as support for the system.
13. Weekly or daily maintenance will be required including upscaling or downscaling water and nutrients, pH and EC monitoring and controlling, flushing out accumulated nutrients, etc.

**Table 3.3. Methods of NFT fabrication and complete setup processes.**

	
<p>a) Sized and gathered all material PVCs and woods needed in workshop technology lab.</p>	<p>b) Drilled 45mm diameter holes for placement of net pots, using the milling machine.</p>
	
<p>c) Assembled the PVCs and cut the base wood stand support, using the vertical saw machine and assembled them together using nails and hammer.</p>	<p>d) Finished and assembled PVCs and base wood stand support.</p>

	
<p>e) Assembling ceiling wood for net protection/awning.</p>	<p>f) The completed ceiling wood assembly with net protection/awning.</p>
	
<p>g) Positioned the peat moss into the tray holes.</p>	<p>h) Day 1: Seeding the lettuce and tomato into prepared tray set with peat moss.</p>
	
<p>i) Day 4: The lettuce seeds and tomato seeds started germinating.</p>	<p>j) Day 6: The germinating seeds started emerging.</p>

	
<p>k) Day 14: Ready for transplant.</p>	<p>l) Prepared the right ratios using liquid fertilizer A&amp;B for lettuce and tomato.</p>
	 
<p>m) Mixed thoroughly the right ratios of fertilizer A&amp;B with clean water inside the guppy tank.</p>	<p>n) Checked the right pH using the pH meter and the right EC using the EC meter.</p>

	
<p>o) Placed and started the pump inside the guppy tank with the prepared nutrient for 24/7 circulation through the UPVC manifolds.</p>	<p>p) Placed the lettuce seedlings inside the net pots with the right amount of perlites for support.</p>
	
<p>q) Placed the lettuce seedlings inside the net pots with the right amount of clay pebbles for support.</p>	<p>r) Placed the lettuce seedlings inside the net pots with the right amount of coco fiber for support.</p>



s) Placed the tomato seedlings inside the net pots with the right amount of perlites for support.



t) Placed the tomato seedlings inside the net pots with the right amount of clay pebbles for support.



u) Placed the tomato seedlings inside the net pots with the right amount of coco fiber for support.

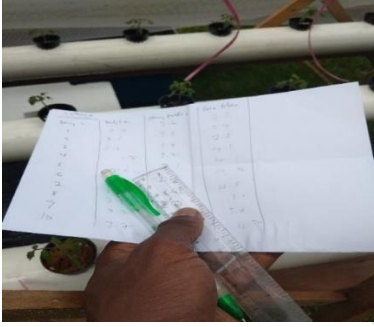

v) Placed all the prepared net pots into the respective manifolds drilled holes and attach the pump linings.

	
<p>w) Closed the net protection/awning properly/tightly to prevent the seedling plants from direct sunlight and insect attacks.</p>	<p>x) Readings taken on a weekly basis as well as continuously monitor nutrient content in the guppy tank and adjust the pH and EC accordingly to keep the right pH and EC proportions.</p>

### 3.5 Suitable Fertilizer Mixture Rate for Lettuce and Tomato

Determining the suitable mixture rate for lettuce and tomato, dissimilar pH and EC ranges are involved for the two dissimilar vegetables.

#### 3.5.1 Urban grower's desired leafy greens fertilizer A&B

This compost has a definitive equalization of developing supplements required for a sound, energetic verdant yield. This extraordinarily detailed hydroponic compost is customized to develop verdant/leafy greeneries.

- Boosted calcium, magnesium, and sulphur for healthier plants.
- Contains chelated molybdenum, manganese, zinc, boron, copper, and iron as trace elements.
- This product does NOT enclose any ingredient designated by OSHA, IARC, and ACGIH as probable or suspected human carcinogens.

### 3.5.2 Seedlings mixing guideline

Regarding the seedling mixture guidelines below two weeks old the following steps below has to be followed;

1. Solutions A&B are 100 times concentrated. Henceforth, nutrient A and nutrient B with dilution ratio of 1:200 mixed with fresh water before feeding plants below 14 days old.
2. Dilute 5 ml both solutions A&B with 1 litre of clean or fresh liquid.
3. Blend the nutrient solution thoroughly and feed to plants.

### 3.5.3 Maturing plants mixing guideline

Regarding the seedling mixture guidelines above two weeks old the following steps below has to be followed:

1. A&B nutrient solutions are multiple times concentrated (100 times). Subsequently, supplement A and supplement B with weakening proportion of 1:100 blended with clear water before sustaining plants over 14 days old as shown in Figure 3.1.
2. Dilute 10 ml both solutions A&B with 1 litre of spotless or new water. For example to compose 10 litre of supplement sustaining arrangement, include 100 ml both solutions A&B into 10 litre of spotless or new liquid/water.
3. Blend the nutrient solution thoroughly and feed to plants.

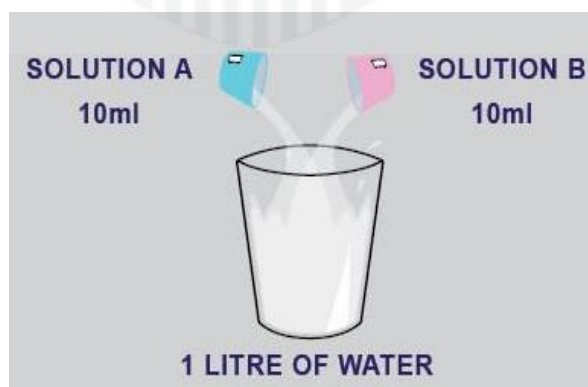

**Figure 3.1. Maturing Plants Mixing Guidance.**

### 3.6 Maintenance and Adding Instructions

The considerations on the maintenance and feeding instructions of the NFT structure setup, the following steps should be abided by as follows:

- Replace tank nutrient solution with fresh solution as a minimum once every two weeks (weekly if at all possible). Old nutrient solution should be dumping on some plants outside if necessary.
- Retain a pH of 5.5 - 6.0 for cherry tomato and EC around 2.0 - 5.0, and pH of 6.0 - 6.5 for lettuce and an EC around 0.8 - 2.0 (Saaid et al., 2015).
- Keep an eye on the plants in monitoring pests and diseases. Making sure lid is always secure over the guppy tank to minimize debris content in the nutrient solution.
- Always make sure the system is kept clean with fresh nutrient solutions for abundant yields.

Extensions: Monitor EC and pH in the media and measure plant height growth weekly.

Assessment: After creating the system review and summarize the following concepts :

- Foods can be grown without soil.
- The system must have nutrients to grow healthy plants.
- It is essential to monitor the system to keep the plants healthy and growing properly.

### **3.7 Statistical Analysis**

The judgement on the best selection of fertilizer mixing ratio is subjected to statistical analysis for example ANOVA, Mean comparison and SPSS was used to determine the significance of the mean value for plant height, leaf number, plant weight and so on, and the adjustment based on Post Hoc; DMRT Multiple Comparison Duncan test.

## CHAPTER 4

### RESULTS AND DISCUSSIONS

#### 4.1 Design of NFT Systems

Design of NFT system for growing tomato and lettuce which include pipe size, angle of pipe degree, flowrate, and pump size.

##### 4.1.1 Schematic design for butterhead lettuce NFT system

Through the NFT design process using Autodesk AutoCAD 2017 for butterhead lettuce structure as shown in Figure 4.1, the 3" (0.7 m) UPVC pipe diameter was put into consideration and constructed with a length of 1.5 m each for 3 media, these pipes were connected using a 90 degree elbow joint with a net pot spacing of 0.15 m through the manifolds, and 80 litre guppy tank for the storage of the nutrient and water that needs to be supplied through the pipes simultaneously to the plants by a submersible pump. Wooden structure was fabricated to serve as base support for this NFT system with head height of 0.6 m from the ground and distance of 1.4 m supporting the pipes weight with liquid nutrients. Furthermore, a net protection was constructed through wooden support for the system with height of 0.63 m to prevent direct sunlight penetration and insect attacks to the butterhead lettuce plants. Figure 4.1 shows the NFT system design for butterhead lettuce.

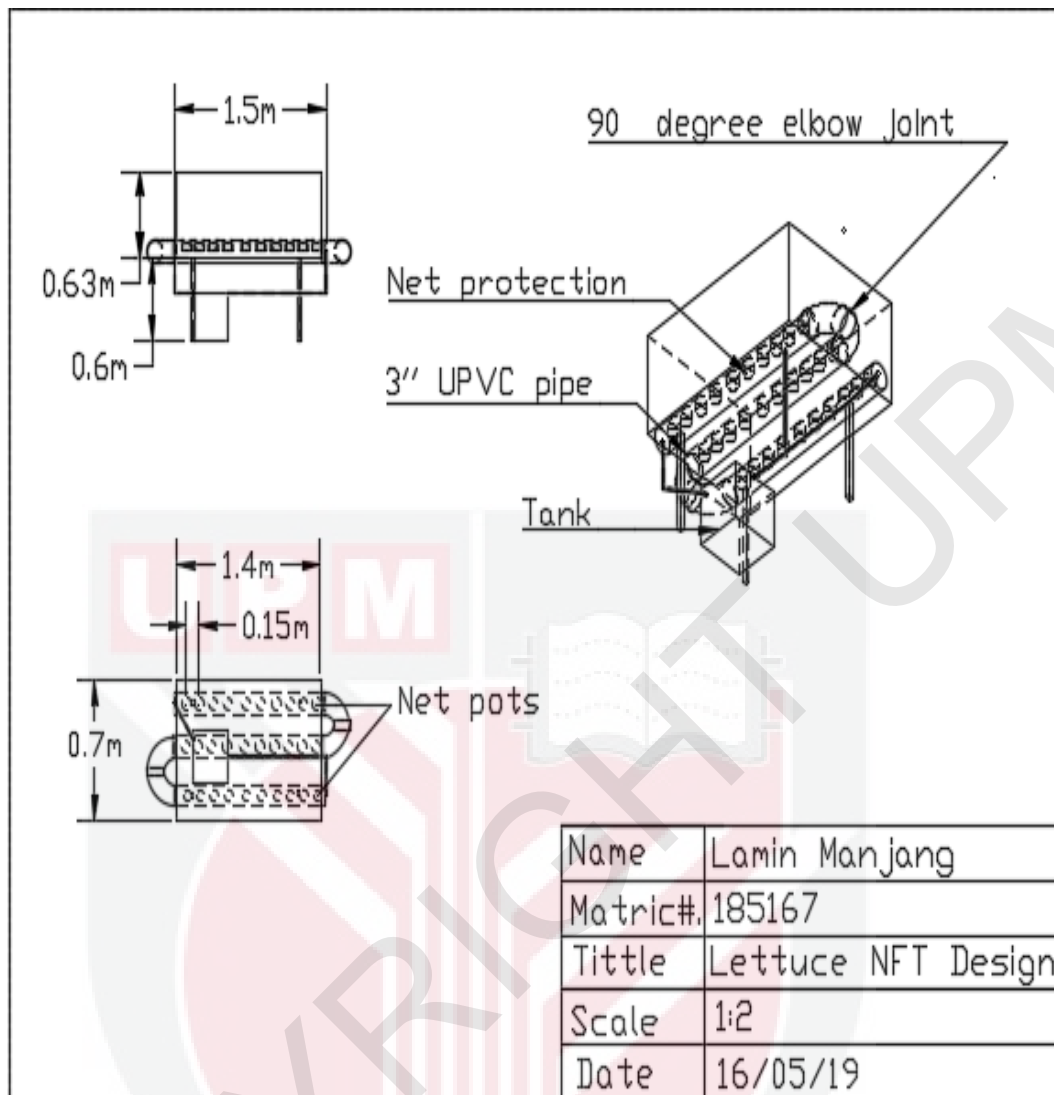
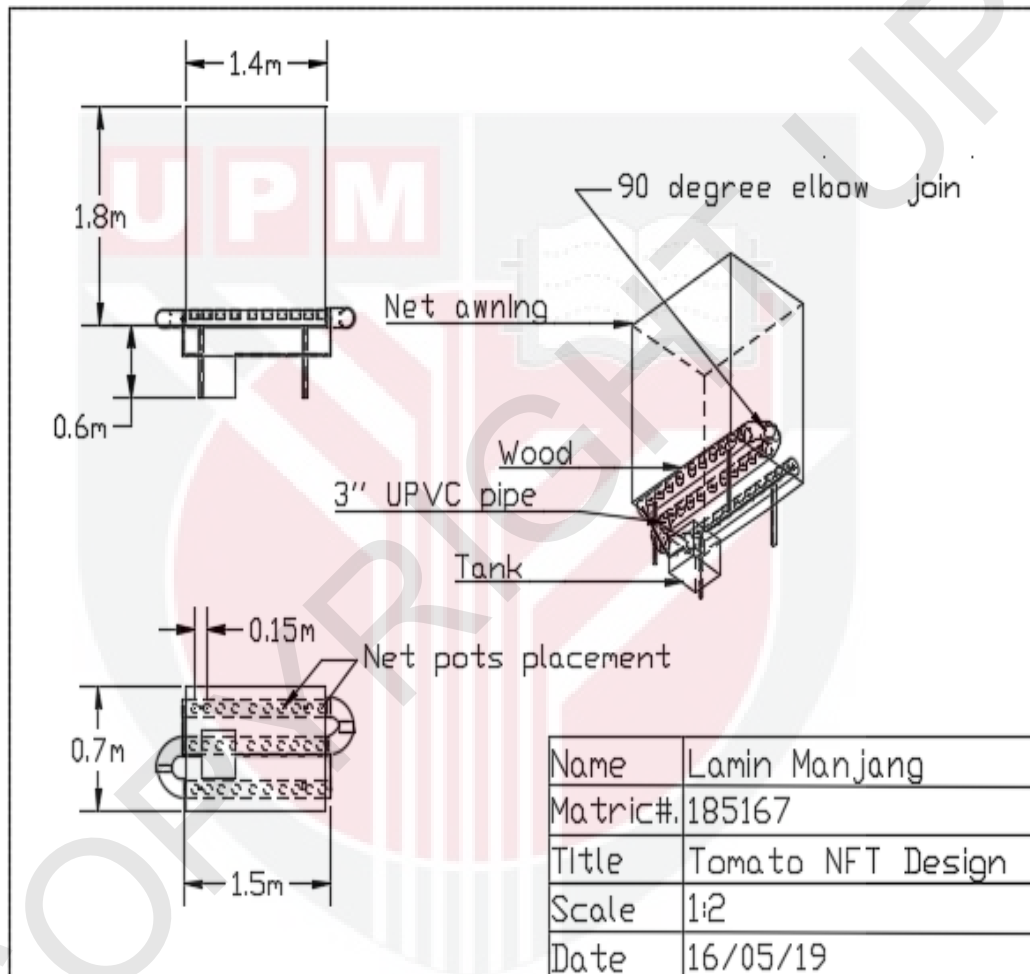

**Figure 4.1. NFT System Design for Butterhead Lettuce.**

#### **4.1.2 Schematic design for cherry tomato NFT system**

During the NFT design preparation using Autodesk AutoCAD 2017 for cherry tomato structure as appeared in Figure 4.2, the 3" (0.7 m) UPVC pipe diameter was put into thought and developed with a length of 1.5 m each for 3 media, these channels were associated utilizing a 90 degree elbow connection with net pot placement spacing of 0.15 m through the manifolds, and 80 litre guppy tank for the capacity of the supplement and water that must be provided through the channels at the same time to the plants by a submersible pump. Wooden structure was created to serve as base

bolster for this NFT framework with head height of 0.6 m from the ground and distance of 1.4 m supporting the channels weight with fluid supplements. Moreover, a net assurance was developed through wooden bolster for the framework with height of 1.8 m to avoid coordinate daylight infiltration and creepy crawly assaults or insect attack on the cherry tomato plants Figure 4.2 shows the NFT system design for cherry tomato.



**Figure 4.2. NFT System Design for Cherry Tomato.**

#### 4.1.3 Finding the flowrate (Q)

In finding the flowrate, the Manning's equation was put into consideration and used in determining the flowrate through the 3" UPVC pipe for the NFT hydroponic system. Getting the determined flowrate through the UPVC pipe required for the NFT system for the lettuce and tomato, with the obtained parameters such as, Area,  $A = 4.560e-$

3 m<sup>2</sup>, the Perimeter, P = 0.0785 m, Hydraulic radius, R = 0.0581 m, Velocity, V = 0.431 m/min, and thus, amounted to the Flowrate, Q = 117.9 L/hr for the hydroponic system. Refer to (Appendix I) for details.

The recommended flowrate is usually in a range of 1 - 2 litre every minute for each develop pipe canal or extending from 60 - 120 litre for each hour (CITYFARM PLT, 2019).

#### **4.1.4 Determination of pump size/power (P).**

Throughout the determination for the suitable pump size for the system or power transmitted to the fluid by the pump in watt (W), with determined flowrate (Q) = 3.275e-5 m<sup>3</sup>/s from the previous result in 4.1.3, given density of the liquid (p) = 1000 kg/m<sup>3</sup>, determined piezometric height of water (H) = 0.6 m from Figure 4.1, and putting into consideration the average intensity of gravity which = 9.81, thus, the determined pump size for the system, P = 0.193 watt. Therefore, in choosing the right pump size, Kintons 101 pump of 5 watt was suitable for this NFT system (CITYFARM PLT, 2019).

#### **4.2 Most Suitable Fertilizer Mixture Rate for Lettuce and Tomato**

Determining the most suitable fertilizer mixture rate for lettuce and tomato, different pH and EC ranges are involved for the two different vegetables.

The butterhead lettuce fertilizer nutrient A&B weekly addition, as demonstrated in Figure 4.3 predicted an average optimum weekly addition of about 600 ml meaning roughly 86 ml daily addition of fertilizer Nutrient A&B.

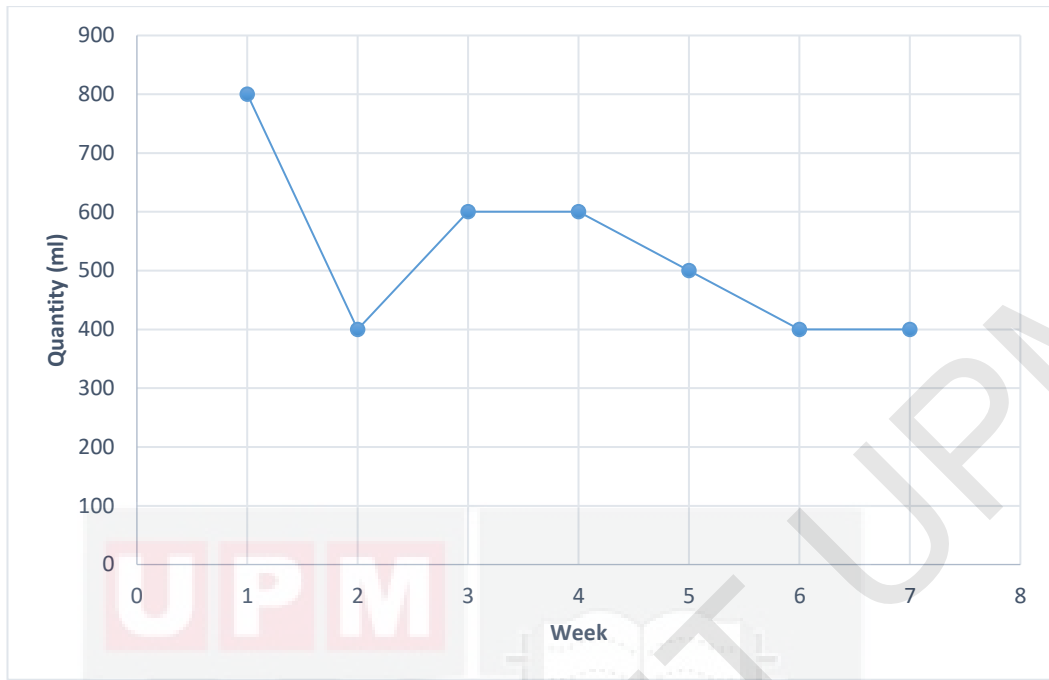

**Figure 4.3. Butterhead Lettuce Nutrient A&B Amount Used.**

The cherry tomato fertilizer supplement A&B week by week addition, as illustrated in Figure 4.4 anticipated a normal ideal week by week expansion of an optimum value of about 2100 ml meaning 300 ml addition on a daily basis of fertilizer nutrient A&B.

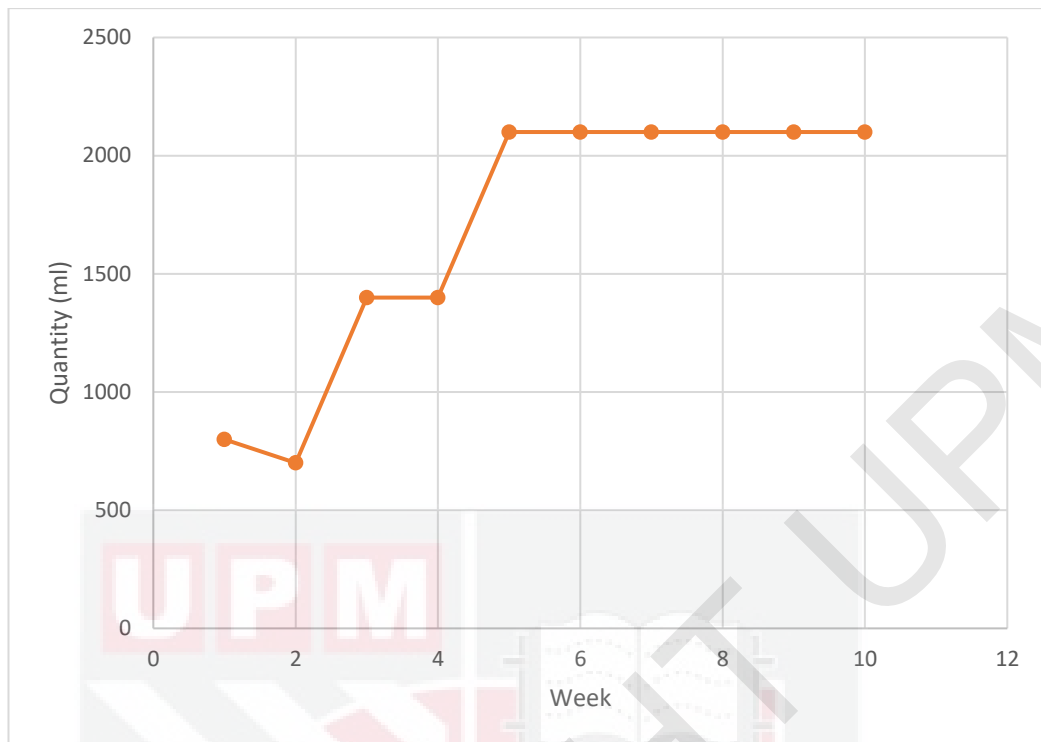

**Figure 4.4. Cherry Tomato Nutrient A&B Amount Used.**

Notwithstanding, the way that the over debilitating rate can be used as a rule of thumb, it is consistently better than the use of an electrical conductivity meter. Modify the EC level to 1.0 - 1.5 mS/m or 1000 - 1500  $\mu$ S/m for leafy plants. Incorporate greater enhancement to broaden EC or incorporate more water to reduce EC. Consenting to this investigation, by including 1 ml of nutrient solution in the socializing container with the capacity of liquid 10 litre could increase  $\text{pH} \pm 0.01$  and by including 1 ml of nutrient solution in the same 10 litre capacity tank could lessen  $\text{pH} \pm 0.015$ . Though for EC, by including 1 ml of nutrient solution A and 1 ml of nutrient solution in the socializing container with the capacity of liquid 10 litre could increase  $\text{EC} \pm 0.034$  (Yolanda et al., 2017).

The required EC and pH parameters vary in a wide range. It ought to be put into thought that particular plant necessities will change agreeing to territorial climatic conditions and from season to season according to different localities. EC can be

communicated as either milliSiemens per meter (mS/m), or parts per million (PPM) in which, 1 mS/m = 700 ppm. As a thumb rule or generally accepted rule, in cooler months, plants will have the most supplement necessity, and in most humid months lower supplement prerequisite. Hence, amid winter more grounded supplement arrangement ought to be held, whereas amid summer weaker arrangement is required.

#### 4.2.1 The suitable fertilizer mixture rate for butterhead lettuce

This pH level will differ according to different plant requirement, although in a broad-spectrum many plants desire a slightly acid growing environment, for lettuce it prefer a pH range of 5.5 - 6.5, though most plants can still endure in an environment with a pH of between 5.0 - 7.5. Demonstrated in Figure 4.5 predicted an optimum pH of about 6.2.

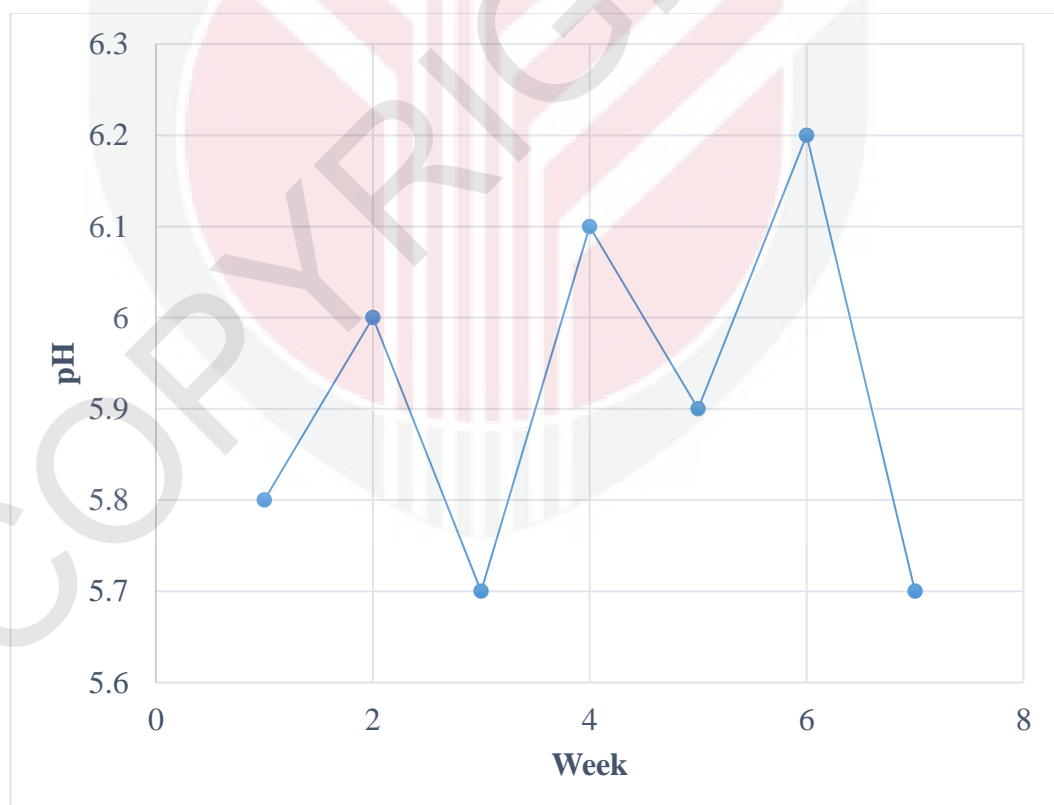

**Figure 4.5. Butterhead Lettuce pH Meter Readings.**

The water pH rate strategy to the significant liquid culture should be kept up to ensure that the plants grow adroitly. Agreeing to this study, plant test was carried on green

mustard. The required pH rate range for green mustard is around 6.0 to 7.5 (Saaid et al., 2015).

This EC level will contrast concurring to distinctive plant prerequisite, in spite of the fact that in broad-spectrum numerous plants crave a marginally corrosive developing environment, for lettuce it favor EC range from 0.8 - 2.0 mS/m, in spite of the fact that most plants can still persevere in an environment with EC of between 0.8 - 1.2 mS/m.

Shown in Figure 4.6 predicted an optimum EC value of about 1.2 mS/m.

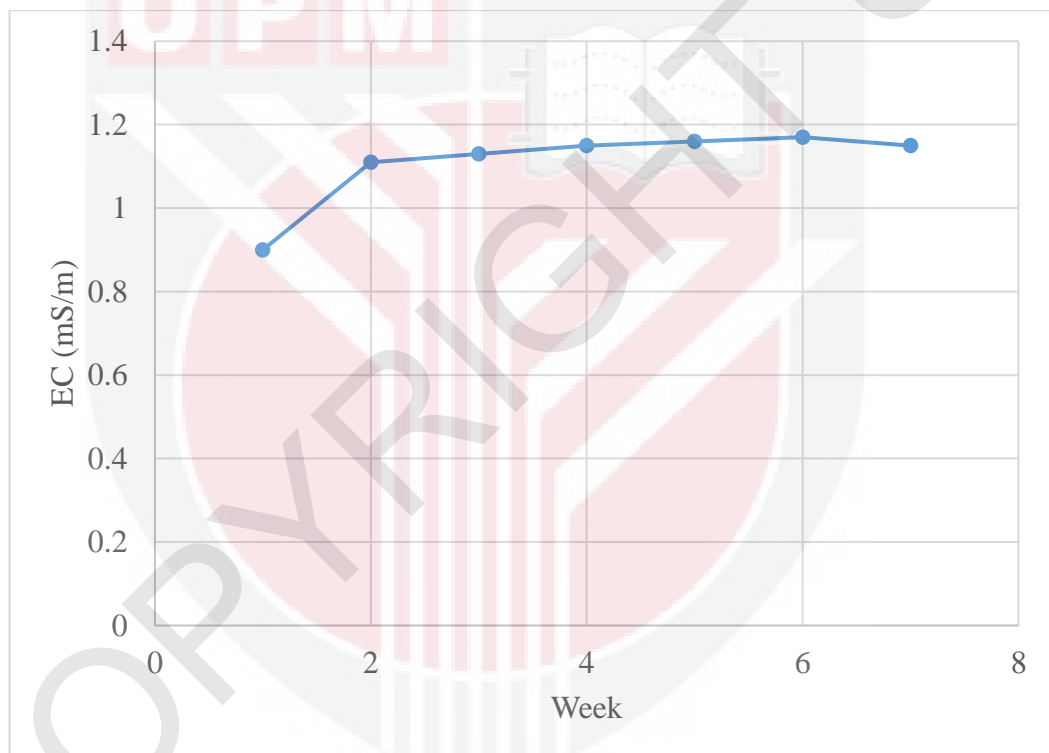

**Figure 4.6. Butterhead Lettuce EC Meter Reading.**

#### **4.2.2 The suitable fertilizer mixture rate for cherry tomato**

The foremost commonly pH utilized logical strategy for positioning sharpness, and it goes from 0 - 14, with low numbers being the foremost acidic and tall numbers being the slightest acidic. The suggested pH for vegetables such tomatoes ranges from 5.5 - 6.5 as shown in Figure 4.7 predicting the optimum pH value at 6.3.

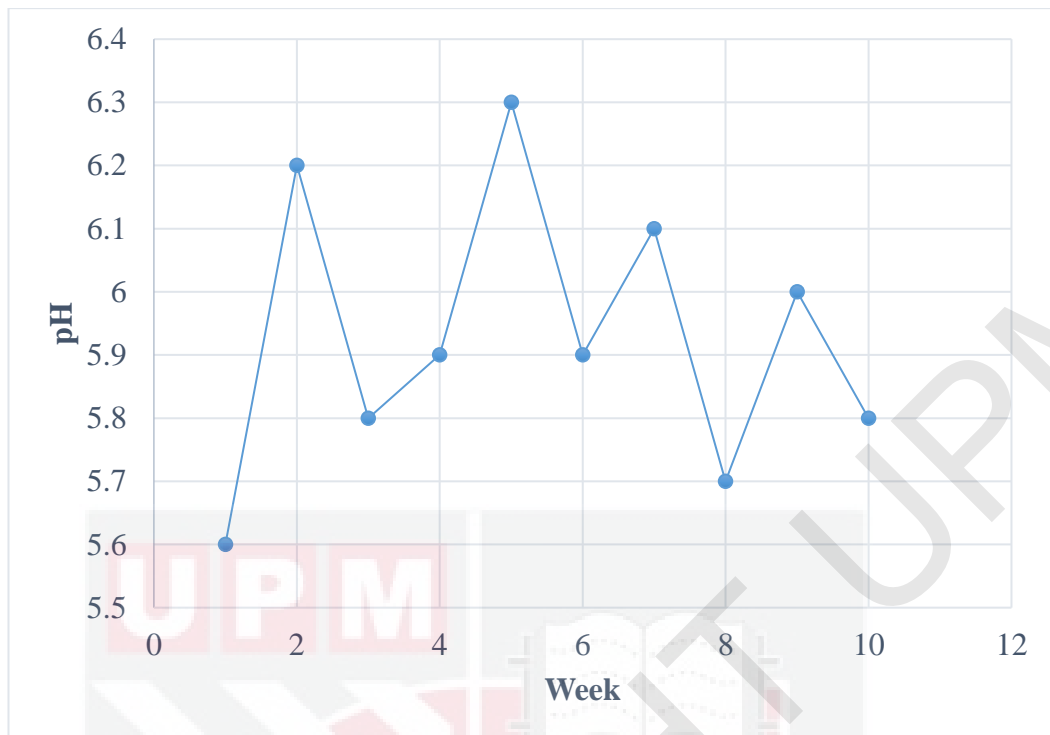

**Figure 4.7. Cherry Tomato pH Meter Readings.**

For a perfect building up, the fertilizer nutrient content for tomato cherry plants should range in pH stretch of 5.5 - 6 with an EC of 2.0 - 5.0 mS/m. The device picked to screen pH of hydroponics plan depends on molecule specific cathodes. Structure of EC and pH, was introduced in a PVC pipe (6 x 8 x 20 mm). The ideal EC for tomato cherry arrangement plan is inside the scope of 1.8 to 3 mS/m (Velazquez et al., 2013).

For a culminate building up, the upgrade course of activity for tomato cherry plants ought to run an EC of 2.0 - 5.0 mS/m as demonstrated in Figure 4.8, predicted an optimum EC value of about 4.3 mS/m.

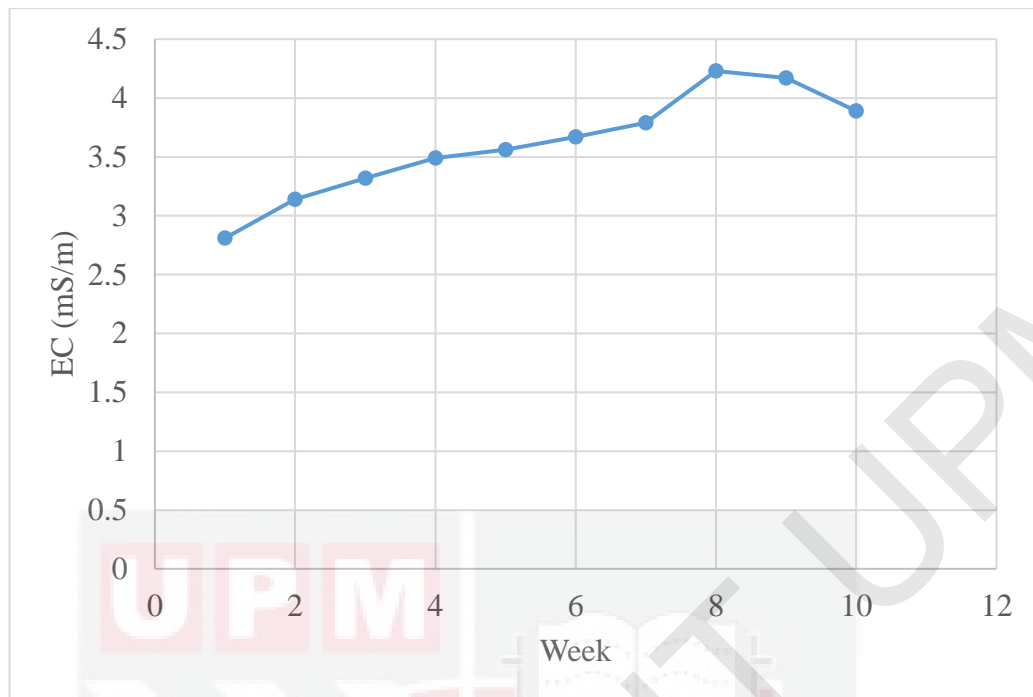

**Figure 4.8. Cherry Tomato EC Meter Readings.**

#### **4.2.3 Maturing variations for butterhead lettuce plants**

Weekly pictures were taken for the growth variations for butterhead lettuce. Table 4.1 shows the weekly variations for butterhead lettuce maturing plants.

**Table 4.1. Weekly variations for butterhead lettuce maturing plants.**

Placed in NFT Week 1	Week 2



#### 4.2.4 Maturing variations for cherry tomato plants

Week after week pictures were taken for the development varieties for cherry tomato.

Table 4.2 demonstrated the weekly variations for cherry tomato plants.

**Table 4.2. Weekly variations for cherry tomato plants.**

	
<p>Placed in NFT Week 1</p>	<p>Week 2</p>
	
<p>Week 3</p>	<p>Week 4</p>
	
<p>Week 5 (flowering begins)</p>	<p>Week 6</p>



Week 7 (fruiting begins)

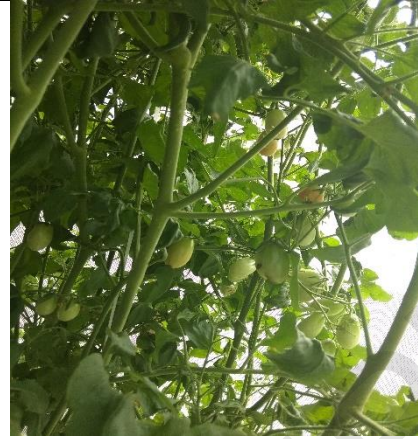

Week 8



Week 9 (ripe fruits)

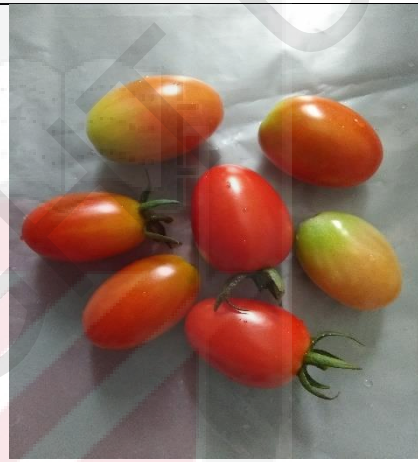

Week 10 (1<sup>st</sup> produce)



Week 11 (2<sup>nd</sup> produce)



Week 12 (3<sup>rd</sup> produce)



Week 13 (4<sup>th</sup> produce)

#### **4.3 The Need of Suitable Planting Media for the NFT Hydroponic System**

The judgment on the leading choice of fertilizer blending proportion is subjected to factual investigation for illustration ANOVA, Mean comparison and SPSS was utilized to decide the centrality of the mean esteem for plant height, leaf number, and so on, and the alteration based on Post Hoc Numerous DMRT Multiple Comparison using Duncan test. Also the Chlorophyll content was determined using SPAD-502 meter both in butterhead lettuce and cherry tomato leaves, weight variations was also determined through the harvested butterhead lettuce, cherry tomato fruits and plants weight using Microsoft Excel.

##### **4.3.1 ANOVA, Mean comparison and SPSS analyzed butterhead lettuce data**

Through the One-way ANOVA, Mean comparison and SPSS plant height variations in the three different media (perlite, clay pebbles and coco fiber) and the alteration based on Post Hoc Numerous Comparison using Duncan test run at significance level of 0.05. 9 Harmonic Mean Sample Size was used for each media totaling 27 sample size for the 3 media. From Table 4.3 demonstrate between groups and within groups showed a significance difference with a sig. of 0.004 meaning that ( $p < 0.05$ ). Post Hoc

Tests Homogeneous Subsets height comparison using Duncan in Table 4.4 indicates that perlite media varies significantly from the clay pebble and coco fiber media which showed no significance between them.

**Table 4.3. Showing the significance value between groups and within groups through height comparison using one-way ANOVA for butter head lettuce.**

**ANOVA**

Height

	Sum of Squares	df	Mean Square	F	Sig.
Between Groups	1505.407	2	752.704	6.901	.004
Within Groups	2617.667	24	109.069		
Total	4123.074	26			

**Table 4.4. Demonstrated that perlite media was significant from clay pebble and coco fiber media which showed no significance difference for butterhead lettuce.**

**Height**

Duncan<sup>a</sup>

Media	N	Subset for alpha = 0.05	
		1	2
1.00	9	14.0556	
2.00	9		27.2778
3.00	9		31.6111
Sig.		1.000	.387

Means for groups in homogeneous subsets are displayed.

a. Uses Harmonic Mean Sample Size = 9.000.

**NB:** 1=Perlite Media, 2=Clay Pebbles Media, 3=Coco Fiber Media

### 4.3.2 ANOVA, Mean comparison and SPSS analyzed cherry tomato data

Through the One-way ANOVA, Mean comparison and SPSS plant height variations within the three distinctive media (perlite, clay pebbles and coco fiber) and the change based on Post Hoc Numerous DMRT Multiple Comparison utilizing Duncan test run at importance level of 0.05. 9 Consonant Mean Test Estimate was utilized for each media totaling 27 sample for the 3 media. From Table 4.5 illustrate between groups and within groups are not significant which denote a sig. of 0.472 meaning that ( $p > 0.05$ ). Post Hoc Tests Homogeneous Subsets height comparison utilizing Duncan test in Table 4.6 shows that perlite, clay pebble and coco fiber media which appeared no significance or centrality between them.

**Table 4.5. Appearing no significance difference between groups and within groups through height comparison utilizing one-way ANOVA for cherry tomato.**

ANOVA					
Height	Sum of Squares	df	Mean Square	F	Sig.
Between Groups	99.852	2	49.926	.774	.472
Within Groups	1548.444	24	64.519		
Total	1648.296	26			

**Table 4.6. Illustrated that perlite, clay pebble and coco fiber media which appeared no significance difference falls in the same group for cherry tomato.**

**Height**

Duncan<sup>a</sup>

Media	N	Subset for alpha = 0.05
		1
1.00	9	212.2222
3.00	9	214.0000
2.00	9	216.8889
Sig.		.256

Means for groups in homogeneous subsets are displayed.

a. Uses Harmonic Mean Sample Size = 9.000.

**NB:** 1=Perlite Media, 2=Clay Pebbles Media, 3=Coco Fiber Media

**4.3.3 Harvested butterhead lettuce weight variations**

The 27 net pot samples from the hydroponic butterhead lettuce, 9 butterhead lettuce were harvested each from clay pebbles and coco fiber media, while only 5 butterhead lettuce were harvested from the perlite media and the remaining 4 butterhead lettuce seedlings could not catch-up with the growth in the perlite media. The maximum harvested butterhead lettuce weight recorded was 267.5g from the clay pebble media. As a result clay pebble media recorded the highest weight of the harvested lettuce followed by coco fiber media and the least weight was recorded by the perlite media as shown in Figure 4.9.

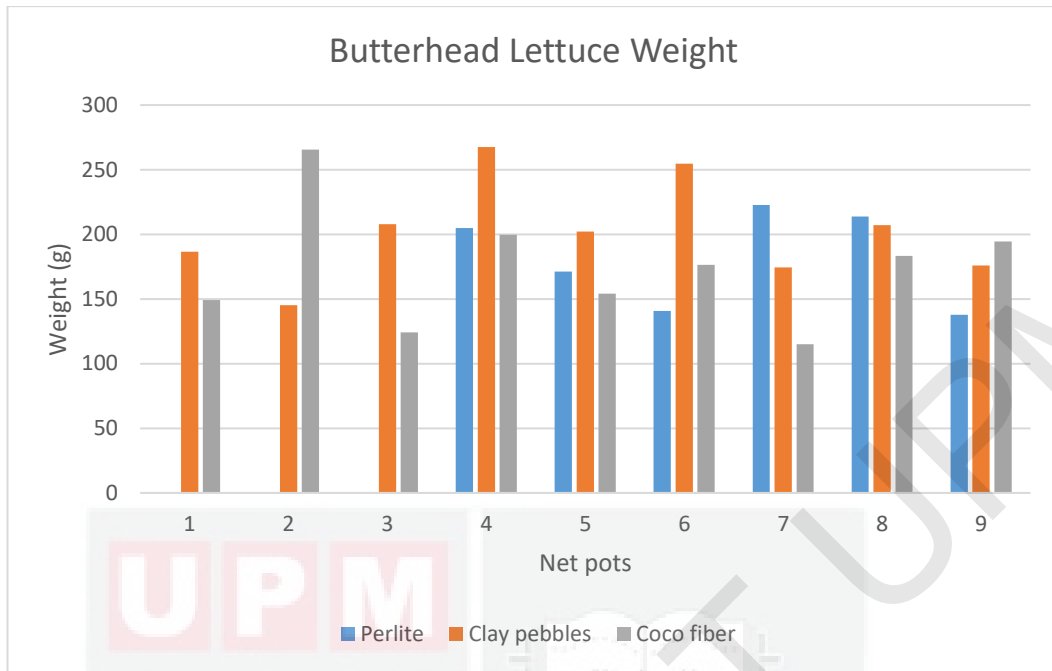

**Figure 4.9. Weight variations in harvested butterhead lettuce.**

#### **4.3.4 Harvested cherry tomato fruits weight variations**

According to the Figure 4.10 the weight variations between the three media (coco fiber, clay pebbles and perlite) was demonstrated through the harvested cherry tomato fruits from the 27 samples, 9 samples from each media. From the weight analysis, clay pebble recorded the highest fruit weight of 12.4g and it also yielded more fruits and also recorded greater weights, followed by perlite media and the least was recorded by the coco fiber media.

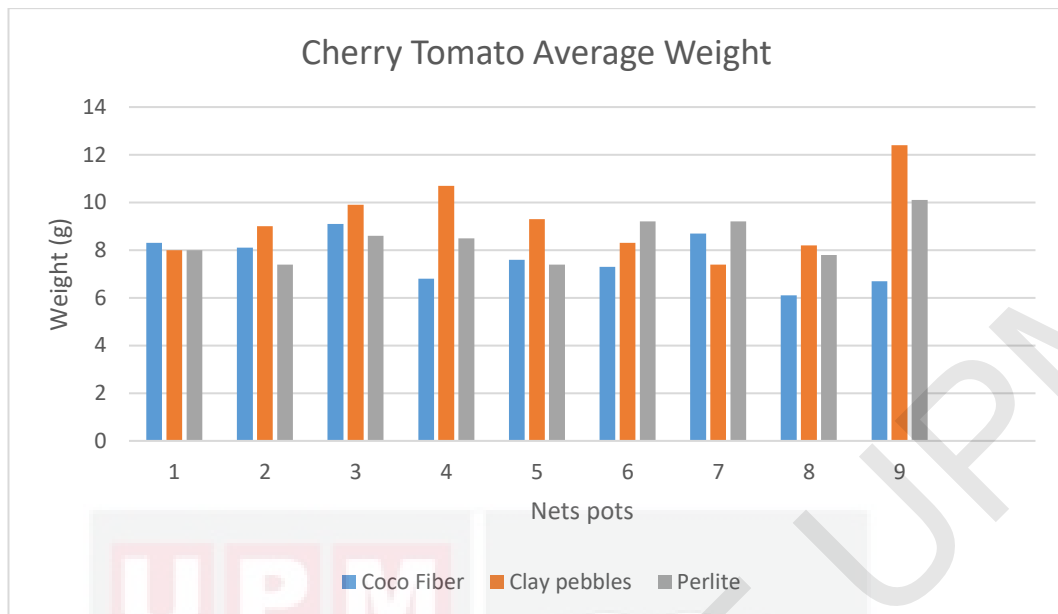

**Figure 4.10. Average Weight Variations in Harvested Cherry Tomato Fruits.**

#### 4.3.5 Cherry tomato stem fruits weight sustenance capacity

The highest weight recorded for cherry tomato stems to withstand its fruits weight was 173.6g in net pot 9 of clay pebble media and the lowest weight was 36.5g in net pot 6 of coco fiber media. Figure 4.11 shows the stem cherry tomato fruits weight sustenance variations.

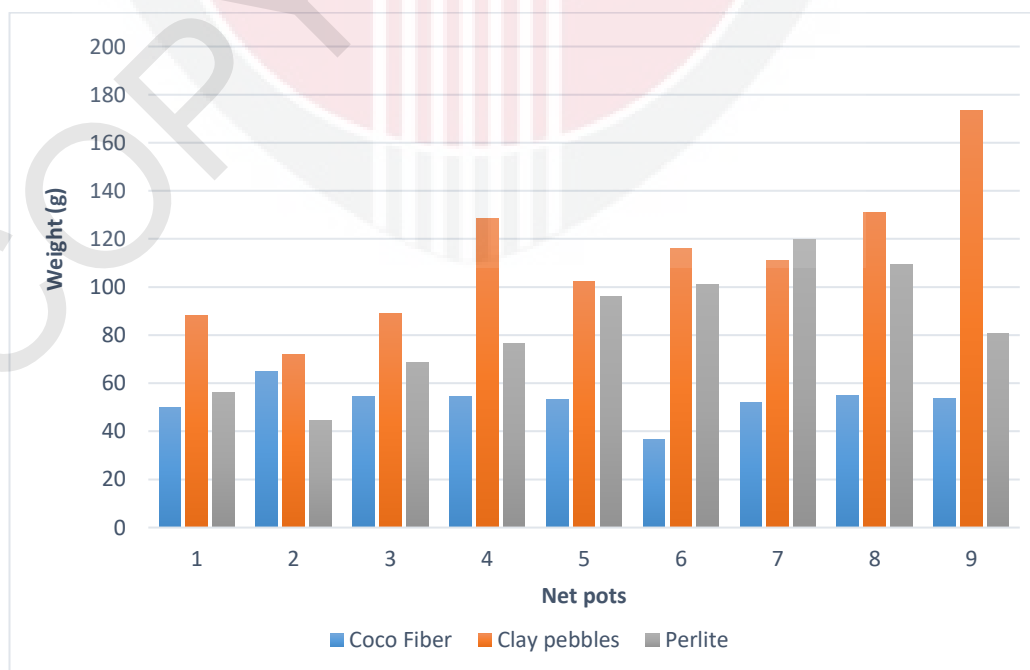
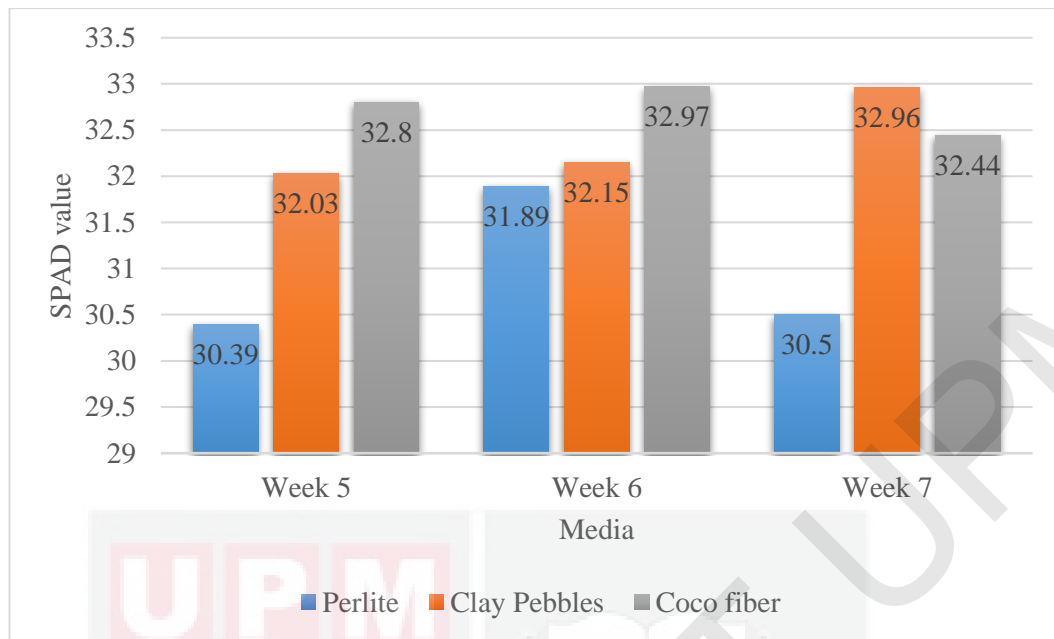

**Figure 4.11. Stem cherry tomato fruits weight sustenance.**

#### 4.3.6 Chlorophyll content in matured butterhead lettuce leaves

The collected 27 samples and reading leave numbers 3 for each lettuce plant from week 5, week 6 and week 7 from the three media (perlite, clay pebbles and coco fiber) as demonstrated in Figure 4.12. SPAD-502 meter was used in collecting the samples and the average SPAD-502 values were computed. In week 5, maximum of 32.8 from coco fiber media and minimum of 30.39 from perlite media was recorded, while in week 6, recorded highest of 32.97 from coco fiber media and lowest of 31.89 from perlite media and in the final week 7 before harvesting clay pebble media recorded the highest SPAD-502 value of 32.96 followed by coco fiber media and the least perlite media.

According to their study, the normal of SPAD-502 values ranges from the least  $2.7 \pm 0.8$  of head cabbage (Kbs) up to the most elevated  $52.4 \pm 3.7$  of Chinese cabbage pak-choi (Pch). The SPAD-502 esteem is corresponding to the relative sum of chlorophyll substance and reliable with their color appearance, in which the head cabbage has light green leaves, while Chinese cabbage pak-choi has darker green foliage. Higher SPAD-502 esteem implies higher chlorophyll substance (Limantara et al., 2015).

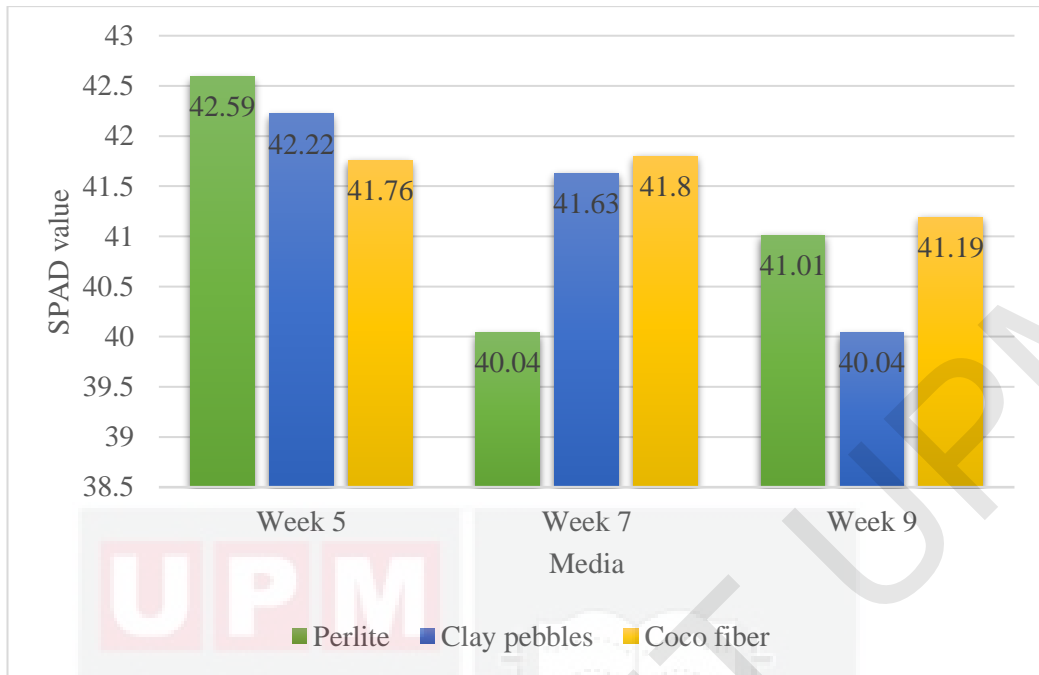

**Figure 4.12. Chlorophyll content in matured butterhead lettuce leaves.**

#### **4.3.7 Chlorophyll content in matured cherry tomato leaves**

The collected 27 test perusing leaf numbers 7 at the 10<sup>th</sup> branch each from week 5, week 6 and week 7 from the three media (perlite, clay stones and coco fiber) as illustrated in Figure 4.13. SPAD-502 meter was utilized in collecting the tests and the normal SPAD-502 value was computed. In week 5, greatest of 42.59 from perlite media and least of 41.76 from coco fiber media was recorded, whereas in week 7, recorded most noteworthy of 41.8 from coco fiber media and most reduced of 40.04 from perlite media and within the fruiting week 9, coco fiber media recorded the most elevated SPAD-502 value of 41.19 taken after by perlite media and the slightest from clay pebble media.

Their research detailed that SPAD-502 estimations of chlorophyll substance were profoundly related to leaf, N substance in each of the person development stages of foundation, blooming, fruiting and following fruiting (Padilla et al., 2015).



**Figure 4.13. Chlorophyll Content in matured butterhead lettuce leaves.**

## CHAPTER 5

### CONCLUSIONS AND RECOMENDATIONS

#### 5.1 Conclusion

During the hydroponic NFT design planning for butterhead lettuce and cherry tomato, the 3” (7.62 cm) UPVC pipe diameter was put into thought and created with a length of 150 cm each for 3 media, these channels were related utilizing a 90 degree elbow connection with net pot spacing of 0.15 m on each manifold, and 80 litre guppy tank for the capacity to hold the fertilizer nutrient A&B and water that must be absorbed by the plants, running through the channels with the aid of a submersible pump in a recirculating manner. Wooden structure was made to serve as base support for this NFT system with head height of 0.6 m from the ground and a distance of 1.4 m supporting the channels weight with liquid supplements. In addition, a net confirmation was created through wooden support for the systems with height of 0.63 m and 1.8 m to avoid direct sunshine penetration and unpleasant crawly ambushes or creepy crawly assault such as insects from attacking the plants.

The calculated variables for the NFT framework, the area attained was  $4.560e-3 \text{ m}^2$ , perimeter was 0.0785 m, hydraulic radius was 0.0581 m, velocity was 0.431 m/min, and hence, the attained flowrate was 117.9 L/hr.

Through the calculation for the suitable pump size for the framework or power transmitted to the liquid by the pump in watt, with determined flowrate (Q) of  $3.275e-5 \text{ m}^3/\text{s}$ , given thickness of the fluid ( $\rho$ ) to be  $1000 \text{ kg}/\text{m}^3$ , determined piezometric height of water (H) of 0.6 m, and putting into thought the normal concentrated of gravity which is 9.81, in this way, the calculated pump size/power (P) for the framework was 0.193 watt.

The butterhead lettuce fertilizer supplement A&B week after week addition, anticipated at 600 ml meaning addition of 86 ml per day of fertilizer nutrient A&B. Whereas, for the cherry tomato supplement A&B week by week addition, expected at 2100 ml meaning 300 ml daily addition of fertilizer A&B.

Thus, pH level will vary concurring to diverse plant necessity, in spite of the fact that in broad-spectrum numerous plants crave a somewhat corrosive developing environment, for butterhead lettuce it lean toward a pH run of 5.5 - 6.5 and EC range of 0.8 - 2.0 mS/m.

The first commonly pH utilized consistent methodology for situating sharpness, and it goes from 0 - 14, with low numbers being the first acidic and high numbers being the smallest acidic. The recommended pH for vegetables such tomatoes ranges from 5.5 - 6.5 whereas for a culminate building up, the overhaul course of movement for tomato cherry plants need to run an EC of 2.0 - 5.0 mS/m.

Through the One-way ANOVA, Mean comparison and SPSS plant tallness varieties within the three diverse butterhead lettuce media (perlite, clay pebbles and coco fiber) and the modification based on Post Hoc Numerous DMRT Multiple Comparison utilizing Duncan test run at significant level of 0.05. 9 Consonant Mean Test Estimate was utilized for each media totaling 27 test estimate for the 3 media. From the result, illustrate between groups and within groups appeared a significance contrast with a sig. of 0.004 meaning that ( $p < 0.05$ ). Post Hoc Tests Homogeneous Subsets tallness comparison utilizing Duncan shows that perlite media shifts altogether from the clay pebble and coco fiber media which appeared no significance between them.

Using the One-way ANOVA, Mean comparison and SPSS plant height variations within the 3 unmistakable cherry tomato media (perlite, clay stones and coco fiber)

and the alter based on Post Hoc Numerous Comparison utilizing Duncan test run at significant level of 0.05. 9 Consonant Mean Test Estimate was utilized for each media totaling 27 test for the 3 media. Outline between groups and within groups are not noteworthy which signify a sig. of 0.472 meaning that ( $p > 0.05$ ). Post Hoc Tests Homogeneous Subsets tallness comparison utilizing Duncan test appears that perlite, clay pebble and coco fiber media which showed up no significance or centrality between them.

Weight variations between the 3 media (coco fiber, clay pebbles and perlite) were demonstrated through the harvested cherry tomato fruits from the 27 samples, 9 samples from each media. From the weight analysis, clay pebble recorded the highest fruits weight and its stem in the net pots can withstand fruits weight up to 173.6g, also, it yielded more fruits and recorded greater weights, followed by perlite media and the least was recorded by the coco fiber media with lowest stem holding capacity fruits weight of 36.5g.

## **5.2 Recommendations**

1. From the 3 media (perlite, clay pebbles and coco fiber) of the NFT system for butterhead lettuce, it was demonstrated that butterhead lettuce did very well in the clay pebble and coco fiber media and poorly in the perlite media. Therefore, clay pebble and coco fiber media are well recommended while perlite media is not recommended as a result it welcomes algae formation and the perlite particles escapes the net pot holes to the nutrient and water tank which can cause blockage and poor pump transmission and poor support system to the plants.
2. The design inception, 15 cm net pot spacing was initially recommended for both butterhead lettuce and cherry tomato on the NFT system 3'' UPVC pipe

manifolds. It has been demonstrated that the initial recommended net pot spacing was not enough due to the mass elongation and expansion of the butterhead lettuce leaves and cherry tomato branches. Thus, it is now recommended that a minimum net pot spacing of 20 cm should be incorporated and abided by for greater efficiency and higher yield.

3. The height distance used in this NFT system for net protection or awning for cherry tomato was 1.8 m. It has been demonstrated that 1.8 m could not accommodate fully the progressing elongation of the cherry tomato stems and branches in the proposed NFT system. Moreover, it is now recommended that a minimum height distance of 2.5 m should be used for maximum efficiency, higher yield and complete overall protection. Finally, a proper and firm support base structure system either from wood or steel should be provided to support all the weights of the entire system and withstand the wind variations.

## References

- Andaluz, V. H., Tovar, A. Y., Bedon, K. D., Ortiz, J. S., & Pruna, E. (2016). *Automatic control of drip irrigation on hydroponic agriculture: Daniela tomato production*. Paper presented at the 2016 IEEE International Conference on Automatica, ICA-ACCA 2016.
- Crisnapati, P. N., Wardana, I. N. K., Aryanto, I. K. A. A., & Hermawan, A. (2017). *Hommons: Hydroponic management and monitoring system for an IOT based NFT farm using web technology*. Paper presented at the 2017 5th International Conference on Cyber and IT Service Management, CITSM 2017.
- Eridani, D., Wardhani, O., & Widiyanto, E. D. (2018). *Designing and implementing the arduino-based nutrition feeding automation system of a prototype scaled nutrient film technique (NFT) hydroponics using total dissolved solids (TDS) sensor*. Paper presented at the Proceedings - 2017 4th International Conference on Information Technology, Computer, and Electrical Engineering, ICITACEE 2017.
- Lenord Melvix, J. S. M., & Sridevi, C. (2014). *Design of efficient hydroponic nutrient solution control system using soft computing based solution grading*. Paper presented at the 2014 International Conference on Computation of Power, Energy, Information and Communication, ICCPEIC 2014.
- Limantara, L., Dettling, M., Indrawati, R., Indriatmoko, & Brotosudarmo, T. H. P. (2015). Analysis on the Chlorophyll Content of Commercial Green Leafy Vegetables. *Procedia Chemistry*, 14, 225-231. doi:https://doi.org/10.1016/j.proche.2015.03.032
- Padilla, F. M., Peña-Fleitas, M. T., Gallardo, M., & Thompson, R. B. (2015). Threshold values of canopy reflectance indices and chlorophyll meter readings for optimal nitrogen nutrition of tomato. *Annals of Applied Biology*, 166(2), 271-285. doi:10.1111/aab.12181
- Saaïd, M. F., Sanuddin, A., Ali, M., & Yassin, M. S. A. I. M. (2015). *Automated pH controller system for hydroponic cultivation*. Paper presented at the ISCAIE 2015 - 2015 IEEE Symposium on Computer Applications and Industrial Electronics.
- Saaïd, M. F., Yahya, N. A. M., Noor, M. Z. H., & Ali, M. S. A. M. (2013). *A development of an automatic microcontroller system for Deep Water Culture (DWC)*. Paper presented at the Proceedings - 2013 IEEE 9th International Colloquium on Signal Processing and its Applications, CSPA 2013.
- Sánchez-Del Castillo, F., Moreno-Pérez, E. d. C., Pineda-Pineda, J., Osuna, J. M., Rodríguez-Pérez, J. E., & Osuna-Encino, T. (2014). Hydroponic tomato (*Solanum lycopersicum* L.) production with and without recirculation of nutrient solution. *Agrociencia*, 48(2), 185-197.
- Sihombing, P., Karina, N. A., Tarigan, J. T., & Syarif, M. I. (2018). *Automated hydroponics nutrition plants systems using arduino uno microcontroller based on android*. Paper presented at the Journal of Physics: Conference Series.
- Siregar, B., Efendi, S., Pranoto, H., Ginting, R., Andayani, U., & Fahmi, F. (2018). *Remote monitoring system for hydroponic planting media*. Paper presented at the 2017 International Conference on ICT for Smart Society, ICISS 2017.
- Umamaheswari, S., Preethi, A., Pravin, E., & Dhanusha, R. (2017). *Integrating scheduled hydroponic system*. Paper presented at the 2016 IEEE International Conference on Advances in Computer Applications, ICACA 2016.
- Velazquez, L. A., Hernandez, M. A., Leon, M., Dominguez, R. B., & Gutierrez, J. M. (2013). *First advances on the development of a hydroponic system for cherry tomato culture*. Paper presented at the 2013 10th International Conference on Electrical Engineering, Computing Science and Automatic Control, CCE 2013.
- Yolanda, D., Hindersah, H., Hadiatna, F., & Triawan, M. A. (2017). *Implementation of real-time fuzzy logic control for NFT-based hydroponic system on Internet of Things environment*. Paper presented at the Proceedings of the 2016 6th International Conference on System Engineering and Technology, ICSET 2016.

## APPENDICES

### Appendix I: Determination of suitable pump size through the flowrate.

Flowrate, Q, Velocity, V, Manning Roughness, n: = 0.011 (Engineering ToolBox, 2004). Channel Slope, S (m/m) = 0.001, Area, A, Constant, K: = 1 & Perimeter, P (m), Hydraulic radius (cross-sectional area/wetted perimeter) = R (m).

$$A = \pi r^2$$

$$P = \frac{1}{2} \pi r^2 + d$$

$$R = A/P$$

$$V = \frac{k}{n} R^2 S^1$$

Therefore, Q = AV

If 1" = 0.0254m

Given the UPVC pipe size equals 3" = 0.0762m which is the diameter (d), and the radius (r) equals to 0.0381m, Manning Roughness, n: = 0.011, Channel Slope, S (m/m) = 0.001, Area, A, Constant, K: = 1 & Perimeter, P (m), Hydraulic radius (cross-sectional area/wetted perimeter) = R, Velocity, V (m) and find the flowrate (Q)?

Solutions:

$$A = \pi r^2$$

$$P = \frac{1}{2} \pi r^2 + d$$

$$= \pi (0.0381)^2$$

$$= \frac{1}{2} \pi (0.0381)^2 + 0.0762$$

$$A = 4.560 \times 10^{-3} \text{ m}^2$$

$$P = 0.0785 \text{ m}$$

$$R = A/P$$

$$V = \frac{k}{n} R^2 S^1$$

$$= 4.560 \times 10^{-3} \text{ m}^2 / 0.0785 \text{ m}$$

$$= \frac{1}{0.011} (0.0581)^2 (0.001)^1$$

$$R = 0.0581 \text{ m}$$

$$V = 0.431 \text{ m/min}$$

$$\text{Or } V = 7.183 \times 10^{-3} \text{ m/sec}$$

$$\begin{aligned}
 Q &= AV \\
 &= 4.560 \times 10^{-3} \text{ m}^2 \times 0.431 \text{ m/min} \\
 &= 1.965 \times 10^{-3} \text{ m}^3/\text{min} \\
 &= 3.275 \times 10^{-5} \text{ m}^3/\text{sec} \\
 &= 1.965 \text{ L/min}
 \end{aligned}$$

**Thus, the Flowrate, Q = 117.9 L/hr.**

Determination of suitable pump size for the system or Power transmitted to the fluid by the pump in Watt (P), with determined flowrate (Q) equal to  $3.275 \times 10^{-5} \text{ m}^3/\text{s}$  from the previous result in 4.1.1, given density of the liquid ( $\rho$ ) of  $1000 \text{ kg/m}^3$ , determined piezometric height of water (H) of 0.6 meters from Fig: 4.1.1, and putting into consideration the average intensity of gravity which equal to 9.81.

Solution

$$\begin{aligned}
 \text{Given formula; } P &= Q\rho H 9.81 \\
 &= 3.275 \times 10^{-5} \times 1000 \times 0.6 \times 9.81
 \end{aligned}$$

**Therefore, P = 0.193 Watt**